



Model 8700

Bottom Guided Pressure/Vacuum Relief Vent

OBJECTIVE

The Model 8700 emergency pressure/vacuum vents provide emergency pressure and vacuum relief beyond that furnished by the normal pressure vent for atmospheric and low pressure tanks, as well as providing a convenient access for tank cleaning, inspection and repair. Emergency relief valves provide relief from excessive internal pressure which may be caused by an abnormal condition, such as ruptured internal heating coils or an external fire. The vacuum relief allows the intake of air necessary to maintain the tank pressure within the permissible vacuum limit to avoid damage to the tank.

TECHNIQUE

The emergency vent pallet provides an effective vapor-tight seal when the tank is not under emergency conditions. If the tank outbreathing requirements exceeds the capability of the normal pressure relief vent, under emergency conditions, the pallet will raise to allow vapor to escape, preventing damage to the tank due to excess pressure. The emergency vent pallet is bottom guided so that when the excess pressure is relieved the pallet will reseal to again provide a vapor-tight seal.

CONSTRUCTION

The aluminum unit has an aluminum body with an aluminum seat, pallet and weather hood. The 304 stainless steel unit has a 304 stainless steel body and can be assembled with an aluminum pallet and weatherhood, a steel pallet and a steel weatherhood or a stainless steel pallet and a steel weatherhood. The 316 stainless steel unit is all stainless steel.

SPECIAL FEATURES

Easy Inspection and Maintenance: The Model 8700 vent is a rugged design and made to last. It is light weight for easy handling, inspection and maintenance. The easy removal of the weather hood allows unobstructed access to the tank for tank entry, inspection, and repairs.

Maintains Accurate Settings. Minimum pressure setting for Aluminum to 1.5 oz/in². Minimum pressure setting for Carbon Steel and Stainless Steel to 2.39 oz/in². Maximum pressure setting for Aluminum to 1 psig. The minimum vacuum setting available is 0.2 oz/in². and the maximum vacuum setting is 4 oz/in².

Air Cushion Pallet Design: Standard diaphragm material is FEP TFE. The FEP TFE diaphragm, the thickness of which is based on the vent size and the customer specified set point, forms around the seat to provide a tight seal due to the air cushion pallet design. Also available in FKM, EPDM and Buna-N.

Low-Leak Design: All units are tested to Valve Concepts, Inc. high standard for low leakage and set point accuracy prior to shipment. A certified test certificate is included with each vent verifying the set point accuracy and the seat leakage meets or exceeds API Standard 2000.

Available in Sizes. 16", 18", 20" and 24". Flanged to mate with standard ASME 150 # and API 650 bolting specifications. Other drilling patterns available on special request.

MATERIALS OF CONSTRUCTION		
Series	Body	Pallet
8700A	Aluminum	Aluminum
8700CS	304 SST	Aluminum, Steel or SST
8700SST	316 SST	316 SST

Алматы (7273)495-231
Ангарск (3955)60-70-56
Архангельск (8182)63-90-72
Астрахань (8512)99-46-04
Барнаул (3852)73-04-60
Белгород (4722)40-23-64
Благовещенск (4162)22-76-07
Брянск (4832)59-03-52
Владивосток (423)249-28-31
Владикавказ (8672)29-90-48
Владимир (4922)49-43-18
Волгоград (844)278-03-48
Вологда (8172)26-41-59
Воронеж (473)204-51-73
Екатеринбург (343)384-55-89

Иваново (4932)77-34-06
Ижевск (3412)26-03-58
Иркутск (395)279-98-46
Казань (843)206-01-48
Калининград (4012)72-03-81
Калуга (4842)92-23-67
Кемерово (3842)65-04-62
Киров (8332)68-02-04
Коломна (4966)23-41-49
Кострома (4942)77-07-48
Краснодар (861)203-40-90
Красноярск (391)204-63-61
Курск (4712)77-13-04
Курган (3522)50-90-47
Липецк (4742)52-20-81

Магнитогорск (3519)55-03-13
Москва (495)268-04-70
Мурманск (8152)59-64-93
Набережные Челны (8552)20-53-41
Нижний Новгород (831)429-08-12
Новокузнецк (3843)20-46-81
Ноябрьск (3496)41-32-12
Новосибирск (383)227-86-73
Омск (3812)21-46-40
Орел (4862)44-53-42
Оренбург (3532)37-68-04
Пenza (8412)22-31-16
Петрозаводск (8142)55-98-37
Псков (8112)59-10-37
Пермь (342)205-81-47

Ростов-на-Дону (863)308-18-15
Рязань (4912)46-61-64
Самара (846)206-03-16
Санкт-Петербург (812)309-46-40
Саратов (845)249-38-78
Севастополь (8692)22-31-93
Саранск (8342)22-96-24
Симферополь (3652)67-13-56
Смоленск (4812)29-41-54
Сочи (862)225-72-31
Ставрополь (8652)20-65-13
Сургут (3462)77-98-35
Сыктывкар (8212)25-95-17
Тамбов (4752)50-40-97
Тверь (4822)63-31-35

Тольятти (8482)63-91-07
Томск (3822)98-41-53
Тула (4872)33-79-87
Тюмень (3452)66-21-18
Ульяновск (8422)24-23-59
Улан-Удэ (3012)59-97-51
Уфа (347)229-48-12
Хабаровск (4212)92-98-04
Чебоксары (8352)28-53-07
Челябинск (351)202-03-61
Череповец (8202)49-02-64
Чита (3022)38-34-83
Якутск (4112)23-90-97
Ярославль (4852)69-52-93

Россия +7(495)268-04-70

Казахстан +7(7172)727-132

Киргизия +996(312)96-26-47

STANDARD/GENERAL SPECIFICATIONS

**Diaphragm
Temperature
Limits:**

FEP-TFE:
-400° to 400° F (-240° to 204°C)
Fluorocarbon Elastomer – (FKM):
0° to 400° F (0° to 204°C)
Buna-N (Nitrile-NBR):
-30° to 200° F (-34° to 93°C)
EPDM (Ethylenepropylene):
-40° to 225° F (-40° to 107°C)

Painting:

Standard: All non-corrosion resistant portions to be painted with corrosion resistant epoxy paint per Cashco Spec #S-1777.

**Spring
Ranges:**

TABLE 6 - VACUUM RANGE SPRING	
Range oz/in²	mbar
0.2 - 1	0.86 - 4.31
> 1 - 2	4.31 - 8.61
> 2 - 3	8.61 - 12.93
> 3 - 4	12.93 - 17.24

The contents of this publication are presented for informational purposes only, and while every effort has been made to ensure their accuracy, they are not to be construed as warranties or guarantees, express or implied, regarding the products or services described herein or their use or applicability. We reserve the right to modify or improve the designs or specifications of such product at any time without notice. Cashco, Inc. does not assume responsibility for the selection, use or maintenance of any product. Responsibility for proper selection, use and maintenance of any Cashco, Inc. product remains solely with the purchaser.

DIMENSIONS

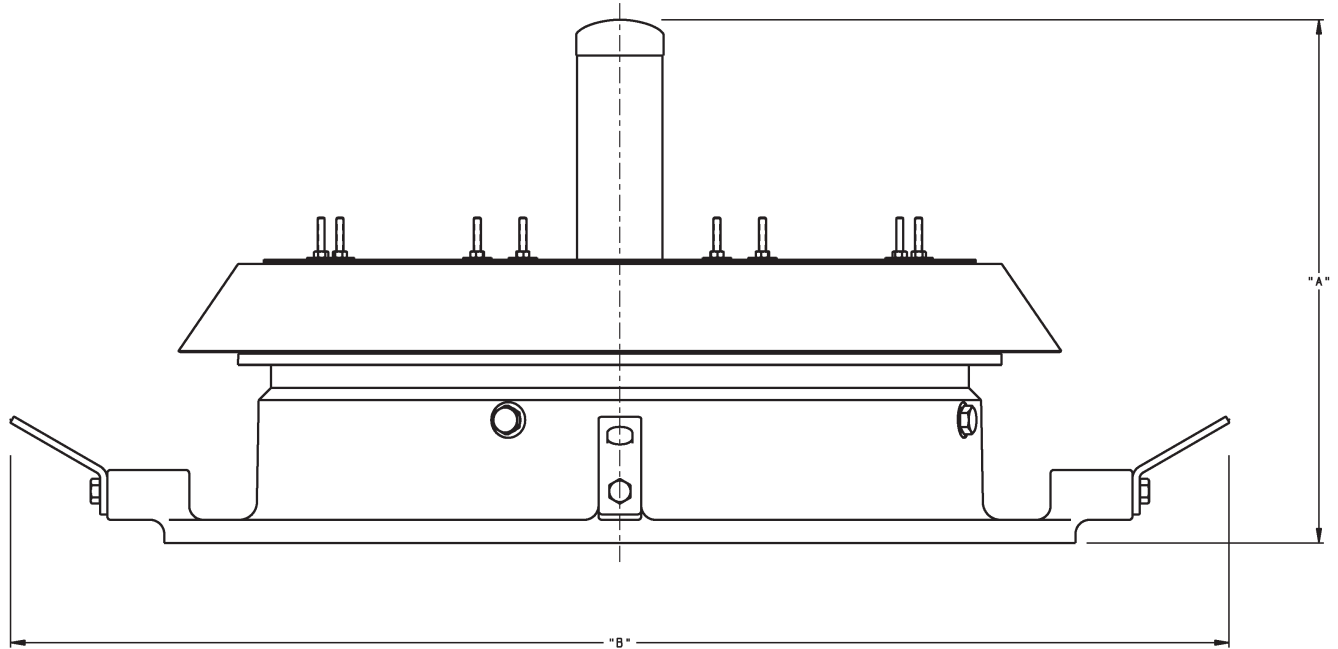

DIMENSIONS - in			Weight - lbs *		
Size	A	B	Alum	SST/ Alum	SST
16"	18.4	31.78	72	163	186
18"	18.3	33.25	79	177	206
20"	18.3	37.78	82	178	207
24"	18.3	42.78	101	238	259

DIMENSIONS - mm			Weight - kgs *		
Size	A	B	Alum	SST/ Alum	SST
DN400	468	807	33	74	85
DN450	465	845	36	80	93
DN500	465	960	37	81	94
DN600	465	1087	46	108	118

* Does not include loading weights

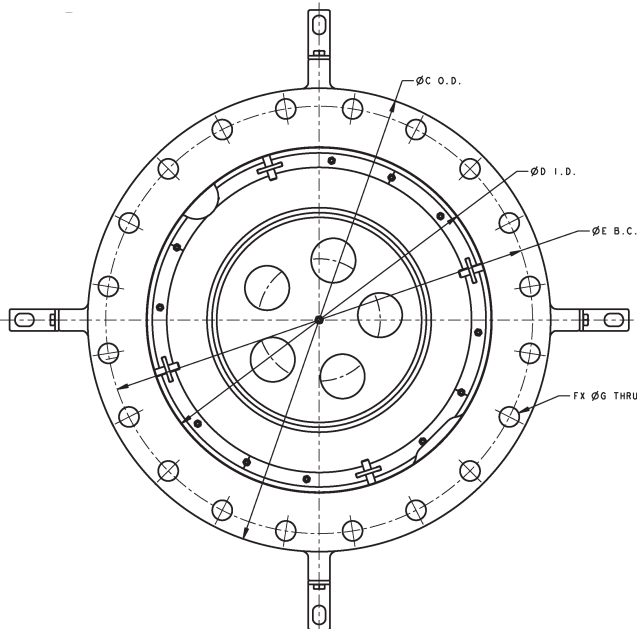

DIMENSIONS - in					
150# (PN16) FF Flange & Bolting Specification					
SIZE	$\varnothing C \text{ O.D.}$	$\varnothing D \text{ I.D.}$	$\varnothing E \text{ B.C.}$	$F_x \text{ (Qty)}$	$\varnothing G$
(ASME) 16"	23.5	15.82	21.25	16	1.12
(ASME) 18"	25	17.82	22.75	16	1.25
(ASME) 20"	27.5	19.82	25	20	1.25
(ASME) 24"	32	23.87	29.5	20	1.38
(API) 20"	26	19.82	23.5	16	0.75
(API) 24"	30	23.87	27.5	20	0.75
(DIN) DN400	23	17	20.67	16	1.12
(DIN) DN450	25.25	19	23.03	20	1.12
(DIN) DN500	28.18	20.62	25.59	20	1.25
(DIN) DN600	33	24.62	30.31	20	1.43

8700 Series PRODUCT CODE 10/12/20

Last 6 Characters reserved for SPQ drawing numbers assigned by Cashco Inc.
(Format as - # # # # #)

87 POS 3 POS 4 POS 5 **A** POS 7 **S** **0** POS 10 **0** **0** **0** **0** **0** **0** **0** **0**

POSITION 3 - FF FLANGE BOLTING	
To Specification	CODE
ASME 150#	0
API 650 *	P
DIN PN16	D

* Not Available Sizes 16" or 18"

POSITION 4- SIZE		
INCH	(DN)	CODE
16"	(400)	F
18"	(450)	C
20"	(500)	D
24"	(600)	E

POSITION 5 - BODY / PALLET / WEATHER HOOD MATERIALS	
MATERIAL	CODE
Alum / Alum / Alum	A
304 SST / Alum / Alum	B
304 SST / CS / CS	C
304 SST / 316 SST / CS	D
316 SST / 316 SST / 304 SST	S

POSITION 7 - DIAPHRAGM MATERIALS	
Diaphragm Material	CODE
FEP TFE (Std)	A
Buna-N	B
EPDM	D
FKM	F

POSITION 10 - VACUUM RANGE SPRING		
Range oz/in ²	Millibar	CODE
0.2 - 1	0.86 - 4.31	1
> 1 - 2	4.31 - 8.61	2
> 2 - 3	8.61 - 12.93	3
> 3 - 4	12.93 - 17.24	4

Алматы (7273)495-231
Ангарск (3955)60-70-56
Архангельск (8182)63-90-72
Астрахань (8512)99-46-04
Барнаул (3852)73-04-60
Белгород (4722)40-23-64
Благовещенск (4162)22-76-07
Брянск (4832)59-03-52
Владивосток (423)249-28-31
Владикавказ (8672)28-90-48
Владимир (4922)49-43-18
Волгоград (844)278-03-48
Вологда (8172)26-41-59
Воронеж (473)204-51-73
Екатеринбург (343)384-55-89

Иваново (4932)77-34-06
Ижевск (3412)26-03-58
Иркутск (395)279-98-46
Казань (843)206-01-48
Калининград (4012)72-03-81
Калуга (4842)92-23-67
Кемерово (3842)65-04-62
Киров (8332)68-02-04
Коломна (4966)23-41-49
Кострома (4942)77-07-48
Краснодар (861)203-40-90
Красноярск (391)204-63-61
Курск (4712)77-13-04
Курган (3522)50-90-47
Липецк (4742)52-20-81

Магнитогорск (3519)55-03-13
Москва (495)268-04-70
Мурманск (8152)59-64-93
Набережные Челны (8552)20-53-41
Нижний Новгород (831)429-08-12
Новокузнецк (3843)20-46-81
Ноябрьск (3496)41-32-12
Новосибирск (383)227-86-73
Омск (3812)21-46-40
Орел (4862)44-53-42
Оренбург (3532)37-68-04
Пенза (8412)22-31-16
Петрозаводск (8142)55-98-37
Псков (8112)59-10-37
Пермь (342)205-81-47

Ростов-на-Дону (863)308-18-15
Рязань (4912)46-61-64
Самара (846)206-03-16
Санкт-Петербург (812)309-46-40
Саратов (845)249-38-78
Севастополь (8692)22-31-93
Саранск (8342)22-96-24
Симферополь (3652)67-13-56
Смоленск (4812)29-41-54
Сочи (862)225-72-31
Ставрополь (8652)20-65-13
Сургут (3462)77-98-35
Сыктывкар (8212)25-95-17
Тамбов (4752)50-40-97
Тверь (4822)63-31-35

Тольятти (8482)63-91-07
Томск (3822)98-41-53
Тула (4872)33-79-87
Тюмень (3452)66-21-18
Ульяновск (8422)24-23-59
Улан-Удэ (3012)59-97-51
Уфа (347)229-48-12
Хабаровск (4212)92-98-04
Чебоксары (8352)28-53-07
Челябинск (351)202-03-61
Череповец (8202)49-02-64
Чита (3022)38-34-83
Якутск (4112)23-90-97
Ярославль (4852)69-52-93

Россия +7(495)268-04-70

Казахстан +7(7172)727-132

Киргизия +996(312)96-26-47

<https://cashco.nt-rt.ru/> || coc@nt-rt.ru