



ISO Registered Company

PTR-1-TB

01-23



MODEL PTR-1

PRESSURE TEMPERATURE REGULATOR

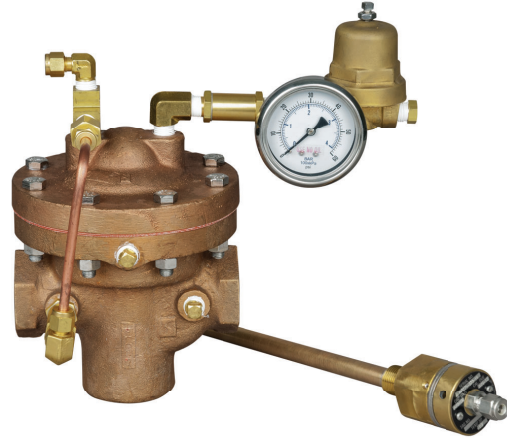

MODEL PTR-1

OVERVIEW

Model PTR-1 is high performance, pressure loaded diaphragm-type, flow-to-open pressure reducing regulator. Design includes an internal pressure balancing piston-cylinder that provides high flow capacity and high pressure drop capability. Performance meets or exceeds that of competitive pressure loaded or pilot-operated designs. A back pressure regulator or "unloader" is piped to the top of the dome and is "set" to control the outlet pressure of the pressure reducing regulator. In addition, a low temperature probe (pneumatic controller) with an integral, rigid insertion bulb and invar rod is installed up-stream of the Model PTR-1. When the exposed outer sheath sense a change in the process temperature below the minimum temperature set point of the probe, it vents loading pressure from the dome of the regulator and allows it to close.

FEATURES

- Versatile:** Two basic materials and multiple trim material combinations to select from.
- Tight Shutoff:** Multiple composition materials provide Class IV and VI inboard leakage rates. Designed as a soft-seated valve.
- Capacity:** Highest in the industry. Allows smaller body sizes than competitors in a majority of applications.
- Droop:** Highly accurate outlet pressure control, due to absence of range spring in design, provides almost zero "droop effect".
- Trim Design:** FTO and pressure balancing for higher inlet pressure. Results in unmatched sensitivity and stability. Internals are cage-contained within easily removable quick change trim.
- Rangeability:** Basic valve gives outstanding rangeability due to close tolerances, balanced trim, and broad range of elastomeric and metallic diaphragms and soft seats. Can be as high as 2000:1.
- Heavy-Duty Guiding:** Both top and bottom guided to maintain stability and increased diaphragm life.
- Failure Position:** Fails closed on loss of loading pressure.



LINE SIZES AVAILABLE

1/2" (DN15), 3/4" (DN20), 1" (DN25), 1-1/4" (DN32), 1-1/2" (DN40), 2" (DN50), 2-1/2" (DN65), 3" (DN80), 4" (DN100)



END CONNECTIONS

NPT, FLANGED, BSPT



COMMON APPLICATIONS

GASEOUS SERVICE, ATMOSPHERIC INDUSTRIAL GASES



DESIGN PRESSURE

MAX. OPERATING: 525 psig (36.2 Barg)
OUTLET: 2.0-400 psig (0.13-27.6 Barg)

Алматы (7273)495-231
Ангарск (3955)60-70-56
Архангельск (8182)63-90-72
Астрахань (8512)99-46-04
Барнаул (3852)73-04-60
Белгород (4722)40-23-64
Благовещенск (4162)22-76-07
Брянск (4832)59-03-52
Владивосток (423)249-28-31
Владикавказ (8672)28-90-48
Владимир (4922)49-43-18
Волгоград (844)278-03-48
Вологда (8172)26-41-59
Воронеж (473)204-51-73
Екатеринбург (343)384-55-89

Иваново (4932)77-34-06
Ижевск (3412)26-03-58
Иркутск (395)279-98-46
Казань (843)206-01-48
Калининград (4012)72-03-81
Калуга (4842)92-23-67
Кемерово (3842)65-04-62
Киров (8332)68-02-04
Коломна (4966)23-41-49
Кострома (4942)77-07-48
Краснодар (861)203-40-90
Красноярск (391)204-63-61
Курск (4712)77-13-04
Курган (3522)50-90-47
Липецк (4742)52-20-81

Магнитогорск (3519)55-03-13
Москва (495)268-04-70
Мурманск (8152)59-64-93
Набережные Челны (8552)20-53-41
Нижегород (831)429-08-12
Новокузнецк (3843)20-46-81
Ноябрьск (3496)41-32-12
Новосибирск (383)227-86-73
Омск (3812)21-46-40
Орел (4862)44-53-42
Оренбург (3532)37-68-04
Пенза (8412)22-31-16
Петрозаводск (8142)55-98-37
Псков (8112)59-10-37
Пермь (342)205-81-47

Ростов-на-Дону (863)308-18-15
Рязань (4912)46-61-64
Самара (846)206-03-16
Санкт-Петербург (812)309-46-40
Саратов (845)249-38-78
Севастополь (8692)22-31-93
Саранск (8342)22-96-24
Симферополь (3652)67-13-56
Смоленск (4812)29-41-54
Сочи (862)225-72-31
Ставрополь (8652)20-65-13
Сургут (3462)77-98-35
Сыктывкар (8212)25-95-17
Тамбов (4752)50-40-97
Тверь (4822)63-31-35

Тольятти (8482)63-91-07
Томск (3822)98-41-53
Тула (4872)33-79-87
Тюмень (3452)66-21-18
Ульяновск (8422)24-23-59
Улан-Уда (3012)59-97-51
Уфа (347)229-48-12
Хабаровск (4212)92-98-04
Чебоксары (8352)28-53-07
Челябинск (351)202-03-61
Череповец (8202)49-02-64
Чита (3022)38-34-83
Якутск (4112)23-90-97
Ярославль (4852)69-52-93

Россия +7(495)268-04-70

Казахстан +7(7172)727-132

Киргизия +996(312)96-26-47

STANDARD / GENERAL SPECIFICATIONS

Body / Cover Dome Materials

BRZ/BRZ SST/SST
BRZ = Bronze SST = Stainless Steel

Body Sizes

1/2", 3/4", 1", 1-1/4", 1-1/2", 2", 2-1/2", 3", 4".
(DN15, 20, 25, 32, 40, 50, 65, 80, 100)

End Connections

Standard: Female NPT.
ASME Flanged: 150#, 300#, 600#;
DIN Flanged: PN16, PN25, PN40;
(Integral Flanged Body unless listed under Opt.-30)
Opt-31: British Standard Pipe Threads.

Max. Useable Cv

See TABLE 7 for Wide Open Cv Limits.

METRIC CONVERSION FACTOR: $Cv / 1.16 = kv$

Body Size		Comp. Cv	Body Size		Comp. Cv
in	(DN)		in	(DN)	
1/2"	(15)	3.6	2"	(50)	54
3/4"	(20)	7.2	2-1/2"	(65)	81
1"	(25)	13.5	3"	(80)	108
1-1/4"	(32)	20.7	4"	(100)	198
1-1/2"	(40)	27.0			

Max Operating Pressure

525 psig (36.2 Barg).

See TABLES 1B through 1F for design P vs. T limits.

Outlet Pressure Range

2.0 - 400 psig (0.13 - 27.6 Barg).

Multiple springs - ranges dependent on selection of the unloader. See Position 13 on the coder.

Function of diaphragm material. See TABLE 6.

Pressure Drop Limits

5–355 psid (.34 – 24.5 Bard)

Function of service fluid, base trim material, diaphragm and dynamic seal design. See TABLES -2, -3, -4 & -6.

Temperature Range

-325° to +400°F (-198° to +204° C)

Limited by body/cover dome/diaphragm material combinations, and by elastomeric seat, static seal, dynamic seal – materials. See TABLES 1B, 1E, 1F and 5.

Inboard Leakage Rate

See TABLE 10

Lower Piston Spring

No lower piston spring; $P_2 = P_{Load}$.
Lower piston spring required; $P_2 < P_{Load}$.
See TABLE-9 for available spring ranges.

NOTE: Use a lower piston spring with the following applications:

1. When decaying inlet may reach 0 psig.

Optional Constructions

Opt-30: Weld-on Flanges Opt-85: Extra Set Pressure
Opt-31: BSP End Conns. Taps

Unloader Specifications

Self contained back pressure regulator. 1/4" Size, NPT connections. Available with Bronze or SST body and spring chamber. S2 Trim - SST metal seat and diaphragm. 1/4" NPT bug screen vent in outlet connection. Range springs from 2 to 400 psig. (See Position 13 on the coder.) See Position 14 on coder for selection of materials for connecting tubing, orifice and filters.

Low Temperature Probe Specification

The Probe is a low temperature shutoff device with an integral, rigid insertion bulb used to protect downstream piping systems and equipment from experiencing temperature excursions below desired minimum operating temperature due to equipment malfunction or customer overdraw of system capacity.

Bronze or SST thermal elements, encase an invar plunger for controlling temperature set points that range between -50°F to +50°F. Probe venting begins at 8°F above Temperature Set Point (TSP). "Full Venting " at TSP. Control head inlet pressure upwards to 600 psig. Standard insertion connection 1/2" NPT.

Specify Opt-64 for O-ring insertion seal, thermal well is not provided.

Customer to provide connecting tubing between the probe and the dome of the regulator at installation.

Use 1/4" tubing (ID of 0.180" or greater) when probe is installed within 18 feet of regulator.

Use 3/8" tubing (ID of 0.277" or greater) when probe is installed within 150 feet of regulator.

MATERIAL SPECIFICATIONS

Body

BRZ – ASTM B62, Alloy 83600,
SST – ASTM A351, Grade CF3M.

See TABLES 1B or 1E & 1F for material specs.

Cover Dome

BRZ – ASTM B62, Alloy 83600,
SST – ASTM A351, Grade CF3M

Metallic Trim *

Plug, Cage: 17-4PH SST, 316L SST,
 Nickel-Copper Alloy (Monel[†]),

PART	TRIM DESIGNATION		
	M	S	T
Plug	Monel †	316L SST	17-4 PH SST
Guide Bearing	Monel †	316L SST	17-4 PH SST
Cage	Monel †	316L SST	Monel †
Body Bushing	Monel †	Monel †	Monel †

Diaphragm *

FKM, FK.

Seat *

PolyAll, V-TFE, GF-TFE.

Static Seals (See Fig. F1) *

FKM, FK - o-ring
 SST/TFE (1/2"-2") (DN15-50) sizes,
 V-TFE (2-1/2"-4") (DN65-100) sizes.

Dynamic Seals (See Fig. F1) *

Type OR - FKM - o-ring seal.
Type UC – V-TFE u-cup seal w/ 316L SST energizer
Type CW – TFE cap seal with o-ring energizer
 (o-ring material same as static seal)
 and GF-TFE wiper backup seal.

STD. Cleaning - GOX.

Main unit, unloader and temperature probe cleaned, assembled and packaged per Cashco Spec #S-1134, suitable for Oxygen service. **NOTE: Design Pressure Rating shall not exceed 375 psig (25.8 Barg) when body/topworks material is SST and process medium is oxygen.**

Painting

Standard: All non-corrosion resistant portions to be painted with corrosion resistant epoxy paint per Cashco Spec #S-1606.

* See Product Coder for acceptable combinations.
 † Hastelloy[®], Monel[™] and Inconel[®] are registered trade names:
 Hastelloy[®] is a mark owned by Stelite Div., Cabot Corp.
 Monel[™] is a mark owned by International Nickel Co.
 Inconel[®] is a mark owned by International Nickel Co.

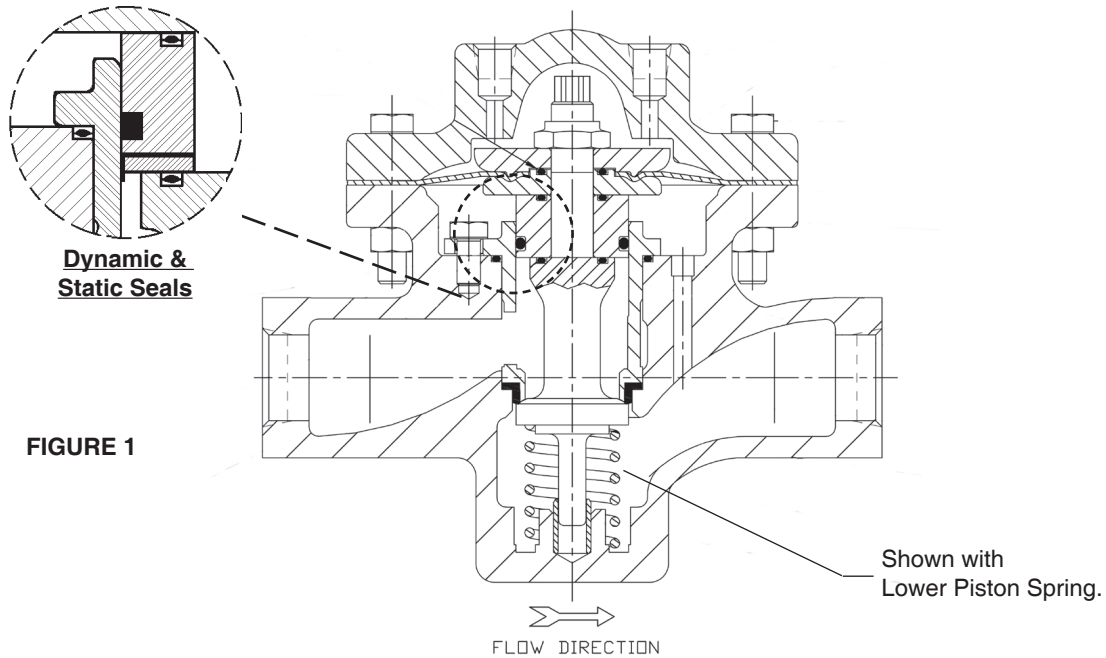

OPTION SPECIFICATIONS

OPT-30: WELD FLANGED CONNECTIONS. SST body materials only. 1/2" – 1-1/2" (DN15–40) body sizes only (no 1-1/4" (DN32) size). Weld-on flange of same general chemistry as body.

Weld-On Flanges		
Sizes	Body Material	ASME Pressure Class
1/2" - 3/4"	SST	150, 300, 600
1"	SST	600
Sizes	Body Material	ISO Pressure Class
DN15-50	SST	PN40 RF
DN65-100	SST	PN16, 25, 40 RF

NOTES: 1. The body P vs. T ratings are the limiting variables for flanged end connections, unless further restricted by ASME B16.5.
 2. No post-weld stress relieving performed.

OPT-31: BSP END CONNECTIONS. British Standard Pipe threads per ISO 7/1; used as an alternate to NPT ends. 1/2" – 2" (DN15–50) sizes only.

OPT-85: PRESSURE TAPS. Provides second set of inlet and outlet 1/4" (DN8) - FNPT taps with plugs (same basic material as body) on backside of body. Includes second external sensing port tap. See Figure F2 for details on tap location for both STD. and Opt -85.

TECHNICAL SPECIFICATIONS APPENDIX INDEX

<u>TABLE</u>	<u>TITLE</u>	<u>PAGE</u>
1B	BRZ – Press vs Temp vs End Conn Ratings	5
1E	SST – Press vs Temp vs End Conn Ratings – Design Inlet	6
1F	Design Outlet	6
2	Max Pressure Drop - Comp Seat	7
3	Max Pressure Drop - Dynamic Seal Design	7
4	Max Pressure Drop - Basic Trim Mat'ls	7
5	Temperature Limits – Elastomer Mat'ls	8
6	Max Diaphragm Rating	8
7	Reducer Max Capacity - Plug Wide Open	9
8	Pressure Loading System Tubing & Fitting Maximum Containment Pressure Process or Auxiliary Fluids	9
9	Reducer Lower Piston Spring range	9
10	Inboard Leakage Ratings	10
11	Reducer Recommended Velocity Limits	10
12	Max Recommended Noise Limits	10
13	Recommended Internal Materials - Gases	11
	Supplement - Chemical Resistance	11
14	ISR Effect	12
FIGURE		
F1	Dynamic/Static Seals	12
F2	Location of Body Taps	13

TABLE 1B
BRZ – BRONZE
BODY / TOPWORKS MATERIAL SPECIFICATIONS

DESIGN PRESSURE vs. TEMPERATURE vs. END CONNECTION RATINGS
(Per ASME B16.24 for Flanged and B16.15 for NPT Connections)

Material Specifications (Body / Topworks)		End Connection – Inlet & Outlet (Note 1)					
Description (Abbr.)	ASTM No.	Temperature °F	Working Pressure –psig				
			End Connection – Pressure Class				
			NPT	150# FF	300# FF		
BRZ/BRZ	B62, Alloy C83600/B62, Alloy C83600	-325° to +150° *	700 † / 500	225	500		
		175°	390	220	480		
		200°	385	210	465		
		225°	375	205	445		
		250°	365	195	425		
		300°	335	180	390		
		350°	300	165	350		
		400°	250	150	315		
		406°	250	150	315		
		Temperature °C		Working Pressure – Barg			
				End Connection – Pressure Class			
				NPT	150# FF	300# FF	
				-198° to +65° *	48.3 † / 34.5	15.5	34.5
				107°	25.8	14.0	30.8
				120°	25.1	13.5	29.5
				150°	23.0	12.4	26.8
				177°	20.4	11.3	24.0
				204°	17.8	10.3	21.4

† Use 700 psig (48.2 Barg) inlet / 500 psig (34.4 Barg) outlet at 150°F as maximum limits.

NOTE 1: Unless stated otherwise, design pressure is Maximum Allowable Working Pressure (MAWP) for Inlet and Outlet.

* See Minimum Temperature Ratings Table below.

DESIGN PRESSURE RATING
AT MIN. TEMPERATURE

Regulator Function	Material Specifications (Body / Topworks - Connections) Description (Abbr.)	Pressure at Min. Temperature
Pressure Reducing	BRZ/BRZ - NPT	Inlet - 475 psig CWP to -325°F (-198°C)
		Outlet - 475 psig CWP to -325°F (-198°C)
	SST/SST - NPT, BSP, and 600# Flgs	Inlet - 475 psig CWP to -425°F (-254°C)
		Outlet - 475 psig CWP to -425°F (-254°C)

Body Material Specifications

Cast Stainless Steel A351 Gr.CF3M or Stainless Steel Weldment A315 Gr. CF3M w/ forged flanges A182 Gr. F 316L

Topworks Material Specifications

Cast Stainless Steel A351 Gr.CF3M

DESIGN PRESSURE vs. TEMPERATURE vs END CONNECTION RATINGS (Per ASME B16.5 and B16.34) See NOTE 1

TABLE 1E				
DESIGN INLET PRESSURE				
in PSIG (BARG)				
DESIGN TEMP. RANGE: Deg F (Deg C) *	END CONNECTIONS			
	NPT, BSP	600#	150#	300#
-325 to +100 (-254 to +38)	1440 (99.3)	1440 (99.3)	275 (19.0)	720 (49.6)
-20 to +200 (-29 to +93)	1240 (86.1)	1240 (86.1)	235 (16.5)	620 (43.0)
-20 to +300 (-29 to +149)	1120 (77.1)	1120 (77.1)	215 (14.8)	560 (38.6)
-20 to +400 (-29 to +204)	1025 (70.9)	1025 (70.9)	195 (13.6)	515 (35.5)

* For Temperatures below -20°F - refer to page 5 for Design Pressure Rating at Min. Temperature.

TABLE 1F			
DESIGN OUTLET PRESSURE			
in PSIG (BARG)			
DESIGN TEMP. RANGE: Deg F (Deg C) *	END CONNECTIONS		
	NPT, BSP, 600#	150#	300#
-325 to +100 (-254 to +38)	625 (43.0)	275 (19.0)	625 (43.0)
-20 to +200 (-29 to +93)	620 (42.3)	235 (16.5)	620 (42.3)
-20 to +300 (-29 to +149)	560 (38.6)	215 (14.8)	560 (38.6)
-20 to +400 (-29 to +204)	515 (35.5)	195 (13.6)	515 (35.5)

* For Temperatures below -20°F - refer to page 5 for Design Pressure Rating at Min. Temperature.

NOTE 1: 300# Flanges are derated due to the bolting for these products.

**TABLE 2
MAXIMUM PRESSURE DROP FOR
COMPOSITION SEATS**

Body Size		Max. Pressure Drop - psid (Bard)					
		Seat Material					
in	(DN)	POLYALL		GF-TFE		V-TFE	
1/2" – 1"	(15-25)	750	(51.7)	1000	(68.9)	600	(41.3)
1-1/4" – 1-1/2"	(32-40)	600	(41.3)	900	(62.0)	600	(41.3)
2"	(50)	600	(41.3)	750	(51.7)	600	(41.3)
2-1/2" – 4"	(65-100)	600	(41.3)	750	(51.7)	450	(31.0)

**TABLE 3
MAXIMUM PRESSURE DROP FOR
DYNAMIC SEAL DESIGNS**

Body Size		Max. Pressure Drop - psid (Bard)					
		Dynamic Seal Design					
in	(DN)	"OR" – O-RING		"CW" – TFE CAP w/WIPER		"UC" - U-CUP	
1/2" – 1"	(15-25)	750	(51.7)	600	(41.3)	3000	(206.9)
1-1/4" – 1-1/2"	(32-40)	750	(51.7)	600	(41.3)	3000	(206.9)
2"	(50)	750	(51.7)	600	(41.3)	3000	(206.9)
2-1/2" – 4"	(65-100)	750	(51.7)	600	(41.3)	3000	(206.9)

**TABLE 4
MAXIMUM PRESSURE DROP FOR
BASIC TRIM MATERIAL**

Body Size		Max. Pressure Drop - psid (Bard)					
		Basic Trim Material					
in	(DN)	"S" – 316L SST		"M" – Monel		"T" – Hybrid *	
1/2" – 2"	(15-50)	800	(55.1)	1500	(103.4)	3000	(206.9)
2-1/2" – 4"	(65-100)	800	(55.1)	1500	(103.4)	3000	(206.9)

* 17-4PH SST plug, Monel cage.

**TABLE 5
TEMPERATURE LIMITS
FOR ELASTOMERIC MATERIALS**

Elastomer			T Maximum		T Minimum	
Seals	ID	Description	°F	(°C)	°F	(°C)
	Seats	PolyAll	Proprietary Polyurethane Derivative	225°	(107°)	-60°
GF-TFE		Glass-filled Polytetrafluorethylene	425°	(218°)	-325°	(-198°)
V-TFE		Virgin TFE	400°	(205°)	-325°	(-198°)
Diaphragms	FK	Fluorosilicone	350°	(177°)	-65°	(-54°)
	FKM	Fluorocarbon Elastomer	400°	(205°)	0°	(-17°)
	FKM+TFE	Fluorocarbon Elastomer + TFE	400°	(205°)	0°	(-17°)
Static Seals	FK	Fluorosilicone	350°	(177°)	-65°	(-54°)
	FKM	Fluorocarbon Elastomer	400°	(205°)	-20°	(-28°)
	SST/TFE	301/302 SST U-cup / TFE	400°	(205°)	-325°	(-198°)
Dynamic Seals	"CW" – FK/TFE	TFE Cap Seal, FK O-ring, GF-TFE Wiper	350°	(177°)	-40°	(-40°)
	"CW" – FKM/TFE	TFE Cap Seal, FKM O-ring, GF-TFE Wiper	400°	(205°)	-20°	(-28°)
	SST/TFE	301/302 SST U-cup / TFE	400°	(205°)	-325°	(-198°)

ABBREVIATIONS		
FK = Fluorosilicone	FKM = Fluorocarbon	GF-TFE = Glass-fill TFE
PA = PolyAll		V-TFE = Virgin TFE

**TABLE 6
MAXIMUM DIAPHRAGM RATING psig (Barg) ***

NOTE: The below ratings may be further "derated" by limitations through the Pressure Equipment Directive (2014/68/EU).

Diaphragm Material	BODY SIZE 1/2"-2" (DN15-50)	BODY SIZE 2-1/2"-4" (DN65-100)
	STD DIAPHRAGM CONSTRUCTION	STD DIAPHRAGM CONSTRUCTION
FKM, FKM+TFE, FK	700 (48.2)	550 (37.9)

* Maximum pressure setpoint of Pressure Safety Valve or Rupture disk should not exceed 1.5 times tabulated value to prevent irreversible diaphragm mechanical damage or rupture.

**TABLE 7
REDUCER MAXIMUM CAPACITY WITH PLUG WIDE-OPEN**

Body Size		Full Port Max Capacity	
in	(DN)	Cv	Kv
1/2"	(15)	4.0	3.4
3/4"	(20)	8.0	6.9
1"	(25)	15	13
1-1/4"	(32)	23	20
1-1/2"	(40)	30	26
2"	(50)	60	52
2-1/2"	(65)	90	78
3"	(80)	120	104
4"	(100)	220	190

NOTE: The above Cv factors may be used for sizing of safety relief valves or rupture discs.

**TABLE 8
PRESSURE LOADING SYSTEMS
MAXIMUM CONTAINMENT PRESSURE PROCESS OR AUXILIARY FLUIDS**

TUBE	FITTINGS	PRESSURE		TEMPERATURE	
		psig	(Barg)	°F	(°C)
CU*	BR	1400	(96.5)	-325 to +100	(-198 to +37.7)
		1140	(78.6)	200	(93.3)
		1100	(75.8)	300	(148.8)
		700	(48.2)	400	(204.4)
SST^	SST	3600	(248.2)	-325 to +400	(-198 to +204.4)

*1/4" O.D. X 0.030" Wall Thickness

^1/4" O.D. X 0.028" Wall Thickness

Application Notes:

1. Consult Factory for T1<0° F.
2. Use Heat Exchange "coils" when loading fluid (process, auxiliary) T1>140°F
3. Use Heat Exchange "coils" when T1<0°F

**TABLE 9
LOWER PISTON SPRING RANGES**

Lower Piston Spring Range psig	Application Notes
N/A	All Unloader Range Springs
1-2	Required when Unloader Range Spring is 2 - 30 psig
2-5	For Unloader Range Springs 10 - 360 psig

- NOTES:**
1. The 2-5 psig lower piston spring is –
 - most commonly selected,
 - recommended for GF-TFE and CTFE seats,
 - recommended for tighter shutoff; i.e. lowest inboard leakage.
 2. Lower spring material matches main metallic trim in corrosion resistance.

TABLE 10
INBOARD LEAKAGE RATINGS *
Per ANSI/FCI 70-2

Seat Material	Dynamic Seal	
	O-Ring	Dynamic Seals Except O-Ring
GF-TFE, and V-TFE	IV	IV
PolyAll	VI	IV
*Inboard leak rates are the composite leakage of the seat leakage + dynamic seal leakage, considered as a single inboard leakage value.		

TABLE 11
REDUCER RECOMMENDED VELOCITY LIMITS

Application Fluid	Valve		Valve Body Outlet		Downstream Pipe		Units
	Type	Size Range	Recommend	Max.	Recommend	Max.	
Gas	PRV	1/2"-1"	0.20	0.40	0.15	0.30	Mach #
		1-1/4"-2"	0.25	0.45	0.20	0.30	
		2-1/2"-6"	0.30	0.50	0.25	0.35	
	8"-12"	-	-	0.25	0.40		
NOTES: 1. If valve outlet exceeds recommended limits, then can use external sensing to reach maximum limits. 2. On gas service, a pilot operated prv can work with a outlet Mach = 0.75.							

TABLE 12
MAXIMUM RECOMMENDED NOISE LIMITS *

Criteria	Body Sizes		Noise Level - dBA
	in	(DN)	
Per OSHA Regs. w/noise attenuation methods incorporated.	All	All	85-95
Sch. 80 pipe, no insulation.	1/2"-2"	(15-50)	95
Std. wt. pipe, no insulation.	2-1/2"-4"	(65-100)	98
* Consult Factory for ALL applications exceeding 97 dBA noise prediction.			

Schemes To Reduce High Noise –

- **Staging** – using two separate throttling valves in series.
- **dB Plates** – using 1, 2 or 3-stage dB Plate cartridges downstream of a throttling valve.
- **Paralleling** – using two separate throttling valves in parallel.
- **Combinations** – using multiple methods of above three possibilities.

TABLE 13
RECOMMENDED INTERNAL MATERIALS
For P_{max}: Reference Individual Technical Bulletins

		GASES			
Atmospheric Gases	Fluid	Tmax °F	Tmin °F	Trim	
	Atmospheric Gases –		225°	-60°	M7
	O ₂ (GOX)	350°	-65°	M9	
	N ₂ (GN ₂), Air, Argon	350°	-65°	P8	

SUPPLEMENT for TABLE 13
CHEMICAL RESISTANCE

General Statement: Statements located within this technical bulletin concerning suitability of fluids with TFE materials are general statements, and should not be construed as recommendations. Any statements of suitability are the result of a compilation of various sources of information based on experience, tests, and published technical literature. No guarantee or warranty is in anyway implied for a given particular service or application.

Additional Reference: For an inclusive listing covering a broader range of service application fluids, reference “Handbook of Corrosion Resistant Piping”, P.A. Schweitzer, Industrial Press; or “Compass Corrosion Guide”, 2nd Edition, K.M. Pruett, Compass Publications. This publication will include information based on the following fluid variables:

1. Solution concentration
2. Pressure
3. Temperature

Inverse Sympathetic Ratio (ISR) - effect on regulator performance.

PTR-1 regulators utilize a top and bottom guide, "flow to open" trim design. The top guide also acts as a "balancing" piston to oppose the forces generated by the inlet pressure acting on the valve plug. A small residual imbalance between the piston and the valve plug helps to reduce seat leakage at high differential pressures across the seat joint. This same imbalance produces an Inverse Sympathetic Ratio, ISR effect, as the delta pressure across the seat (DP) changes. The magnitude of the ISR effect is given in Table 14.

TABLE 14		
Body Size		PTR-1
in	(DN)	
1/2", 3/4", 1"	(15,20,25)	0.03
1-1/4", 1-1/2"	(32,40)	0.04
2"	(50)	0.02
2-1/2", 3", 4"	(65,80, 100)	0.054

In a similar manner the ISR effect will produce an offset between the loading pressure, PL, and the pressure setpoint of a dome loaded regulator. For example, a 4" PTR-1 with an inlet pressure, P1 of 300 psig and an outlet pressure, P2 of 50 psig would require a loading pressure, $PL = (P1 - P2) \times ISR + P2 = (300 - 50) \times 0.054 + 50 = 63.5$ psig. In addition, if the DP changes, then a setpoint offset would be observed with a constant loading pressure.

**FIGURE F1
Dynamic - Static Seals**

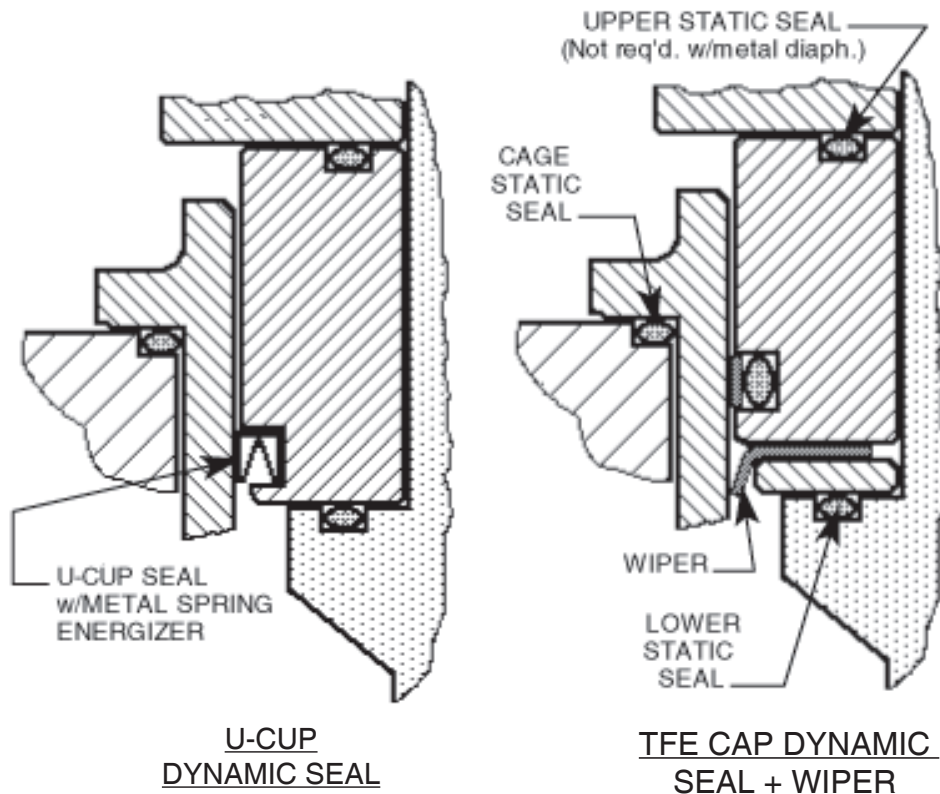
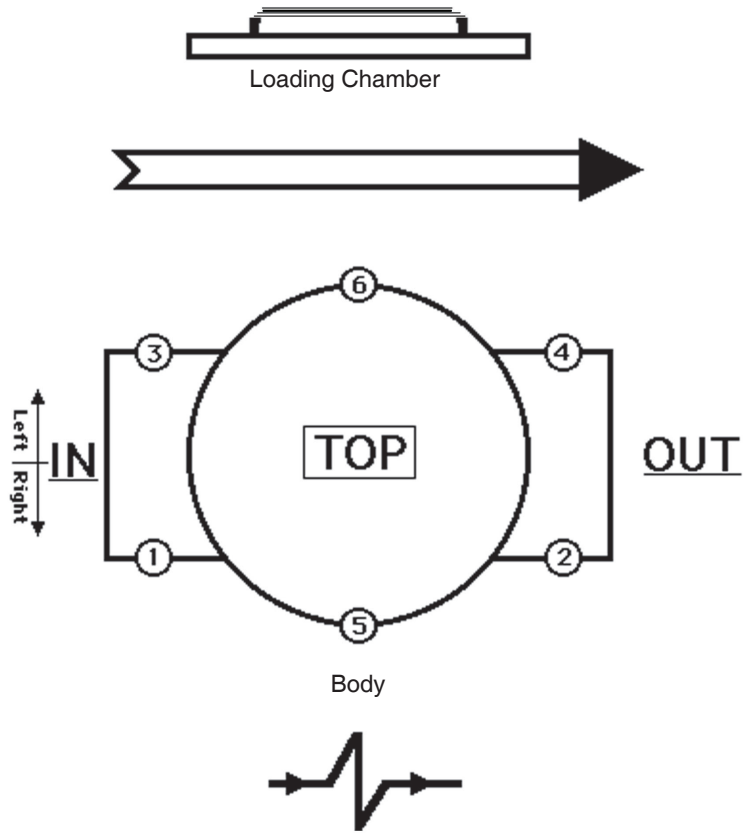

FIGURE F2
Location of BODY TAPS



Flow To Open Direction

Location	Description	Opt. No.	NPT - Size	Body Mat'l.
1 & 2	Inlet & Outlet – Right	STD	1/4"	SST
1, 2 & 3	Inlet & Outlet – Right	STD	1/4"	BRZ
5	External Sensing – Right	STD	1/4"	BRZ & SST
1, 2, 3 & 4	Inlet & Outlet – Right Inlet & Outlet – Left	85	1/4"	BRZ & SST
5 & 6	Double External Sensing	85	1/4"	BRZ & SST

The contents of this publication are presented for informational purposes only, and while every effort has been made to ensure their accuracy, they are not to be construed as warranties or guarantees, express or implied, regarding the products or services described herein or their use or applicability. We reserve the right to modify or improve the designs or specifications of such product at any time without notice. Cashco, Inc. does not assume responsibility for the selection, use or maintenance of any product. Responsibility for proper selection, use and maintenance of any Cashco, Inc. product remains solely with the purchaser.

DIMENSION and WEIGHTS

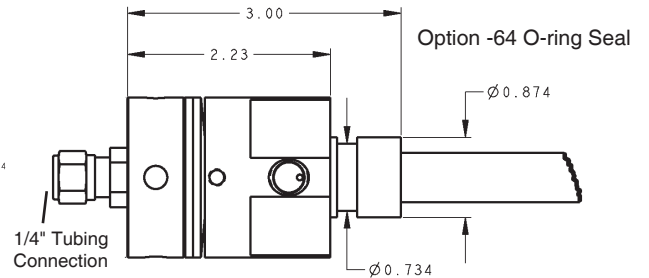
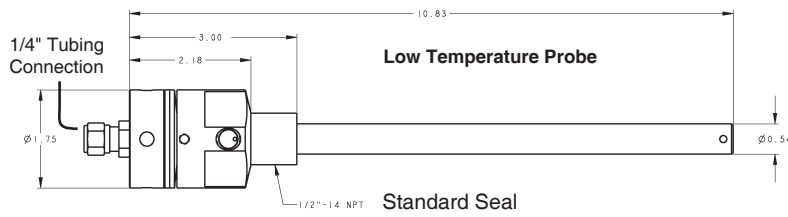
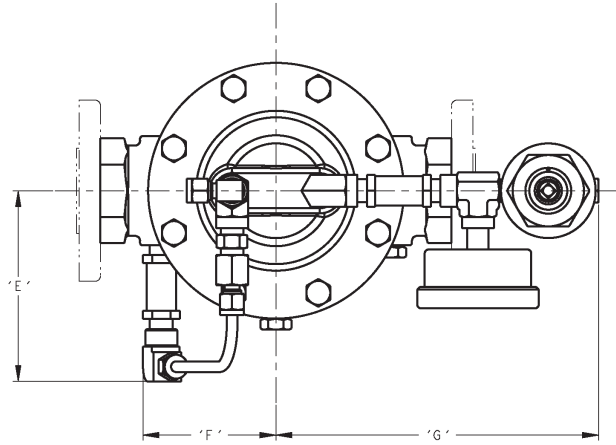
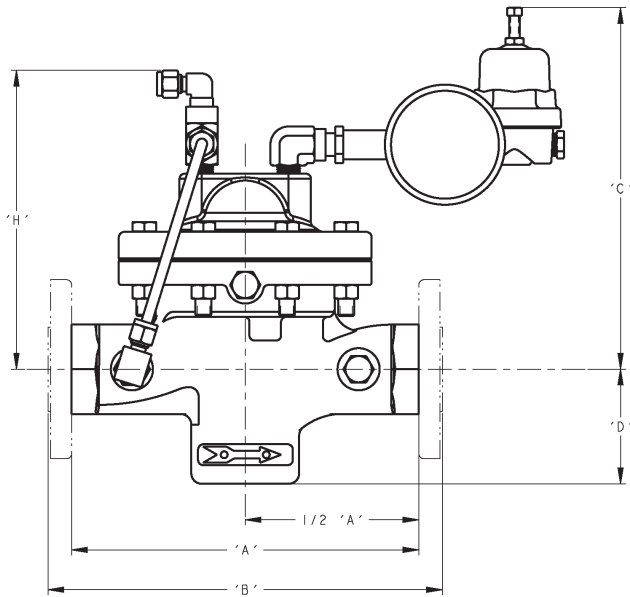

ENGLISH UNITS (in) (lbs)

DIMEN.	END CONN.	BODY MAT'L	BODY SIZE					
			1/2", 3/4 & 1"	1-1/4" & 1-1/2"	2"	2-1/2"	3"	4"
A	NPT	BRZ	6.00	9.88	9.88	-	-	-
		SST	8.25	9.88	9.75	-	-	-
B	150# FF	BRZ **	9.63	11.50 ✓	11.50	10.88	11.75	13.88
	300# FF	BRZ **	9.63	11.50 ✓	11.50	11.50	12.15	14.50
	150# RF	SST	10.75	12.38 ✓	10.00	10.88	11.75	13.88
	150# RF ‡	SST	14.00	14.00 ✓	14.00	-	-	-
	300# RF	SST,	10.75	12.38 ✓	10.50	11.50	12.50	14.50
	300# RF ‡	SST	14.00	14.00 ✓	14.00	-	-	-
	600# RF	SST	10.75	12.38 ✓	11.25	12.25	13.25	15.50
	600# RF ‡	SST	14.00	14.00 ✓	14.00	-	-	-
C	ALL	ALL	8.75	10.63	11.25	13.00	14.50	14.50
D	ALL	ALL	2.84	3.69	4.00	5.25	5.75	7.00
E	ALL	ALL	4.50	4.75	5.13	6.25	6.63	6.63
F	ALL	ALL	2.25	3.50	3.75	3.75	4.25	4.25
G	ALL	ALL	7.75	8.00	8.00	6.81	6.75	6.75
H	ALL	ALL	7.00	7.75	8.25	11.13	12.50	12.50
WEIGHT	wo/ Flanges	ALL	23	32	48	-	-	-
	w/ Flanges	ALL	28	42	61	90	155	164

METRIC UNITS (mm) (kg)

END CONN.	BODY SIZE					
	DN15, DN20 & DN25	DN32 & DN40 ✓	DN50	DN65	DN80	DN100
NPT	152	251	251	-	-	-
	209	251	248	-	-	-
150# FF	246	292 ✓	292	276	298	352
300# FF	246	292 ✓	292	292	309	368
150# RF	273	314 ✓	254	276	298	352
150# RF ‡	356	356 ✓	356	-	-	-
300# RF	273	314 ✓	267	292	318	368
300# RF ‡	356	356 ✓	356	-	-	-
600# RF	273	314 ✓	286	311	336	394
600# RF ‡	356	356 ✓	356	-	-	-
ALL	222	270	286	330	368	368
ALL	72	94	102	133	146	178
ALL	114	121	130	159	168	168
ALL	57	89	95	95	108	108
ALL	197	203	203	173	171	171
ALL	178	197	209	283	317	317
wo/ Flanges	10	14	22	-	-	-
w/ Flanges	12	19	28	41	70	74

** Flanged BRZ bodies available in sizes 1", 1-1/2", 2", 2-1/2", 3", & 4" ONLY.

✓ Flange Connection not available for 1-1/4" size.

‡ Opt-34: Special 14" F to F Flange dimensions, CS and SST body material only.

Consult Factory for dimensions of ISO DIN Flanged units. (PN16, PN25, PN40)

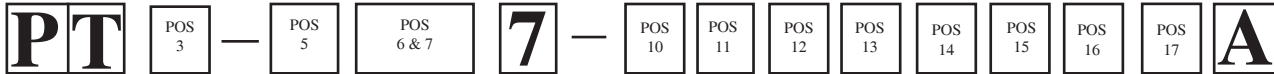

POSITION 3 - SIZES		
Size	STD	
in	(DN)	CODE
1/2"	(15)	4
3/4"	(20)	5
1"	(25)	6
1-1/4"	(32)	7
1-1/2"	(40)	8
2"	(50)	9
2-1/2"	(65)	A
3"	(80)	B
4"	(100)	C

POSITION 5 - BODY/COVER DOME MATERIALS for Main Regulator			
Materials	CODE	Materials	CODE
BRZ/BRZ *	B	SST/SST **	A

* Includes Brass Probe Constr. with Brass Head, & Thermal Element. Cleaned per #S-1134.
 ** Includes SST Probe Constr. with SST Head, & Thermal Element. Cleaned per #S-1134.
 Select Probe Set Point Temperature in Position 15.

POSITION 6 & 7 - DIAPHRAGM, SEAL & SEAT MATERIALS					
Trim	Seat (#)	Diaphragm	Static Seal	Dynamic Seal	CODE
Monel "M"	PA	FK	FK	SST/TFE u-cup ‡‡	M7 ‡
	V-TFE	FK	FK	SST/TFE u-cup	M9 ‡
	V-TFE	FKM-TFE	SST/TFE u-cup √	SST/TFE u-cup	ME
	PA	FK	FK	TFE+FK GFTFE CW	MK
316L SST "S"	GF-TFE	FKM	FKM	TFE+FKM GFTFE CW	ML
	V-TFE	FK	FK	SST/TFE u-cup	S9 ‡
17-4PH/ Monel/ 17-4PH "T"	GF-TFE	FKM	FKM	TFE+FKM GFTFE CW	SL
	PA	FK	FK	SST/TFE u-cup ‡‡	T7 ‡
	V-TFE	FK	FK	SST/TFE u-cup	T9 ‡
	PA	FK	FK	TFE+FK GFTFE CW	TK
	GF-TFE	FKM	FKM	TFE+FKM GFTFE CW	TL

‡‡ For GOX service, PA seats allowed in BRZ Bodies w/ trim materials "M" or "T" only.
 ‡ For Low Ambient Temperatures (See TABLE 5 & 13 for Min. Temperatures).
 √ Sizes 2-1/2"-4" use V-TFE static seal.

POSITION 10 - END CONNECTIONS / ASME								
Size	Material	Method	End Conn	CODE	End Conn	CODE	End Conn	CODE
1/2" - 2"	ALL	—	NPT	1	—	—	—	—
1", 1-1/2" - 4"	BRZ	Integral	150#FF	6	300#FF	7	—	—
1/2" - 3/4"	SST	Opt-30	150#RF	4	300#RF	5	600# RF	8
1" - 4"	SST	Integral *						
1/2" - 2"	ALL	Opt-31	BSP	P	—	—	—	—
END CONNECTIONS FOR ISO DIN FLANGES								
DN15-25, 40, 50	BRZ	Integral	PN40 FF - will mate with PN16, 25 and 40			J		
DN65-100			PN16 FF	K	PN25 FF	L	PN40 FF	M
DN15-25, 40, 50	SST	Opt-30	PN40 RF - will mate with PN16, 25 and 40			D		
DN65-100	SST	Integral	PN16 RF	A	PN25 RF	C	PN40 RF	G

* Flanges Not Available for 1-1/4" (DN32) size.
 ** 1" size w/ 600# RF CS, or SST has weld-on flanges Opt-30

POSITION 11 - LOWER SPRING	
Spring Range psig	CODE
No Spring	0
2-5	3
1-2 *	5

* Use with Unloader Spring Range 2 - 30 psig.

POSITION 12 - SENSING CONFIGURATION (FLOW TO OPEN)	
Option	CODE
Internal	1
External	2
For Special Construction Contact Cashco for Special Code	X

POSITION 13 - UNLOADER 1/4" NPT, S2 TRIM		
Spring Range psig	Body / Spring chamber Material	
	BRZ	SST
2 - 30	B	2
10 - 50	C	3
40 - 90	D	4
40 - 125	E	5
100 - 175	F	6
170 - 400	G	7
None	0	

POSITION 14 - FILTER-ORIFICE / FITTING / TUBING		
Filter - Orifice / Fitting / Tubing	W / Helix Coils *	CODE
Material	Yes	A
	(Std)-No	B
Brass / BR / Cu standard with BRZ Unloader	Yes	R
	(Std)-No	S
SST / SST / SST standard with SST Unloader	Yes	G
	(Std)-No	H

* See Application Notes on page 9 Table 8.

POSITION 15 - Low Temperature Probe Set Point			
TEMP °F	Br & SST	TEMP °F	Br & SST
	CODE		CODE
+50	1	-10	7
+30	2	-15	8
+25	3	-20	9
+15	4	-30	A
+10	5	-40	B
0	6	-50	C

POSITION 16 - OPTIONS - Description			Option.	CODE
No Option			—	0
O-ring Insertion Seal (for Low Temperature Probe).			-64	2

POSITION 17 - OPTIONS - Description			Option.	CODE
No Option			—	0
Second Set 1/4" (DN8) FNPT Body Pressure Taps & Plugs.			-85	T

Алматы (7273)495-231
 Ангарск (3955)60-70-56
 Архангельск (8182)63-90-72
 Астрахань (8512)99-46-04
 Барнаул (3852)73-04-60
 Белгород (4722)40-23-64
 Благовещенск (4162)22-76-07
 Брянск (4832)59-03-52
 Владивосток (423)249-28-31
 Владикавказ (8672)28-90-48
 Владимир (4922)49-43-18
 Волгоград (844)278-03-48
 Вологда (8172)26-41-59
 Воронеж (473)204-51-73
 Екатеринбург (343)384-55-89

Иваново (4932)77-34-06
 Ижевск (3412)26-03-58
 Иркутск (395)279-98-46
 Казань (843)208-01-48
 Калининград (4012)72-03-81
 Калуга (4842)82-23-67
 Кемерово (3842)65-04-62
 Киров (8332)68-02-04
 Коломна (4966)23-41-49
 Кострома (4942)77-07-48
 Краснодар (861)203-40-90
 Красноярск (391)204-63-61
 Курск (4712)77-13-04
 Курган (3522)50-90-47
 Липецк (4742)52-20-81

Магнитогорск (3519)55-03-13
 Москва (495)268-04-70
 Мурманск (8152)59-64-93
 Набережные Челны (8552)20-53-41
 Нижний Новгород (831)429-08-12
 Новокузнецк (3843)20-46-81
 Новороссийск (3496)41-32-12
 Новосибирск (383)227-86-73
 Омск (3812)21-46-40
 Орел (4862)44-53-42
 Оренбург (3532)37-68-04
 Пенза (8412)22-31-16
 Петрозаводск (8142)55-98-37
 Псков (8112)59-10-37
 Пермь (342)205-81-47

Ростов-на-Дону (863)308-18-15
 Рязань (4912)46-61-64
 Самара (846)206-03-16
 Саратов (845)249-38-78
 Севастополь (8692)22-31-93
 Симферополь (3652)67-13-56
 Смоленск (4812)29-41-54
 Сочи (862)225-72-31
 Ставрополь (8652)20-65-13
 Суругт (3462)77-98-35
 Сыктывкар (8212)25-95-17
 Тамбов (4752)50-40-97
 Тверь (4822)63-31-35

Тольятти (8482)63-91-07
 Томск (3822)98-41-53
 Тула (4872)33-79-87
 Ульяновск (8422)24-23-59
 Улан-Удэ (3012)59-97-51
 Уфа (347)229-48-12
 Хабаровск (4212)92-98-04
 Чебоксары (8352)28-53-07
 Челябинск (351)202-03-61
 Череповец (8202)49-02-64
 Чита (3022)38-34-83
 Якутск (4112)23-90-97
 Ярославль (4852)69-52-93

Россия +7(495)268-04-70

Казахстан +7(7172)727-132

Киргизия +996(312)96-26-47