



ISO Registered Company



MODEL 1000HP-1+6

MODEL 1000HP-1+8

DIFFERENTIAL PRESSURE REDUCING REGULATORS



MODEL 1000HP-1+6

OVERVIEW

Models 1000HP-1+6 or 1000HP-1+8 are differential reducing regulators used to maintain a relatively constant pressure differential between the fluid loading pressure – P_{Load} , and the valve's outlet pressure - P_2 , with P_2 pressure higher than P_{Load} pressure.

Model 1000HP-1+6 is a single-diaphragm differential construction. Model 1000HP-1+8 is a double-diaphragm differential construction. A double-diaphragm design prevents the fluid passing through the body from mixing into the loading fluid pressurizing the spring chamber in the event of a diaphragm failure.

The design takes advantage of all the features of the basic 1000HP reducing regulator; see Technical Bulletin 1000HP-BASIC-TB. The availability of optional construction and body and trim materials is limited to those indicated in this Technical Bulletin.

APPLICATIONS

Widely applied in steam atomization systems using heavy oil (Nos. 3 - 6, Bunker C) to fuel burners. Also used to maintain constant differential pressure across the multiple port flow rate control valve frequently supplied to control fuel flow to a burner.



LINE SIZES AVAILABLE

1/2" (DN15), 3/4" (DN20), 1" (DN25), 1-1/4" (DN32), 1-1/2" (DN40), 2" (DN50)



END CONNECTIONS

NPT, FLANGED, BSP, EXTENDED NIPPLES, 14" FACE TO FACE



COMMON APPLICATIONS

STEAM, HEAVY OIL



DESIGN PRESSURE

INLET: UP TO 740 psig (51 Barg)
OUTLET: UP TO 300 psig (20.7 Barg)

Алматы (7273)495-231
Ангарск (3955)160-70-56
Архангельск (8182)53-90-72
Астрахань (8512)99-46-04
Барнаул (3852)73-04-60
Белгород (4722)40-23-64
Благовещенск (4162)22-76-07
Брянск (4832)59-03-52
Владивосток (423)249-28-31
Владикавказ (8672)28-90-48
Владимир (4922)49-43-18
Волгоград (844)278-03-48
Вологда (8172)26-41-59
Воронеж (473)204-51-73
Екатеринбург (343)384-55-89

Иваново (4932)77-34-06
Ижевск (3412)26-03-58
Иркутск (395)279-98-46
Казань (843)206-01-48
Калининград (4012)72-03-81
Калуга (4842)92-23-67
Кемерово (3842)65-04-62
Киров (8332)68-02-04
Коломна (4966)23-41-49
Кострома (4942)77-07-48
Краснодар (861)203-40-90
Красноярск (391)204-63-61
Курск (4712)77-13-04
Курган (3522)50-90-47
Липецк (4742)52-20-81

Магнитогорск (3519)55-03-13
Москва (495)268-04-70
Мурманск (8152)59-64-93
Набережные Челны (8552)20-53-41
Нижний Новгород (831)429-08-12
Новокузнецк (3843)20-46-81
Новосибирск (383)227-86-73
Омск (3812)21-46-40
Орел (4862)44-53-42
Оренбург (3532)37-68-04
Пенза (8412)22-31-16
Петрозаводск (8142)55-98-37
Псков (8112)59-10-37
Пермь (342)205-81-47

Ростов-на-Дону (863)308-18-15
Рязань (4912)46-61-64
Самара (846)206-03-16
Санкт-Петербург (812)309-46-40
Саратов (845)249-38-78
Севастополь (8692)22-31-93
Саранск (8342)22-96-24
Симферополь (3652)67-13-56
Смоленск (4812)29-41-54
Сочи (862)225-72-31
Ставрополь (8652)20-65-13
Сургут (3462)77-98-35
Сыктывкар (8212)25-95-17
Тамбов (4752)50-40-97
Тверь (4822)63-31-35

Тольятти (8482)63-91-07
Томск (3822)98-41-53
Тула (4872)33-79-87
Тюмень (3452)68-21-18
Ульяновск (8422)24-23-59
Улан-Уда (3012)59-97-51
Уфа (347)229-48-12
Хабаровск (4212)92-98-04
Чебоксары (8352)28-53-07
Челябинск (351)202-03-61
Череповец (8202)49-02-64
Чита (3022)38-34-83
Якутск (4112)23-90-97
Ярославль (4852)69-52-93

Россия +7(495)268-04-70

Казахстан +7(7172)727-132

Киргизия +996(312)96-26-47

STANDARD GENERAL SPECIFICATIONS

Body Sizes: 1/2", 3/4", 1", 1-1/4", 1-1/2" and 2";
(DN15, 20, 25, 32, 40 and 50).

End Connections: Standard – NPT female.
Opt-30: 150# or 300# RF flanged.
Opt-31: BSP female.
Opt-32: Extended plain end nipples.
Opt-34: 14" Face to Face Flange
Dim. (Sizes 1/2"- 1"& 1-1/2" only)

Body/Spring Chamber Material Combinations: Uniform – DI/DI and CS/CS.
Combinations – CS/DI and BRZ/DI.

Combinations: DI = Ductile iron
CS = Cast carbon steel
BRZ = Cast bronze
See Table 4 for material specifications.
NOTE: BRZ spring chambers are not available.

Trim Designs: Metal seated or composition seat (see Figure 1). Metal or composition diaphragms.

"B_" series designations – BRZ, BR, SST; see Table 6 for materials.
"S_" series designations – SST; see Table 7 for materials.
DI/BRZ, DI/SST.

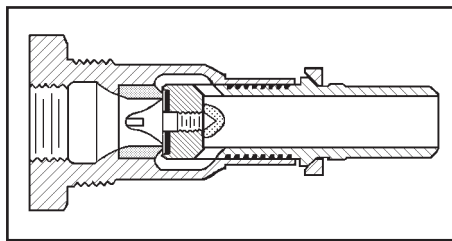

Figure 1: Composition Seat Design

Body/Cylinder Material Combinations: BRZ/BRZ.
CS/SST.

Maximum Inlet Operating Pressure: All materials – 400 psig (27.6 Barg)
(Consult factory for higher pressures).

NOTES: 1. 1000HP is a flow-to-open (FTO) design; this places an upper

limitation on inlet pressure for a given differential (range spring) pressure setting.

2. See Table 3 for max. allowable pressure levels.

Temperature Range:

Inlet and Outlet, All Materials –

Liquid or Gas

-20° to +400°F

(-29° to +205°C).

Steam

406°F - SAT @ 250 psig

(208°C - SAT @ 17.2 Barg).

NOTE: Composition trim or gasket materials may lower above ranges.

Differential Pressure Range:

Normal Operating: 10–100 psid
(0.7–6.9 Bard).

See Table 1 for individual range spring spans.

NOTE: 1000HP is a flow-to-open (FTO) design; this places a lower limitation on differential pressure setting for some inlet pressure levels.

$$P_2 = P_{\text{Load}} + \Delta P_{\text{Diff}}$$

$$\text{Max } P_{\text{Load}} = \text{Max } P_2 - \text{Max } \Delta P_{\text{Diff}}$$

Maximum Loading Pressure:

All materials –300 psig (20.7 Barg).

Maximum Outlet Pressure:

See Table 3.

NOTES: Maximum safety relief set-point is not to exceed 1.10 x Maximum Normal Outlet Pressure.

Minimum Pressure Drop:

$\Delta P > 5$ psid (0.34 Bard).

Seat Leakage:

Meets ANSI/FCI 70-2.

Metal Seated – Class IV.

Composition Seat – Class VI.

Range Springs: Standard: Epoxy coated steel.

Diaphragm Flange Bolting: Standard: High strength, zinc plated, heat treated steel. For all body/spring chamber materials.

Gaskets: Required for metal diaphragm constructions only; not required for composition diaphragm construction.
Standard: Graphite/NBR.
Not suitable for Oxygen Service. $T_{max} = 400^{\circ}\text{F}$ (205°C).

Spring Chamber Vent Valve: Plated carbon steel.

Painting: Standard: All non-corrosion resistant portions to be painted with corrosion resistant epoxy paint per Cashco Spec #S-1606.

OPTION SPECIFICATIONS

This section indicates special variations which are available to the standard Model 1000HP-DIFF products. Multiple options may be selected; i.e. 1000HP-1+6+15, which is the 1000HP-1+6 product plus Opt-15 together.

Option -1 (Std.): CLOSING CAP. A removable ductile iron cap discourages tampering with spring setting. Includes a gasket for sealing the closing cap to the spring chamber, a sealing lock nut and a 1/4" NPT female vent connection.

Seat ring is silver brazed to cylinder for "B_" series **composition** trim designations, and to 1/2" (DN15) body size cylinders with "S_" series trim designations. For all other body sizes with "S_" series designations the seat ring is welded to the cylinder.

Option -12: REDUCED PORT ORIFICE. Used when high inlet pressure negates use of the standard full port orifice. Also used when oversized body is desired to accommodate piping size. Available in metal seated or composition seat materials, in all "B_" or "S_" series trim designations, and in all body sizes except 1-1/4" (DN32). See Tables 9 and 11 for flow capacity in Cv's.

NOTE: Opt-14 is now included whenever Opt-15, stellite seat surfaces is specified.

Option -14: INTEGRAL SEAT. Standard pressed-in seat ring-to-cylinder joint is sealed as a path of leakage by brazing or welding. The procedure also serves as a permanent joint for flow conditions where service conditions are "severe", subject to vibration, or thermal cycling.

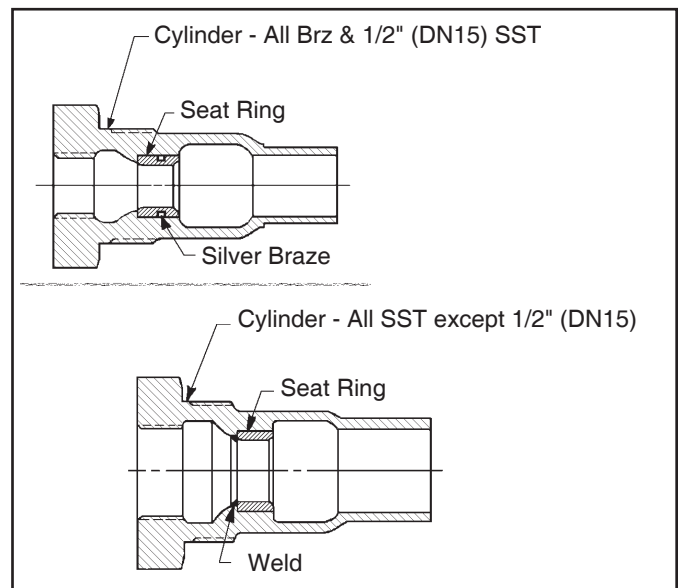

Figure 2: Opt-14 Integral Seat

Option -15: STELLITED SEAT SURFACES. Available with metal seated S1 trim only, and with full port orifice or Opt-12 reduced port orifice. Both plug face and seat ring's seat edge are coated with stellite hard surfacing using a flame spray process. Always includes integral seat ring Opt-14.

Option -17: PISTON SPRING. Required for applications where pressure drop is less than 5 psid (0.34 Bard). Minimizes plug/cylinder frictional effects. 302 SST material only.

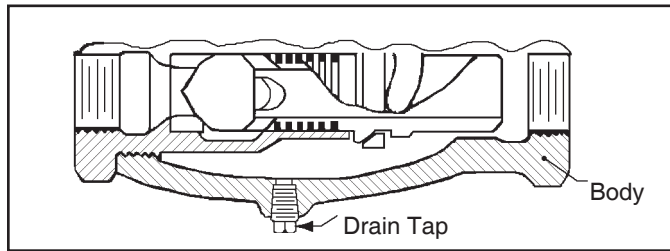

Figure 3: Opt-26 Drain Hole

Option -26: DRAIN HOLE. 1/4" NPT drain tap with plug in body underside. Recommend use with highly viscous fluids (above 100 centipoise (Cp)) for downstream piping pressure sensing. Plug material similar to body material. Recommended for flashing liquids.

Option -27: VISCOUS LIQUID SERVICE. Incorporates special valve plug with drilled openings near the "jet effect" zone to stabilize operation for fluids with viscosity greater than 100 Cp. Brass or SST metal seated trim ONLY.

Option -30: FLANGED END CONNECTIONS. CS body material only. Flange and pipe nipple materials of same general chemistry as body material. Available as 150# RF or 300# RF flange configurations per ASME B16.5 Group 1.1. Requires lapped joint-type flange on inlet (cylinder) end. Pipe nipples socket welded to body and cylinder. Outlet connection flange is socket weld-type. See Table 14 for lowered P vs T ratings. No post-weld stress relieving performed. Not available for 1-1/4" body size.

Option -31: BSP SCREWED END CONNECTIONS. British Standard Pipe threads per ISO 7/1; used as alternate to NPT ends. Available all sizes and body materials.

Option -32: EXTENDED P.E. NIPPLES. Schedule 80 plain end pipe nipples used for field butt or socket welding into pipeline. Pipe nipples of same general chemistry as body material. Short-threaded pipe nipples seal welded to body and cylinder. Adds approximately 8 inches (200 mm) to the face-to-face dimension of standard unit.

Option -34: SPECIAL 14" FACE TO FACE DIMENSION FOR FLANGED END CONNECTIONS. Sizes 1/2" - 1" & 1-1/2" only. See Opt.-30 for standard face to face dimension.

Option -65: FLOW-THRU SPRING CHAMBER. Spring chamber provided with two female NPT connections on spring chamber, allowing loading pressurizing fluid to be recirculated. Recommended for heavy oils with high paraffin content. CS spring chamber only. Tapped connection sizes dependent on body size:

Body Size		Tapped Connection Sizes - inch
inch	(DN)	
1/2"	(15)	1/2" NPT
3/4"	(20)	1/2" NPT
1"	(25)	3/4" NPT
1-1/4"	(32)	1" NPT
1-1/2"	(40)	1" NPT
2"	(50)	1-1/4" NPT

Utilized in harsh atmospheric conditions.

TECHNICAL SPECIFICATIONS

**TABLE 1
RANGE SPRINGS**

Body Size		Standard – Steel	
In.	(DN)	psid	(Bard)
1/2"	(15)	10 – 50	(.7–3.4)
		40–100	(2.7–6.9)
3/4"	(20)	10 – 40	(.7–2.7)
		30 – 60	(2.1–4.1)
		50 – 90	(3.4–6.2)
		70–100	(4.8–6.9)
1"	(25)	10 – 40	(.7–2.7)
		30 – 60	(2.1–4.1)
		50 – 70	(3.4–4.8)
		55 – 80	(3.8–5.5)
1-1/4"	(32)	65–100	(4.5–6.9)
		10 – 40	(.7–2.7)
		30 – 50	(2.1–3.4)
		40 – 60	(2.7–4.1)
1-1/2"	(40)	50 – 90	(3.4–6.2)
		70–100	(4.8–6.9)
		10 – 40	(.7–2.7)
2"	(50)	30 – 75	(2.1–5.2)
		60–100	(4.1–6.9)
		10 – 40	(.7–2.7)
2"	(50)	30 – 60	(2.1–4.1)
		50–100	(3.4–6.9)

**TABLE 2
MAXIMUM CAPACITY – Cv
FOR SIZING SAFETY RELIEF DEVICE
(WITH PLUG WIDE OPEN)**

Body Size		Orifice Size			
		Standard		Opt. -12 Reduced	
In.	(DN)	Size	Cv	Size	Cv
1/2"	(15)	1/2"	5	3/8"	3
3/4"	(20)	3/4"	9	1/2"	7
1"	(25)	7/8"	9	5/8"	8
1-1/4"	(32)	1"	13	NA ¹	NA ¹
1-1/2"	(40)	1-1/4"	17	7/8"	13
2"	(50)	1-1/2"	22	1-1/4"	20

- NOTES:**
1. NA = Not Available.
 2. See Footnote 1 of Table 13 for technical information on safety relief valve or rupture disc setpoint pressure.

METRIC CONVERSION FACTOR: Cv / 1.16 - kv

TABLE 3
MAXIMUM ALLOWABLE PRESSURE vs. TEMPERATURE;
FOR PRESSURE CONTAINMENT OF
BODY, SPRING CHAMBER AND CYLINDER
(See Table 4 for Material Specifications)

Materials of Construction ¹	Inlet – Cylinder				Outlet – Body & Spring Chamber			
	Pressure		Temperature		Pressure ²		Temperature	
	psig	(Barg)	°F	(°C)	psig	(Barg)	°F	(°C)
DI / DI / BRZ BRZ / DI / BRZ	400	(27.6)	-20 to +150	(-29 to +66)	300	(20.7)	-20 to +300	(-29 to +149)
	385	(26.5)	+200	(+94)	250	(17.2)	+400	(+205)
	365	(25.2)	+250	(+121)				
	335	(23.1)	+300	(+149)				
	300	(20.7)	+350	(+177)				
	250	(17.2)	+400	(+205)				
DI / DI / SST CS / DI / SST	740	(51.0)	-20 to +400	(-29 to +205)	300	(20.7)	-20 to +300	(-29 to +149)
					250	(17.2)	+400	(+205)
CS / CS / SST	740	(51.0)	-20 to +400	(-29 to +205)	400	(27.6)	-20 to +400	(-29 to +205)

¹ Pressure vs. temperature ratings in accordance with ASME B31.3

² Pressure level given based on $P_{Load} + \Delta P_{Diff}$ sum.

TABLE 4
MATERIAL SPECIFICATIONS OF
BODY, SPRING CHAMBER AND CYLINDER

Material	ASTM Specifications
BRZ - cast bronze	B62, Alloy 83600
DI - ductile iron	A395 Gr. 60-40-18
CS - cast carbon steel	A216, Gr. WCC (Body)
	A216, Gr. WCB (Spring Chamber)
SST - cast stainless steel	A351, Gr. CF8M (cast 316 SST)
	A479 UNS 31600/03

**TABLE 5
APPLICATIONS**

Fluid – Through Body	Recommended Construction	Trim Number ¹
Air or Inert Gases	Composition Seat & Diaphragm Metal Seat & Composition Diaphragm	BB, B2, B3, BK, S40V S2N
Liquids	Metal Seat & Diaphragm Composition Seat & Diaphragm	S1 BB, B2, B3, BK, S40V
Chemicals	Metal Seat & Composition Diaphragm Composition Seat & Diaphragm	S5, S40 S3
Fuel Oil	Composition Seat & Diaphragm	BB, BK, SB, S40V
Hydrocarbon Gas or Liquids	Composition Seat & Diaphragm	BB, BK, B2, B3, S3, SB, S40V
Steam, Saturated or Superheated	Metal Seat & Diaphragm	B1, S1, S2
Water and Condensate, Low Temperature (32 – 180°F)	Composition Seat & Diaphragm Metal Seat & Composition Diaphragm	BB, BK, B2, B3, S3, SB, S40V S2N
Water and Condensate High Temperature (180 – 300°F)	Metal Seat & Diaphragm	B1, S1 or S2

¹ S1 trim is available with stellite faced plug and valve seat (Opt. -15).

**TABLE 6
BRASS TRIM MATERIAL COMBINATIONS**

Part	Brass Trim #					
	B1	B2	B3	B5	BB	BK
Diaphragm	302 SST	BC	BC	Phos. Bronze	NBR	FKM
Cylinder	Brass	Brass	Brass	Brass	Brass	Brass
Valve Seat	316 SST	Brass	Brass	Brass	Brass	Brass
Plug	416 SST	Brass	Brass	Brass	Brass	Brass
Seat Disc	None (metal †)	NBR	TFE	TFE	NBR	FKM
Seat Disc Screw	None	Brass	Brass	Brass	Brass	Brass
Plug Collar	Brass	Brass	Brass	Brass	Brass	Brass
Rocker Arm Shaft	Brass	Brass	Brass	Brass	Brass	Brass
Rocker Arm	Sizes 1/2" - 1" = SST CF8M			Sizes 1-1/4" - 2" = Bronze		
Pusher Plate & Stud 3/8" – 1-1/4" body sizes	416 SST	416 SST	416 SST	416 SST	416 SST	416 SST
Pusher Plate Stud 1-1/2" & 2" body sizes	416 SST	416 SST	416 SST	416 SST	416 SST	416 SST
Pusher Plate 1-1/2" & 2" body sizes	Bronze	Bronze	Bronze	Bronze	Bronze	Bronze
Stud Collar	Brass	Brass	Brass	Brass	Brass	Brass
Cotter Pin	Brass	Brass	Brass	Brass	Brass	Brass
Nut	Brass	Brass	Brass	Brass	Brass	Brass
Temperature Range °F	-20 to +400	-20 to +180	-20 to +180	-20 to +200	-20 to +180	-20 to +400
Temperature Range °C	-29 to +205	-29 to +83	-29 to +83	-29 to +93	-29 to +83	-26 to +205
Available Optional Construction	-1+6 and -1+8	-1+6	-1+6	-1+6	-1+6	-1+6

BC = Neoprene. NBR = Buna-N. TFE = Polytetrafluoroethylene. FKM = Fluorocarbon elastomer.

† Cashco, Inc. does not recommend metal seated trim on any service where the flow will be dead ended down stream of the pressure reducing regulator.

TABLE 7
STAINLESS STEEL TRIM MATERIAL COMBINATIONS

Part	Stainless Steel Trim #									
	S1 ¹	S2	S2N	S3	S3N	S5	S40V	SB	S36	S40
Diaphragm	302 SST	302 SST	BC	BC	BC	FKM	FKM	NBR	302 ST	BC
Cylinder	CF8M	CF8M	CF8M	CF8M	CF8M	CF8M	CF8M	CF8M	CF8M	CF8M
Valve Seat	316 SST	316 SST	316 SST	316 SST	316 SST	316 SST	316 SST	316 SST	316 SST	316 SST
Plug	316 SST	416 SST	416 SST	316 SST	316 SST	416 SST	316 SST	316 SST	316 SST	316 SST
Seat Disc	None (Metal †)	None (Metal †)	None (Metal †)	TFE	NBR	None (Metal †)	FKM	NBR	TFE	None (Metal †)
Seat Disc Screw	None	None	None	316 SST	316 SST	None	316 SST	316 SST	316 SST	None
Plug Collar	316 SST	316 SST	316 SST	316 SST	316 SST	316 SST	316 SST	316 SST	316 SST	316 SST
Rocker Arm Shaft	316 SST	316 SST	316 SST	316 SST	316 SST	316 SST	316 SST	316 SST	316 SST	316 SST
Rocker Arm	CF8M	CF8M	CF8M	CF8M	CF8M	CF8M	CF8M	CF8M	CF8M	CF8M
Pusher Plate & Stud 3/8" – 1-1/4" Sizes	416 SST	416 SST	416 SST	416 SST	416 SST	416 SST	416 SST	416 SST	416 SST	416 SST
Pusher Plate Stud 1-1/2" & 2"	416 SST	416 SST	416 SST	416 SST	416 SST	416 SST	416 SST	416 SST	416 SST	416 SST
Pusher Plate 1-1/2" & 2"	316 SST	316 SST	316 SST	316 SST	316 SST	316 SST	316 SST	316 SST	316 SST	316 SST
Stud Collar	316 SST	316 SST	316 SST	316 SST	316 SST	316 SST	316 SST	316 SST	316 SST	316 SST
Cotter Pin	316 SST	316 SST	316 SST	316 SST	316 SST	316 SST	316 SST	316 SST	316 SST	316 SST
Nut	316 SST	316 SST	316 SST	316 SST	316 SST	316 SST	316 SST	316 SST	316 SST	316 SST
Temperature Range °F	-20 to +400		-20 to +180			-20 to +400		-20 to +180	-20 to +400	-20 to +180
Temperature Range °C	-29 to +205		-29 to +83			-29 to +205		-29 to +83	-29 to +205	-29 to +83
Available Optional Construction	-1+6 and -1+8		-1+6			-1+6		-1+6	-1+6	-1+6

¹ Available with Stellite faced plug and valve seat (Opt. -15). Includes a screwed-in seat cone.
BC = Neoprene. NBR = Buna-N. FKM = Fluorocarbon Elastomer. TFE = Polytetrafluoroethylene.

† Cashco, Inc. does not recommend metal seated trim on any service where the flow will be dead ended down stream of the pressure reducing regulator.

TABLE 8
**LOADING CHAMBER TOPWORKS -
MATERIALS OF CONSTRUCTION**

Variation	Part	Material	
-1+6 and -1+8	Adjusting Screw	Zn Plated Steel	
	Spring Button	CI	
	Pressure Plate	SST - through 1" Body Sizes	
		CS - 1-1/4" through 2" body Sizes	
	Range Spring	Epoxy Coated Steel	
	Pressure Plate Nut	Zn Plated Steel	
	O-Ring	FKM	
Adj. Screw Lock Nut	Zn Plated Steel w/Nylon Insert		
-1+8 Only	Body Spacer	CS	
	Diaphragm Spacer	CS	

TABLE 9
Cv – FLOW CAPACITY of 1000HP-1+6

FULL PORT – COMPOSITION DIAPHRAGM

$(F_L = 0.93)$

COMPOSITION DIAPHRAGM – SIZE – 1/2" (DN15) – FULL PORT										
Differential Pressure - ΔP_{Diff}		Max Inlet Pressure				Cv @ % DROOP			Range Spring	
		Metal Seated		Composition Seated						
psid	(Bard)	psig	(Barg)	psig	(Barg)	10%	20%	30%	psid	(Bard)
10	(0.7)	185	(12.8)	185	(12.8)	0.71	1.30	1.89	10–50	(0.7–3.4)
15	(1.0)	300	(20.7)	300	(20.7)	0.77	1.39	1.98	10–50	(0.7–3.4)
20	(1.4)	300	(20.7)	300	(20.7)	0.84	1.48	2.08	10–50	(0.7–3.4)
25	(1.7)	400	(27.6)	400	(27.6)	0.90	1.57	2.17	10–50	(0.7–3.4)
35	(2.4)	400	(27.6)	400	(27.6)	1.03	1.74	2.35	10–50	(0.7–3.4)
50	(3.4)	400	(27.6)	400	(27.6)	1.33	2.17	2.82	40–100	(2.8–6.9)
75	(5.2)	400	(27.6)	400	(27.6)	1.58	2.52	3.43	40–100	(2.8–6.9)
100	(6.9)	400	(27.6)	400	(27.6)	1.83	2.87	3.50	40–100	(2.8–6.9)

COMPOSITION DIAPHRAGM – SIZE – 3/4" (DN20) – FULL PORT										
Differential Pressure - ΔP_{Diff}		Max Inlet Pressure				Cv @ % DROOP			Range Spring	
		Metal Seated		Composition Seated						
psid	(Bard)	psig	(Barg)	psig	(Barg)	10%	20%	30%	psid	(Bard)
10	(0.7)	145	(10.0)	145	(10.0)	1.16	2.23	2.86	10–40	(0.7–2.8)
15	(1.0)	230	(15.9)	230	(15.9)	1.26	2.34	3.00	10–40	(0.7–2.8)
20	(1.4)	320	(22.1)	320	(22.1)	1.37	2.44	3.15	10–40	(0.7–2.8)
25	(1.7)	400	(27.6)	400	(27.6)	1.47	2.55	3.29	10–40	(0.7–2.8)
35	(2.4)	400	(27.6)	400	(27.6)	1.97	3.15	4.12	30–60	(2.1–4.1)
50	(3.4)	400	(27.6)	400	(27.6)	2.30	2.69	4.85	30–60	(2.1–4.1)
75	(5.2)	400	(27.6)	400	(27.6)	2.83	4.77	5.00	50–90	(3.4–6.2)
90	(6.2)	400	(27.6)	400	(27.6)	3.15	5.00	5.00	50–90	(3.4–6.2)
100	(6.9)	400	(27.6)	400	(27.6)	3.33	5.00	5.00	70–100	(4.8–6.9)

COMPOSITION DIAPHRAGM – SIZE – 1" (DN25) – FULL PORT										
Differential Pressure - ΔP_{Diff}		Max Inlet Pressure				Cv @ % DROOP			Range Spring	
		Metal Seated		Composition Seated						
psid	(Bard)	psig	(Barg)	psig	(Barg)	10%	20%	30%	psid	(Bard)
10	(0.7)	130	(9.0)	130	(9.0)	1.25	2.41	3.61	10–40	(0.7–2.8)
15	(1.0)	205	(14.1)	205	(14.1)	1.40	2.69	3.81	10–40	(0.7–2.8)
20	(1.4)	285	(19.7)	285	(19.7)	1.55	2.96	4.01	10–40	(0.7–2.8)
25	(1.7)	360	(24.8)	360	(24.8)	1.70	3.24	4.21	10–40	(0.7–2.8)
35	(2.4)	400	(27.6)	400	(27.6)	2.49	4.21	5.07	30–60	(2.1–4.1)
50	(3.4)	400	(27.6)	400	(27.6)	2.90	5.00	6.00	30–60	(2.1–4.1)
75	(5.2)	400	(27.6)	400	(27.6)	3.67	6.00	6.00	55–80	(3.8–5.5)
80	(5.5)	400	(27.6)	400	(27.6)	3.82	6.00	6.00	55–80	(3.8–5.5)
100	(6.9)	400	(27.6)	400	(27.6)	3.85	6.00	6.00	65–100	(4.5–6.9)

METRIC CONVERSION FACTOR: Cv / 1.16 = kv

TABLE 9 (Continued)
Cv – FLOW CAPACITY of 1000HP-1+6

FULL PORT – COMPOSITION DIAPHRAGM

$(F_L = 0.93)$

COMPOSITION DIAPHRAGM – SIZE – 1-1/4" (DN32) – FULL PORT										
Differential Pressure - ΔP_{Diff}		Max Inlet Pressure				Cv @ % DROOP			Range Spring	
		Metal Seated		Composition Seated						
psid	(Bard)	psig	(Barg)	psig	(Barg)	10%	20%	30%	psid	(Bard)
10	(0.7)	105	(7.2)	105	(7.2)	1.83	4.07	6.25	10–40	(0.7–2.8)
15	(1.0)	170	(11.7)	170	(11.7)	2.11	4.55	6.69	10–40	(0.7–2.8)
20	(1.4)	235	(16.2)	235	(16.2)	2.40	5.03	7.13	10–40	(0.7–2.8)
25	(1.7)	300	(20.7)	300	(20.7)	2.68	5.51	7.58	10–40	(0.7–2.8)
35	(2.4)	380	(26.2)	380	(26.2)	4.10	7.70	9.00	30–50	(2.1–3.4)
50	(3.4)	400	(27.6)	400	(27.6)	5.30	8.83	9.00	40–60	(2.7–4.1)
75	(5.2)	400	(27.6)	400	(27.6)	7.70	9.00	9.00	50–90	(3.4–6.2)
90	(6.2)	400	(27.6)	400	(27.6)	8.50	9.00	9.00	50–90	(3.4–6.2)
100	(6.9)	400	(27.6)	400	(27.6)	8.68	9.00	9.00	70–100	(4.8–6.9)

COMPOSITION DIAPHRAGM – SIZE – 1-1/2" (DN40) – FULL PORT										
Differential Pressure - ΔP_{Diff}		Max Inlet Pressure				Cv @ % DROOP			Range Spring	
		Metal Seated		Composition Seated						
psid	(Bard)	psig	(Barg)	psig	(Barg)	10%	20%	30%	psid	(Bard)
10	(0.7)	110	(7.6)	110	(7.6)	2.37	4.59	6.87	10–40	(0.7–2.8)
15	(1.0)	180	(12.4)	180	(12.4)	2.75	5.20	7.38	10–40	(0.7–2.8)
20	(1.4)	245	(16.9)	245	(16.9)	3.14	5.80	7.90	10–40	(0.7–2.8)
25	(1.7)	315	(21.7)	315	(21.7)	3.52	6.41	8.41	10–40	(0.7–2.8)
35	(2.4)	395	(27.3)	395	(27.3)	4.40	8.80	10.00	30–75	(2.1–5.2)
50	(3.4)	400	(27.6)	400	(27.6)	5.50	9.05	10.55	30–75	(2.1–5.2)
75	(5.2)	400	(27.6)	400	(27.6)	6.35	9.65	10.90	60–100	(4.1–6.9)
100	(6.9)	400	(27.6)	400	(27.6)	7.20	10.20	11.00	60–100	(4.1–6.9)

COMPOSITION DIAPHRAGM – SIZE – 2" (DN50) – FULL PORT										
Differential Pressure - ΔP_{Diff}		Max Inlet Pressure				Cv @ % DROOP			Range Spring	
		Metal Seated		Composition Seated						
psid	(Bard)	psig	(Barg)	psig	(Barg)	10%	20%	30%	psid	(Bard)
10	(0.7)	120	(8.3)	120	(8.3)	3.60	7.27	10.30	10–40	(0.7–2.8)
15	(1.0)	220	(15.2)	220	(15.2)	3.84	7.60	10.83	10–40	(0.7–2.8)
20	(1.4)	315	(21.7)	315	(21.7)	4.08	7.92	11.36	10–40	(0.7–2.8)
25	(1.7)	400	(27.6)	400	(27.6)	4.32	8.25	11.89	10–40	(0.7–2.8)
35	(2.4)	400	(27.6)	400	(27.7)	7.90	11.05	12.80	30–60	(2.1–4.1)
50	(3.4)	400	(27.6)	400	(27.6)	8.80	11.75	13.00	30–60	(2.1–4.1)
60	(4.1)	400	(27.6)	400	(27.6)	9.10	12.00	13.00	30–60	(2.1–4.1)
75	(5.2)	400	(27.6)	400	(27.6)	7.27	10.63	12.37	50–100	(3.4–6.9)
100	(6.9)	400	(27.6)	400	(27.6)	7.78	10.95	12.70	50–100	(3.4–6.9)

METRIC CONVERSION FACTOR: Cv / 1.16 - kv

TABLE 10
Cv – FLOW CAPACITY of 1000HP-1+6

OPT -12, 1-STEP REDUCED PORT – COMPOSITION DIAPHRAGM

$(F_L = 0.93)$

COMPOSITION DIAPHRAGM – SIZE – 1/2" (DN15) – 1-STEP REDUCED PORT										
Differential Pressure - ΔP_{Diff}		Max Inlet Pressure				Cv @ % DROOP			Range Spring	
		Metal Seated		Composition Seated						
psid	(Bard)	psig	(Barg)	psig	(Barg)	10%	20%	30%	psid	(Bard)
10	(0.7)	200	(13.8)	220	(15.2)	0.47	1.00	1.55	10–50	(0.7–3.4)
15	(1.0)	335	(23.1)	370	(25.5)	0.53	1.10	1.61	10–50	(0.7–3.4)
20	(1.4)	400	(27.6)	400	(27.6)	0.60	1.18	1.68	10–50	(0.7–3.4)
25	(1.7)	400	(27.6)	400	(27.6)	0.66	1.26	1.74	10–50	(0.7–3.4)
35	(2.4)	400	(27.6)	400	(27.6)	0.78	1.42	1.86	10–50	(0.7–3.4)
50	(3.4)	400	(27.6)	400	(27.6)	1.06	1.79	2.22	40–100	(2.8–6.9)
75	(5.2)	400	(27.6)	400	(27.6)	1.26	2.09	2.36	40–100	(2.8–6.9)
100	(6.9)	400	(27.6)	400	(27.6)	1.39	2.29	2.50	40–100	(2.8–6.9)

COMPOSITION DIAPHRAGM – SIZE – 3/4" (DN20) – 1-STEP REDUCED PORT										
Differential Pressure - ΔP_{Diff}		Max Inlet Pressure				Cv @ % DROOP			Range Spring	
		Metal Seated		Composition Seated						
psid	(Bard)	psig	(Barg)	psig	(Barg)	10%	20%	30%	psid	(Bard)
10	(0.7)	175	(12.1)	300	(20.7)	0.71	1.30	1.89	10–40	(0.7–2.8)
15	(1.0)	280	(19.3)	400	(27.6)	0.77	1.39	1.98	10–40	(0.7–2.8)
20	(1.4)	380	(26.2)	400	(27.6)	0.84	1.48	2.08	10–40	(0.7–2.8)
25	(1.7)	400	(27.6)	400	(27.6)	0.90	1.57	2.17	10–40	(0.7–2.8)
35	(2.4)	400	(27.6)	400	(27.6)	1.03	1.74	2.35	30–60	(2.1–4.1)
50	(3.4)	400	(27.6)	400	(27.6)	1.33	2.17	2.82	30–60	(2.1–4.1)
75	(5.2)	400	(27.6)	400	(27.6)	1.58	2.52	3.43	50–90	(3.4–6.2)
90	(6.2)	400	(27.6)	400	(27.6)	1.68	2.68	3.50	50–90	(3.4–6.2)
100	(6.9)	400	(27.6)	400	(27.6)	2.07	3.35	3.50	70–100	(4.8–6.9)

COMPOSITION DIAPHRAGM – SIZE – 1" (DN25) – 1-STEP REDUCED PORT										
Differential Pressure - ΔP_{Diff}		Max Inlet Pressure				Cv @ % DROOP			Range Spring	
		Metal Seated		Composition Seated						
psid	(Bard)	psig	(Barg)	psig	(Barg)	10%	20%	30%	psid	(Bard)
10	(0.7)	170	(11.7)	250	(17.2)	0.86	1.72	2.57	10–40	(0.7–2.8)
15	(1.0)	270	(18.6)	400	(27.6)	0.96	1.93	2.83	10–40	(0.7–2.8)
20	(1.4)	370	(25.5)	400	(27.6)	1.07	2.15	3.09	10–40	(0.7–2.8)
25	(1.7)	400	(27.6)	400	(27.6)	1.17	2.36	3.36	10–40	(0.7–2.8)
35	(2.4)	400	(27.6)	400	(27.6)	1.57	3.50	4.60	30–60	(2.1–4.1)
50	(3.4)	400	(27.6)	400	(27.6)	1.95	4.50	5.46	30–60	(2.1–4.1)
75	(5.2)	400	(27.6)	400	(27.6)	2.85	5.46	5.46	55–80	(3.8–5.5)
80	(5.5)	400	(27.6)	400	(27.6)	2.17	5.46	5.46	55–80	(3.8–5.5)
100	(6.9)	400	(27.6)	400	(27.6)	2.74	5.38	5.46	65–130	(4.5–8.9)

METRIC CONVERSION FACTOR: Cv / 1.16 - kv

TABLE 10 (Continued)
Cv – FLOW CAPACITY of 1000HP-1+6

OPT -12, 1-STEP REDUCED PORT – COMPOSITION DIAPHRAGM

$(F_L = 0.93)$

COMPOSITION DIAPHRAGM – SIZE – 1-1/2" (DN40) – 1-STEP REDUCED PORT										
Differential Pressure - ΔP_{Diff}		Max Inlet Pressure				Cv @ % DROOP			Range Spring	
		Metal Seated		Composition Seated						
psid	(Bard)	psig	(Barg)	psig	(Barg)	10%	20%	30%	psid	(Bard)
10	(0.7)	165	(11.4)	225	(15.5)	1.25	2.41	3.61	10–40	(0.7–2.8)
15	(1.0)	265	(18.3)	365	(25.2)	1.40	2.69	3.81	10–40	(0.7–2.8)
20	(1.4)	360	(24.8)	400	(27.6)	1.55	2.96	4.01	10–40	(0.7–2.8)
25	(1.7)	400	(27.6)	400	(27.6)	1.70	3.24	4.21	10–40	(0.7–2.8)
35	(2.4)	400	(27.6)	400	(27.6)	2.49	4.21	5.07	30–75	(2.1–5.2)
50	(3.4)	400	(27.6)	400	(27.6)	2.90	5.00	6.00	30–75	(2.1–5.2)
75	(5.2)	400	(27.6)	400	(27.6)	3.67	6.00	6.00	60–100	(4.1–6.9)
100	(6.9)	400	(27.6)	400	(27.6)	4.18	6.00	6.00	60–100	(4.1–6.9)

COMPOSITION DIAPHRAGM – SIZE – 2" (DN50) – 1-STEP REDUCED PORT										
Differential Pressure - ΔP_{Diff}		Max Inlet Pressure				Cv @ % DROOP			Range Spring	
		Metal Seated		Composition Seated						
psid	(Bard)	psig	(Barg)	psig	(Barg)	10%	20%	30%	psid	(Bard)
10	(0.7)	145	(10.0)	145	(10.0)	2.37	4.59	6.87	10–40	(0.7–2.8)
15	(1.0)	245	(16.9)	245	(16.9)	2.75	5.20	7.38	10–40	(0.7–2.8)
20	(1.4)	340	(23.4)	340	(23.4)	3.14	5.80	7.90	10–40	(0.7–2.8)
25	(1.7)	400	(27.6)	400	(27.6)	3.52	6.41	8.41	10–40	(0.7–2.8)
35	(2.4)	400	(27.6)	400	(27.6)	4.40	8.80	10.00	30–60	(2.1–4.1)
50	(3.4)	400	(27.6)	400	(27.6)	5.50	9.05	10.55	30–60	(2.1–4.1)
60	(4.1)	400	(27.6)	400	(27.6)	6.00	9.11	10.67	30–60	(2.1–4.1)
75	(5.2)	400	(27.6)	400	(27.6)	6.35	9.65	10.90	50–100	(3.4–6.9)
100	(6.9)	400	(27.6)	400	(27.6)	7.33	10.25	11.00	50–100	(3.4–6.9)

METRIC CONVERSION FACTOR: Cv / 1.16 - kv

TABLE 11
Cv – FLOW CAPACITY of 1000HP-1+6

FULL PORT – METAL DIAPHRAGM
($F_L = 0.93$)

METAL DIAPHRAGM – SIZE – 1/2" (DN15) – FULL PORT										
Differential Pressure - ΔP_{Diff}		Max Inlet Pressure				Cv @ % DROOP			Range Spring	
		Metal Seated		Composition Seated						
psid	(Bard)	psig	(Barg)	psig	(Barg)	10%	20%	30%	psid	(Bard)
10	(0.7)	215	(14.8)	215	(14.8)	0.42	0.81	1.18	10–50	(9.7–3.4)
15	(1.0)	335	(23.1)	335	(23.1)	0.47	0.89	1.27	10–50	(0.7–3.4)
20	(1.4)	400	(27.6)	400	(27.6)	0.53	0.98	1.37	10–50	(0.7–3.4)
25	(1.7)	400	(27.6)	400	(27.6)	0.58	1.04	1.45	10–50	(0.7–3.4)
35	(2.4)	400	(27.6)	400	(27.6)	0.67	1.18	1.62	10–50	(0.7–3.4)
50	(3.4)	400	(27.6)	400	(27.6)	0.88	1.52	2.01	40–100	(2.8–6.9)
75	(5.2)	400	(27.6)	400	(27.6)	1.03	1.78	2.34	40–100	(2.8–6.9)
100	(6.9)	400	(27.6)	400	(27.6)	1.18	2.04	2.67	40–100	(2.8–6.9)

METAL DIAPHRAGM – SIZE – 3/4" (DN20) – FULL PORT										
Differential Pressure - ΔP_{Diff}		Max Inlet Pressure				Cv @ % DROOP			Range Spring	
		Metal Seated		Composition Seated						
psid	(Bard)	psig	(Barg)	psig	(Barg)	10%	20%	30%	psid	(Bard)
10	(0.7)	160	(11.0)	160	(11.0)	0.70	1.36	2.07	10–40	(0.7–2.8)
15	(1.0)	250	(17.2)	250	(17.2)	0.76	1.50	2.20	10–40	(0.7–2.8)
20	(1.4)	340	(23.4)	340	(23.4)	0.82	1.65	2.34	10–40	(0.7–2.8)
25	(1.7)	400	(27.6)	400	(27.6)	0.88	1.77	2.44	10–40	(0.7–2.8)
35	(2.4)	400	(27.6)	400	(27.6)	1.00	2.01	2.65	30–60	(2.1–4.1)
50	(3.4)	400	(27.6)	400	(27.6)	1.33	2.66	3.47	30–60	(2.1–4.1)
75	(5.2)	400	(27.6)	400	(27.6)	1.93	3.32	4.43	50–90	(3.4–6.2)
90	(6.2)	400	(27.6)	400	(27.6)	2.29	3.71	5.00	50–90	(3.4–6.2)
100	(6.9)	400	(27.6)	400	(27.6)	2.56	4.18	5.00	70–100	(4.8–6.9)

METAL DIAPHRAGM – SIZE – 1" (DN25) – FULL PORT										
Differential Pressure - ΔP_{Diff}		Max Inlet Pressure				Cv @ % DROOP			Range Spring	
		Metal Seated		Composition Seated						
psid	(Bard)	psig	(Barg)	psig	(Barg)	10%	20%	30%	psid	(Bard)
10	(0.7)	145	(10.0)	145	(10.0)	0.78	1.55	2.42	10–40	(0.7–2.8)
15	(1.0)	220	(15.2)	220	(15.2)	0.87	2.10	2.67	10–40	(0.7–2.8)
20	(1.4)	300	(20.7)	300	(20.7)	0.96	1.92	2.93	10–40	(0.7–2.8)
25	(1.7)	375	(25.9)	375	(25.9)	1.04	2.13	3.13	10–40	(0.7–2.8)
35	(2.4)	400	(27.6)	400	(27.6)	1.21	2.54	3.53	30–60	(2.1–4.1)
50	(3.4)	400	(27.6)	400	(27.6)	1.67	3.47	4.62	30–60	(2.1–4.1)
75	(5.2)	400	(27.6)	400	(27.6)	2.25	4.79	6.00	55–80	(3.8–5.5)
80	(5.5)	400	(27.7)	400	(27.6)	2.37	5.05	6.00	55–80	(3.8–5.5)
100	(6.9)	400	(27.6)	400	(27.6)	3.03	5.20	6.00	65–100	(4.5–6.9)

FLOW CAPACITY of 1000HP-1+8 = (1000HP-1+6 Capacity) x .8

METRIC CONVERSION FACTOR: Cv / 1.16 - kv

TABLE 11 (Continued)
Cv – FLOW CAPACITY of 1000HP-1+6

FULL PORT – METAL DIAPHRAGM

$(F_L = 0.93)$

METAL DIAPHRAGM – SIZE – 1-1/4" (DN32) – FULL PORT										
Differential Pressure - ΔP_{Diff}		Max Inlet Pressure				Cv @ % DROOP			Range Spring	
		Metal Seated		Composition Seated						
psid	(Bard)	psig	(Barg)	psig	(Barg)	10%	20%	30%	psid	(Bard)
10	(0.7)	115	(7.9)	115	(7.9)	1.30	2.80	4.40	10–40	(0.7–2.8)
15	(1.0)	180	(12.4)	180	(12.4)	1.47	3.18	4.87	10–40	(0.7–2.8)
20	(1.4)	240	(16.6)	240	(16.6)	1.64	3.55	5.34	10–40	(0.7–2.8)
25	(1.7)	300	(20.7)	300	(20.7)	1.81	3.93	5.81	10–40	(0.7–2.8)
35	(2.4)	370	(25.5)	370	(25.5)	2.35	6.13	8.30	30–50	(2.1–3.4)
50	(3.4)	400	(27.6)	400	(27.6)	4.55	8.60	9.00	40–60	(2.8–4.1)
75	(5.2)	400	(27.6)	400	(27.6)	5.30	8.92	9.00	50–90	(3.4–6.2)
90	(6.2)	400	(27.6)	400	(27.6)	6.25	9.00	9.00	50–90	(3.4–6.2)
100	(6.9)	400	(27.6)	400	(27.6)	6.80	9.00	9.00	70–100	(4.8–6.9)

METAL DIAPHRAGM – SIZE – 1-1/2" (DN40) – FULL PORT										
Differential Pressure - ΔP_{Diff}		Max Inlet Pressure				Cv @ % DROOP			Range Spring	
		Metal Seated		Composition Seated						
psid	(Bard)	psig	(Barg)	psig	(Barg)	10%	20%	30%	psid	(Bard)
10	(0.7)	115	(7.9)	115	(7.9)	1.75	3.27	4.82	10–40	(0.7–2.8)
15	(1.0)	190	(13.1)	190	(13.1)	2.04	3.79	5.42	10–40	(0.7–2.8)
20	(1.4)	260	(17.9)	260	(17.9)	2.33	4.30	6.01	10–40	(0.7–2.8)
25	(1.7)	330	(22.8)	330	(22.8)	2.62	4.82	6.61	10–40	(0.7–2.8)
35	(2.4)	400	(27.6)	400	(27.6)	3.75	6.53	8.70	30–75	(2.1–5.2)
50	(3.4)	400	(27.6)	400	(27.6)	4.15	7.15	9.10	30–75	(2.1–5.2)
75	(5.2)	400	(27.6)	400	(27.6)	5.30	8.75	10.30	60–100	(4.1–6.9)
100	(6.9)	400	(27.6)	400	(27.6)	5.80	9.20	10.60	60–100	(4.1–6.9)

METAL DIAPHRAGM – SIZE – 2" (DN50) – FULL PORT										
Differential Pressure - ΔP_{Diff}		Max Inlet Pressure				Cv @ % DROOP			Range Spring	
		Metal Seated		Composition Seated						
psid	(Bard)	psig	(Barg)	psig	(Barg)	10%	20%	30%	psid	(Bard)
10	(0.7)	165	(11.4)	165	(11.4)	2.10	4.27	6.55	10–40	(0.7–2.8)
15	(1.0)	270	(18.6)	270	(18.6)	2.26	4.58	6.90	10–40	(0.7–2.8)
20	(1.4)	370	(25.5)	370	(25.5)	2.42	4.90	7.25	10–40	(0.7–2.8)
25	(1.7)	400	(27.6)	400	(27.6)	2.59	5.21	7.60	10–40	(0.7–2.8)
35	(2.4)	400	(27.6)	400	(27.6)	5.55	9.60	11.30	30–60	(2.1–4.1)
50	(3.4)	400	(27.6)	400	(27.6)	6.85	10.35	12.00	30–60	(2.1–4.1)
60	(4.1)	400	(27.6)	400	(27.6)	7.70	10.85	12.45	30–60	(2.1–4.1)
75	(5.2)	400	(27.6)	400	(27.6)	5.87	9.70	11.40	50–100	(3.4–6.9)
100	(6.9)	400	(27.6)	400	(27.6)	6.48	10.03	11.73	50–100	(3.4–6.9)

FLOW CAPACITY of 1000HP-1+8 = (1000HP-1+6 Capacity) x .8

METRIC CONVERSION FACTOR: Cv / 1.16 - kv

TABLE 12
Cv – FLOW CAPACITY of 1000HP-1+6

OPT -12, 1-STEP REDUCED PORT – METAL DIAPHRAGM

(F_L = 0.93)

METAL DIAPHRAGM – SIZE – 1/2" (DN15) – 1-STEP REDUCED PORT										
Differential Pressure - ΔP_{Diff}		Max Inlet Pressure				Cv @ % DROOP			Range Spring	
		Metal Seated		Composition Seated						
psid	(Bard)	psig	(Barg)	psig	(Barg)	10%	20%	30%	psid	(Bard)
10	(0.7)	270	(18.6)	300	(20.7)	0.23	0.57	0.87	10–50	(0.7–3.4)
15	(1.0)	400	(27.6)	400	(27.6)	0.27	0.59	0.95	10–50	(0.7–3.4)
20	(1.4)	400	(27.6)	400	(27.6)	0.31	0.61	1.03	10–50	(0.7–3.4)
25	(1.7)	400	(27.6)	400	(27.6)	0.36	0.63	1.12	10–50	(0.7–3.4)
35	(2.4)	400	(27.6)	400	(27.6)	0.44	0.66	1.28	10–50	(0.7–3.4)
50	(3.4)	400	(27.6)	400	(27.6)	0.63	1.21	1.67	40–100	(2.8–6.9)
75	(5.2)	400	(27.6)	400	(27.6)	0.83	1.52	2.03	40–100	(2.8–6.9)
100	(6.9)	400	(27.6)	400	(27.6)	0.96	1.73	2.27	40–100	(2.8–6.9)

METAL DIAPHRAGM – SIZE – 3/4" (DN20) – 1-STEP REDUCED PORT										
Differential Pressure - ΔP_{Diff}		Max Inlet Pressure				Cv @ % DROOP			Range Spring	
		Metal Seated		Composition Seated						
psid	(Bard)	psig	(Barg)	psig	(Barg)	10%	20%	30%	psid	(Bard)
10	(0.7)	190	(13.1)	325	(22.4)	0.42	0.81	1.18	10–40	(0.7–2.8)
15	(1.0)	295	(20.3)	415	(28.6)	0.47	0.89	1.27	10–40	(0.7–2.8)
20	(1.4)	395	(27.2)	400	(27.6)	0.53	0.98	1.37	10–40	(0.7–2.8)
25	(1.7)	400	(27.6)	400	(27.6)	0.58	1.04	1.45	10–40	(0.7–2.8)
35	(2.4)	400	(27.6)	400	(27.6)	0.67	1.18	1.62	30–60	(2.1–4.1)
50	(3.4)	400	(27.6)	400	(27.6)	0.88	1.52	2.01	30–60	(2.1–4.1)
75	(5.2)	400	(27.6)	400	(27.6)	1.03	1.78	2.34	50–90	(3.4–6.2)
90	(6.2)	400	(27.6)	400	(27.6)	1.10	1.85	2.48	50–90	(3.4–6.2)
100	(6.9)	400	(27.6)	400	(27.6)	1.59	2.58	3.50	70–100	(4.8–6.9)

METAL DIAPHRAGM – SIZE – 1" (DN25) – 1-STEP REDUCED PORT										
Differential Pressure - ΔP_{Diff}		Max Inlet Pressure				Cv @ % DROOP			Range Spring	
		Metal Seated		Composition Seated						
psid	(Bard)	psig	(Barg)	psig	(Barg)	10%	20%	30%	psid	(Bard)
10	(0.7)	190	(13.1)	280	(19.3)	0.51	1.05	1.55	10–40	(0.7–2.8)
15	(1.0)	290	(20.0)	400	(27.6)	0.57	1.17	1.74	10–40	(0.7–2.8)
20	(1.4)	395	(27.2)	400	(27.6)	0.63	1.29	1.93	10–40	(0.7–2.8)
25	(1.7)	400	(27.6)	400	(27.6)	0.68	1.29	1.93	10–40	(0.7–2.8)
35	(2.4)	400	(27.6)	400	(27.6)	0.68	1.40	2.13	30–60	(2.1–4.1)
50	(3.4)	400	(27.6)	400	(27.6)	0.92	1.90	3.10	30–60	(2.1–4.1)
75	(5.2)	400	(27.6)	400	(27.6)	1.13	2.41	4.02	55–80	(3.8–5.5)
80	(5.5)	400	(27.6)	400	(27.6)	1.16	2.48	4.15	55–80	(3.8–5.5)
100	(6.9)	400	(27.6)	400	(27.6)	1.75	4.08	5.46	65–100	(4.5–6.9)

FLOW CAPACITY of 1000HP-1+8 = (1000HP-1+6 Capacity) x .8
METRIC CONVERSION FACTOR: Cv / 1.16 - kv

TABLE 12 (Continued)
Cv – FLOW CAPACITY of 1000HP-1+6

OPT -12, 1-STEP REDUCED PORT – METAL DIAPHRAGM

$(F_L = 0.93)$

METAL DIAPHRAGM – SIZE – 1-1/2" (DN40) – 1-STEP REDUCED PORT										
Differential Pressure - ΔP_{Diff}		Max Inlet Pressure				Cv @ % DROOP			Range Spring	
		Metal Seated		Composition Seated						
psid	(Bard)	psig	(Barg)	psig	(Barg)	10%	20%	30%	psid	(Bard)
10	(0.7)	185	(12.8)	255	(17.6)	0.78	1.55	2.42	10–40	(0.7–2.8)
15	(1.0)	285	(19.7)	300	(20.7)	0.87	2.10	2.67	10–40	(0.7–2.8)
20	(1.4)	385	(26.6)	400	(27.6)	0.96	1.92	2.93	10–40	(0.7–2.8)
25	(1.7)	390	(26.9)	400	(27.6)	1.04	2.13	3.13	10–40	(0.7–2.8)
35	(2.4)	400	(27.6)	400	(27.6)	1.21	2.54	3.53	30–75	(2.1–5.2)
50	(3.4)	400	(27.6)	400	(27.6)	1.67	3.47	4.62	30–75	(2.1–5.2)
75	(5.2)	400	(27.6)	400	(27.6)	2.25	4.79	6.00	60–100	(4.1–6.9)
100	(6.9)	400	(27.6)	400	(27.6)	2.64	5.68	6.00	60–100	(4.1–6.9)

METAL DIAPHRAGM – SIZE – 2" (DN50) – 1-STEP REDUCED PORT										
Differential Pressure - ΔP_{Diff}		Max Inlet Pressure				Cv @ % DROOP			Range Spring	
		Metal Seated		Composition Seated						
psid	(Bard)	psig	(Barg)	psig	(Barg)	10%	20%	30%	psid	(Bard)
10	(0.7)	165	(11.4)	165	(11.4)	1.75	3.27	4.82	10–40	(0.7–2.8)
15	(1.0)	265	(18.3)	265	(18.3)	2.04	3.79	5.42	10–40	(0.7–2.8)
20	(1.4)	365	(25.2)	365	(25.2)	2.33	4.30	6.01	10–40	(0.7–2.8)
25	(1.7)	400	(27.6)	400	(27.6)	2.62	4.82	6.61	10–40	(0.7–2.8)
35	(2.4)	400	(27.6)	400	(27.6)	3.75	6.53	8.70	30–60	(2.1–4.1)
50	(3.4)	400	(27.6)	400	(27.6)	4.15	7.15	9.10	30–60	(2.1–4.1)
60	(4.1)	400	(27.6)	400	(27.6)	4.33	7.43	9.28	30–60	(2.1–4.1)
75	(5.2)	400	(27.6)	400	(27.6)	5.30	8.75	10.30	50–100	(3.4–6.9)
100	(5.9)	400	(27.6)	400	(27.6)	6.10	9.40	10.75	50–100	(3.4–6.9)

FLOW CAPACITY of 1000HP-1+8 = (1000HP-1+6 Capacity) x .8

TABLE 13
MAX Cv – MAX FLOW CAPACITY OF 1000HP-1+6
AS PRESSURE LOADED REGULATOR *

Body Size		Maximum Cv - Diaphragm			
		Composition		Metal	
In.	(DN)	Full Port	Reduced Port	Full Port	Reduced Port
1/2"	(15)	2.80	2.00	2.15	1.80
3/4"	(20)	4.00	2.80	4.00	1.95
1"	(25)	4.80	4.35	4.80	3.30
1-1/4"	(32)	6.40	N/A	8.72	N/A
1-1/2"	(40)	8.80	4.80	8.80	4.80
2"	(50)	10.40	8.50	9.95	7.40

* A pressure loaded regulator is defined herein as a differential regulator that uses a minimum of spring force and a maximum of loading pressure to generate the P2 outlet pressure. By minimizing spring force, the droop is kept to a minimum. See page 5. TABLE 13 values are based on a 25% droop value for calculation purposes.

METRIC CONVERSION FACTOR: Cv / 1.16 - kv

**TABLE 14
CONSOLIDATED PRESSURE vs. TEMPERATURE MATERIALS OPERATING LIMITS,
INCLUDING TRIM AND OPTION LIMITS**

Materials	End Conn. Option No.	Trim Design. No.	Inlet Pressure		Outlet Pressure ¹		Inlet & Outlet Temperature Rg.		Limiting Portion
			psig	(Barg)	psig	(Barg)	°F	(°C)	
BRZ / DI / BR DI / DI / BR	Std - NPT, Opt-31	BB, B2, B3	400	(27.6)	300	(20.7)	-20 to +180	(-29 to +83)	BC, NBR, Operation
		B1	400	(27.6)	300	(20.7)	-20 to +150	(-29 to +66)	Operation, BRZ, BR
			385	(26.5)	300	(20.7)	+200	(+94)	
			365	(25.2)	300	(20.7)	+250	(+121)	
			335	(23.1)	300	(20.7)	+300	(+149)	BRZ, BR,
			300	(20.7)	300	(20.7)	+350	(+177)	
		250	(17.2)	250	(17.2)	+400	(+205)		
		B5	400	(27.6)	300	(20.7)	+20 to +150	(-29 to +66)	Phos. Bronze
385	(26.5)		300	(20.7)	+200	(+94)			
DI / DI / SST CS / DI / SST	Std - NPT, Opt-31, Opt-32	S2N, S3, S40, SB	400	(27.6)	300	(20.7)	-20 to +180	(-29 to +83)	BC, NBR, Operation
		S1, S2, S5, S36	400	(27.6)	300	(20.7)	-20 to +400	(-29 to +205)	DI, TFE, FKM Operation
CS / CS / SST	Std - NPT, Opt-31, Opt-32.	S2N, S3, S40, SB	400	(27.6)	300	(20.7)	-20 to +180	(-29 to +83)	BC, NBR, Operation
		S1, S2, S5, S36	400	(27.6)	300	(20.7)	-20 to +400	(-29 to +205)	TFE, FKM, Operation
CS / DI / SST CS / CS / SST	Opt-30, 150# Flg.	S2N, S3, S40, SB	285	(19.7)	285	(19.7)	-20 to +100	(-29 to +38)	150# Flg.
			265	(18.3)	265	(18.3)	+180	(+83)	150# Flg., BC, NBR
		S1, S2, S5, S36	285	(19.7)	285	(19.7)	-20 to +100	(-29 to +38)	150# Flg.
			260	(17.9)	260	(17.9)	+200	(+94)	TFE, FKM, 150# Flg,
			230	(15.9)	230	(15.9)	+300	(+149)	
200	(13.8)	200	(13.8)	+400	(+205)				
CS / DI / SST CS / CS / SST	Opt-30, 300# Flg.,	S2N, S3, S40	400	(27.6)	300	(20.7)	-20 to +180	(-29 to +83)	BC, Operation
		S1, S2, S36	400	(27.6)	300	(20.7)	-20 to +400	(-29 to +205)	TFE, Operation

¹ Outlet pressure is the same spring setting for differential pressure and loading pressure. Indicated outlet pressure limits are those to contain overpressure conditions; such overpressure may cause diaphragm damage. It is recommended that pressure safety devices – safety relief valve or rupture disc – have their setpoint relief pressures at 110% of the UVRS (UVRS = “Upper Value of Range Spring”), plus the maximum loading pressure. Example: For a 10–40 psid (0.7–2.8 Barg) range spring and a P_{Load Max} = 100 psig (6.9 Barg), the safety device should be set to relieve at 110% x (40 + 100) psig = 154 psig (10.6 Barg).

BC = Neoprene. NBR = Buna-N. FKM = Fluorocarbon Elastomer. TFE = Polytetrafluoroethylene.

DIMENSIONS & WEIGHTS

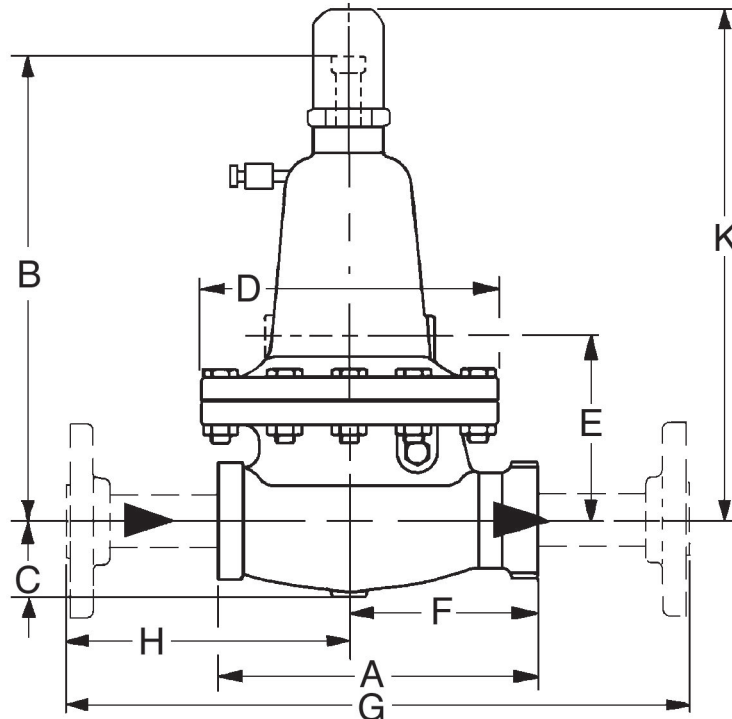

Regulator Size Inch	DIMENSIONS – ENGLISH (Inch)														Approx. Weight - lbs			
	A	-1+6	-1+8	C	D	-1+6	-1+8	F	G ¹	G ²	G ³	H ⁴	1+6	1+8	-1+6		-1+8	
		B	B			E	E						K	K	wo/ Flgs.	w/ Flgs.	wo/ Flgs.	w/ Flgs.
1/2"	5.94	10.00	10.50	1.62	5.62	3.75	4.25	3.94	10.75	11.00	13.94	5.38	11.62	12.13	18	22	21	28
3/4"	7.12	11.25	11.75	1.75	6.56	3.81	4.31	4.00	11.88	12.25	15.12	5.62	12.81	13.31	28	35	32	39
1"	7.94	11.75	12.25	2.12	7.38	4.38	4.88	4.69	13.62	14.00	15.94	6.75	13.44	13.94	37	46	42	51
1-1/4"	8.50	12.25	12.75	2.38	8.00	4.50	5.00	5.06	NA	NA	16.50	NA	14.19	14.69	48	N/A	54	N/A
1-1/2"	9.75	15.75	16.25	2.50	9.12	6.19	6.69	5.75	15.88	16.19	17.75	7.31	17.00	17.50	77	93	84	100
2"	11.25	16.00	16.50	2.88	11.25	7.06	7.50	6.62	19.31	19.62	19.22	9.81	17.38	17.88	109	131	120	142

Regulator Size (DN)	DIMENSIONS – METRIC (mm)														Approx. Weight - kgs			
	A	-1+6	-1+8	C	D	-1+6	-1+8	F	G ¹	G ²	G ³	H ⁴	1+6	1+8	1+6		1+8	
		B	B			E	E						K	K	wo/ Flgs.	w/ Flgs.	wo/ Flgs.	w/ Flgs.
(15)	151	254	267	41	143	95	108	100	273	279	354	137	295	308	8	11	10	13
(20)	181	286	299	44	167	97	110	102	302	311	384	143	325	338	13	16	15	18
(25)	202	298	311	54	187	111	124	119	346	356	405	171	341	354	17	21	19	23
(32)	216	311	324	60	203	114	127	129	NA	NA	419	NA	360	373	22	N/A	25	N/A
(40)	248	400	413	64	232	157	170	146	403	411	451	186	432	445	35	42	38	45
(50)	286	406	419	73	286	179	190	168	490	498	488	249	441	454	49	59	55	65

- 1 150# Flange - Also available with Opt-34, special 14" (356mm) face to face dimension - sizes 1/2" - 1" & 1-1/2" only.
- 2 300# Flange - Also available with Opt-34, special 14" (356mm) face to face dimension - sizes 1/2" - 1" & 1-1/2" only.
- 3 P.E. Pipe Nipples.
- 4 "H" dimension for 1-1/2" Size with Opt-34 is 6.13" (156mm).

The contents of this publication are presented for informational purposes only, and while every effort has been made to ensure their accuracy, they are not to be construed as warranties or guarantees, express or implied, regarding the products or services described herein or their use or applicability. We reserve the right to modify or improve the designs or specifications of such product at any time without notice.
 Cashco, Inc. does not assume responsibility for the selection, use or maintenance of any product. Responsibility for proper selection, use and maintenance of any Cashco, Inc. product remains solely with the purchaser.

MODEL 1000HP Differential PRODUCT CODER 02/07/20

An "X" in POS 12 followed by a 5-digit control number overrides remaining selections.

POS 1	B	POS 3	—	POS 5	—	POS 6 & 7	7	—	POS 10	POS 11	POS 12	POS 13	POS 14	POS 15	00B
-------	----------	-------	---	-------	---	-----------	----------	---	--------	--------	--------	--------	--------	--------	------------

POSITION 1 - MODEL		
Description	Options	CODE
Model 1000HP-1+6	-1+6	D
Model 1000HP-1+8	-1+8	E
All include closing cap.		

POSITION 3 - SIZE & SERVICE				
Size		Service		
		Gaseous	Liquid	Viscous (-27 Opt) *
In	(DN)	CODE	CODE	CODE
1/2"	(15)	4	J	R
3/4"	(20)	5	K	S
1"	(25)	6	L	T
1-1/4"	(32)	7	M	U
1-1/2"	(40)	8	N	V
2"	(50)	9	P	W

* Metal Seated B1,S1,S2,S2N,S5 or S40 Trim Only.

POSITION 5 - BODY & SPRING CHAMBER MATERIALS	
Body/Sp. Ch.	CODE
DI/DI	1
BRZ/DI *	2
CS/DI	4
CS/CS	5

* Note: BRZ Body Not Avail in 1-1/4" (DN32)

POSITION 6 & 7 - TRIM DESIGNATION			
Brass Trim		Stainless Steel Trim	
Desig.	CODE	Desig.	CODE
B1	B1	S1	S1
B2	B2 *		
B3	B3 *	S2	S2
B5	B5	S2N	SN *
BB	BB *		
BK	BK*	S3	S3 *
		S3N	SC *
		S5	S5 *
		S36	36 *
		S40	40 *
		S40V	4V*
		SB	SB *

* Not Available on -1+8.

POSITION 10 - END CONNECTIONS	
Description	CODE
NPT - Screwed	1
-30 Opt. - 150 LB RF Flgs. * ** (Std)	6
-30 Opt. - 300 LB RF Flgs. * ** (Std)	7
-31 Opt. - BSPT Tapered Thread	B
-31P Opt. - BSPP Parallel Thread	P
-32 Opt. - SCH. 80 PE Ext. Nipples*	E
-34 Opt. - 150 LB RF Flgs. 14" F to F Dimension (Sizes 1/2 -1" & 1-1/2" only) *	V
-34 Opt. - 300 LB RF Flgs. 14" F to F Dimension (Sizes 1/2 -1" & 1-1/2" only)*	W

*Nipples & flanges of same material as body. CS bodies use SST trim only.
** Not Available in 1-1/4" (DN32)

POSITION 11 - RANGE SPRINGS					
Size	psid	CODE	Size	psid	CODE
1/2" (DN15)	10-50	1	1-1/4" (DN32)	10-40	2
	40-100	4		30-50	5
3/4" (DN20)	10-40	2		40-60	N
	30-60	3		50-90	8
	50-90	8		70-100	L
1" (DN25)	70-110	C		1-1/2" (DN40)	10-40
	10-40	2	30-75		6
	30-60	3	60-100	A	
	50-70	9	2" (DN50)	10-40	2
	55-80	D		30-60	3
	65-100	H	50-100	E	

POSITION 12 - TRIM VARIATIONS			W/ -17 OPTION	
Description	Option	CODE	Option	CODE
No Special Trim Variation	--	0	--	--
Reduced Orifice (One-Step) Not Available on 1-1/4"	-12	A	-12+17	1
Integral Seat Surface (Not available with B1 Trim)	-14	C	-14+17	3
Stellited Seat Surface Integral Seat - S1 Trim Only	-15 *	D	-15+17 *	4
Reduced Orifice & Integral Seat See above for limitations	-12+14	E	-12+14+17	5
Reduced Orifice & Stellited Seat See above for limitations	-12+15 *	F	-12+15+17 *	6
Piston Spring Not Available on 2"	-17	H	--	--
For Special Construction Contact Cashco for Special Product Code.	SPQ		X	

* Includes Opt-14 Integral Seat.

POSITION 13 - FEATURE OPTIONS		
Description	Option	CODE
No Option	-	0
Spring Chamber Bleeder Plug.	BP	Z

POSITION 14 - SPRING CHAMBER OPTIONS		
Description	Option	CODE
No Option	-	0
DBL 1/2" Tapped CS Sp. Cham. on 1/2" & 3/4" Size.	-65	N
DBL 3/4" Tapped CS Sp. Cham. on 1" Size.	-65	P
DBL 1" Tapped CS Sp. Cham. on 1-1/4" & 1-1/2" Size.	-65	R
DBL 1-1/4" Tapped CS Sp. Cham. on 2" Size .	-65	S

POSITION 15 - BODY OPTIONS		
Description	Option	CODE
No Option	-	0
1/4" (DN8) NPT Drain Hole/Press. Tap.	-26	F

Алматы (7273)495-231
Ангарск (3955)60-70-56
Архангельск (8182)63-90-72
Астрахань (8512)99-46-04
Барнаул (3852)73-04-60
Белгород (4722)40-23-64
Белговецк (4162)22-76-07
Брянск (4832)59-03-52
Владивосток (423)249-28-31
Владикавказ (8672)28-90-48
Владимир (4922)49-43-18
Волгоград (844)278-03-48
Вологда (8172)26-41-59
Воронеж (473)204-51-73
Екатеринбург (343)384-55-89

Иваново (4932)77-34-06
Ижевск (3412)26-03-58
Иркутск (395)279-98-46
Казань (843)206-01-48
Калининград (4012)72-03-81
Калуга (4842)92-23-67
Кемерово (3842)65-04-62
Киров (8332)68-02-04
Коломна (4966)23-41-49
Кострома (4942)77-07-48
Краснодар (861)203-40-90
Красноярск (391)204-63-61
Курск (4712)77-13-04
Курган (3522)50-90-47
Липецк (4742)52-20-81

Магнитогорск (3519)55-03-13
Москва (495)268-04-70
Мурманск (8152)59-64-93
Набережные Челны (8552)20-53-41
Нижегород (831)429-08-12
Новокузнецк (3843)20-46-81
Ноябрьск (3496)41-32-12
Новосибирск (383)227-86-73
Омск (3812)21-46-40
Орел (4862)44-53-42
Оренбург (3532)37-68-04
Пенза (8412)22-31-16
Петрозаводск (8142)55-98-37
Псков (8112)59-10-37
Пермь (342)205-81-47

Ростов-на-Дону (863)308-18-15
Рязань (4912)46-61-64
Самара (846)206-03-16
Санкт-Петербург (812)309-46-40
Саратов (845)249-38-78
Севастополь (8692)22-31-93
Саранск (8342)22-96-24
Симферополь (3652)67-13-56
Смоленск (4812)29-41-54
Сочи (862)225-72-31
Ставрополь (8652)20-65-13
Сургут (3462)77-98-35
Сыктывкар (8212)25-95-17
Тамбов (4752)50-40-97
Тверь (4822)63-31-35

Тольятти (8482)63-91-07
Томск (3822)98-41-53
Тула (4872)33-79-87
Тюмень (3452)66-21-18
Ульяновск (8422)24-23-59
Улан-Удэ (3012)59-97-51
Уфа (347)229-48-12
Хабаровск (4212)92-98-04
Чебоксары (8352)28-53-07
Челябинск (351)202-03-61
Череповец (8202)49-02-64
Чита (3022)38-34-83
Якутск (4112)23-90-97
Ярославль (4852)69-52-93

Россия +7(495)268-04-70

Казахстан +7(7172)727-132

Киргизия +996(312)96-26-47

<https://cashco.nt-rt.ru/> || coc@nt-rt.ru