



ISO Registered Company

D-TB  
07-21

# MODEL D

## PRESSURE REDUCING REGULATOR

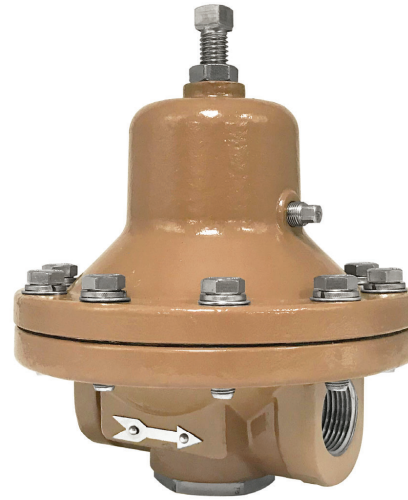

MODEL D

### OVERVIEW

The Model D is a pressure reducing regulator used in a broad range of service applications including gasses, liquids, cryogenics, and steam. This regulator handles inlet pressures up to 740 psig (51 Barg) and outlet pressures up to 630 psig (43.4 Barg) in multiple spring ranges.

### FEATURES

- Configurations:** Available in four different product configurations – general, dome loaded (Opt.-20), cryogenic service, food and pharmaceutical (Opt. -37).
- Versatile:** Four body materials and thirty-one trim material combinations to select from.
- Tight Shutoff:** Composition seats of PTFE, NBR, EPR, or FKM.
- Capacity:** Handles mid-range flow rates on a line size basis.
- Pressure Drop:** Handles mid-range pressure drops while maintaining good stability. Optional piston stabilizer provides up to 350 psid (24.1 Bard) capability for gaseous service.



### LINE SIZES AVAILABLE

3/8" (DN10), 1/2" (DN15), 3/4" (DN20), and 1" (DN25).



### END CONNECTIONS

NPT, FLANGED, BSPT, BSPP, EXTENDED NIPPLES



### COMMON APPLICATIONS

GASSES, LIQUIDS, CRYOGENICS, AND STEAM



### DESIGN PRESSURE

INLET: UP TO 740 psig (51 Barg)  
OUTLET: UP TO 630 psig (43.4 Barg)

Алматы (7273)495-231  
Ангарск (3955)60-70-56  
Архангельск (8182)63-90-72  
Астрахань (8512)99-46-04  
Барнаул (3852)73-04-60  
Белгород (4722)40-23-64  
Благовещенск (4162)22-76-07  
Брянск (4832)59-03-52  
Владивосток (423)249-28-31  
Владикавказ (8672)28-90-48  
Владимир (4922)49-43-18  
Волгоград (844)278-03-48  
Вологда (8172)26-41-59  
Воронеж (473)204-51-73  
Екатеринбург (343)384-55-89

Иваново (4932)77-34-06  
Ижевск (3412)26-03-58  
Иркутск (395)279-98-46  
Казань (843)206-01-48  
Калининград (4012)72-03-81  
Калуга (4842)92-23-67  
Кемерово (3842)65-04-62  
Киров (8332)68-02-04  
Коломна (4966)23-41-49  
Кострома (4942)77-07-48  
Краснодар (861)203-40-90  
Красноярск (391)204-63-61  
Курск (4712)77-13-04  
Курган (3522)50-90-47  
Липецк (4742)52-20-81

Магнитогорск (3519)55-03-13  
Москва (495)268-04-70  
Мурманск (8152)59-64-93  
Набережные Челны (8552)20-53-41  
Нижний Новгород (831)429-08-12  
Новокузнецк (3843)20-46-81  
Ноябрьск (3496)41-32-12  
Новосибирск (383)227-86-73  
Омск (3812)21-46-40  
Орел (4862)44-53-42  
Оренбург (3532)37-68-04  
Пенза (8412)22-31-16  
Псков (8112)59-10-37  
Петрозаводск (8142)55-98-37  
Пермь (342)205-81-47

Ростов-на-Дону (863)308-18-15  
Рязань (4912)46-61-64  
Самара (846)206-03-16  
Санкт-Петербург (812)309-46-40  
Саратов (845)249-38-78  
Севастополь (8692)22-31-93  
Саранск (8342)22-96-24  
Симферополь (3652)67-13-56  
Смоленск (4812)29-41-54  
Сочи (862)225-72-31  
Ставрополь (8652)20-65-13  
Сургут (3462)77-98-35  
Сыктывкар (8212)25-95-17  
Тамбов (4752)50-40-97  
Тверь (4822)63-31-35

Тольятти (8482)63-91-07  
Томск (3822)98-41-53  
Тула (4872)33-79-87  
Тюмень (3452)66-21-18  
Ульяновск (8422)24-23-59  
Улан-Удэ (3012)59-97-51  
Уфа (347)229-48-12  
Хабаровск (4212)92-98-04  
Чебоксары (8352)28-53-07  
Челябинск (351)202-03-61  
Череповец (8202)49-02-64  
Чита (3022)38-34-83  
Якутск (4112)23-90-97  
Ярославль (4852)69-52-93

Россия +7(495)268-04-70

Казахстан +7(7172)727-132

Киргизия +996(312)96-26-47

## STANDARD/GENERAL SPECIFICATIONS

<b>Line Sizes:</b>	3/8" (DN10), 1/2" (DN15), 3/4" (DN20), and 1" (DN25).	<b>Ported Spring Chamber:</b>	Spring chamber port threaded 1/8" (DN6) NPT for use with vented plug or piping to a remote location. Removable vented plug included. Not suitable for capturing flammable or lethal media.
<b>End Connections:</b>	<p><u>NPT:</u> Female Pipe Threads</p> <p><u>Flanged:</u> Steel and stainless steel body materials only. Mates with ASME 150, ASME 300, or PN40 flanged end connections. 14" (356 mm) face to face dimension only. Not available in 3/8" (DN10) line size.</p> <p><u>Opt-31:</u> BSPT - Taper Thread.</p> <p><u>Opt-31P:</u> BSPP - Parallel Thread. Not available in 1" (DN25) size.</p> <p><u>Opt-32:</u> Extended Pipe Nipples.</p>	<b>Temperature:</b>	See Tables 1, 3, 4(a), and 4(b) for temperature limitations.
<b>Body/Spring Chamber/Material Combinations:</b>	<p>DI/DI, BRZ/DI, BRZ/BRZ, CS/DI, CS/CS, SST/DI, SST/CS, SST/SST, BRZ/BRZ (Opt-80), CS/BRZ (Opt-80), DI/BRZ (Opt-80), SST/BRZ (Opt-80)</p> <p>DI = Cast Ductile Iron ASTM A395 60-40-18</p> <p>CS = Cast Carbon Steel ASTM A216 WCB or ASTM A352 LCC</p> <p>SST = Cast Stainless Steel ASTM A351 CF8M</p> <p>BRZ = Cast Bronze ASTM B62 C83600</p>	<b>Outlet Pressure:</b>	<p><u>Standard:</u> 2-150 psig (0.14 - 10.3 Barg) in four range springs. See Table 2.</p> <p><u>Opt-80:</u> 100-250 psi (6.9-17.2 Bar) spring range. Bronze spring chamber material only.</p> <p><u>Opt-20:</u> Dome loaded - up to 210 psi (14.5 Bar).</p>
<b>Body Cap Materials:</b>	<p><u>Brass:</u> For use with bronze bodies. ASTM B16 C36000</p> <p><u>Stainless Steel:</u> For use with all other body materials. ASTM A479 316/316L</p>	<b>Pressure Drop:</b>	<p><u>Standard:</u> Up to 150 psid (10.3 Bard). Dependent on range spring selection; See Table 2.</p> <p><u>Opt-4:</u> Up to 350 psid (24.2 Bard), gaseous service only.</p> <p><u>Opt-20:</u> Up to 250 psid (17.2 Bard) See Table 2.</p>
<b>Inlet Design Pressure:</b>	Up to 740 psig (51 Barg). See Table 1 for pressure specifications.	<b>Trim Designs:</b>	Metal or composition seats with brass, Monel®, or stainless steel materials. Metal or composition diaphragms. See Tables 3, 4(a), and 4(b).
<b>Gaskets:</b>	<u>Standard:</u> PTFE gasket for use with metal diaphragms only. PTFE cylinder gasket. * See Table 3.	<b>Capacities:</b>	Up to 3.6 Cv. See Table 7 for Cv vs. outlet pressure vs. body size vs. diaphragm material.
<b>Range Springs:</b>	<p><u>Stainless Steel:</u> For use with bronze and stainless steel spring chambers.</p> <p><u>Epoxy Coated:</u> For use with Ductile Iron and Carbon Steel Spring Chambers.</p>	<b>Flow Tables:</b>	<p><u>Water</u> - Table 8.</p> <p><u>Compressed Air</u> - Table 9.</p> <p><u>Steam</u> - Table 10.</p>
<b>Flange Bolting:</b>	<u>Standard:</u> 304 Stainless Steel ASTM F593 Group 1	<b>Seat Leakage:</b>	See Table 6 for wide open capacities for use for safety relief sizing.
<b>Painting:</b>	<u>Standard:</u> All non-corrosion resistant body, spring chamber/cover dome materials are epoxy coated per Cashco specification S-1606.	<b>Spring Chamber Vented Plug:</b>	1/8" (DN6) NPT polyethylene vented plug to allow for spring chamber displacement. Not included on dome loaded (Opt-20) configuration. Stainless steel vented plug (Opt-25S) included with cryogenic and food/pharmaceutical service.

## OPTION SPECIFICATIONS

<b>Option -3:</b>	<u>HANDWHEEL &amp; LOCKING LEVER:</u> For use when outlet pressure setting changes are frequent.	<b>Option -37:</b>	<u>FOOD AND PHARMACEUTICAL:</u> Includes electropolished stainless steel body and spring chamber, NPT end connections, T-handle adjusting screw, and S1 or S6 trim designations only. Cleaned per Cashco specification S-1576. Adjustable outlet pressures up to 80 psig (5.5 Barg). Option-87 comes with inlet and outlet gauge taps and 1-1/2" (40 mm) diameter SST pressure gauge, 0-100 PSIG (0-6.9 Barg)
<b>Option -4:</b>	<u>PISTON STABILIZER:</u> Recommended for gaseous service only. Stabilizer provides added guiding to maximize stability for internal trim, allowing improved pressure drop capability. Stabilizer materials are stainless steel/PTFE. For use with all trim designation numbers. See Table 2 for application recommendations.	<b>Option -40:</b>	<u>CS NACE CONSTRUCTION:</u> Internal wetted portions meet NACE standard MR0175, when exterior of the regulator is not directly exposed to a sour gas environment, buried, insulated or otherwise denied direct atmospheric exposure. CS/CS body/spring chamber material with S40, S40T, and S40V only trim. (Alternate LCC body/spring chamber material with S40B and S40C only trim.) Available all sizes, except 3/8" (DN10).
<b>Option -5:</b>	<u>BRZ CRYOGENIC CONSTRUCTION:</u> BRZ/BRZ body/spring chamber materials. NPT end connections. BO, and B5 trim selections only. SST flange bolting and range spring; remaining parts of brass or bronze materials. TFE-silicate gaskets. 1/8" (DN6) NPT tapped spring chamber vent/purge connection. Drilled condensate drain hole near adjusting screw. Cleaned and packaged for oxygen service per Cashco cleaning specification #S-1134. Applicable temperature range -325° to +150° F (-198° to +66° C). <b>NOTE:</b> Design requires that spring chamber be mounted pointing downwards in a horizontal pipe. See Figure 3.	<b>Option -40SST:</b>	<u>SST NACE CONSTRUCTION:</u> Same as Opt-40, except uses SST/SST body/spring chamber construction.
<b>Option -20:</b>	<u>DOME LOADED:</u> No range spring. Use when the outlet pressure is frequently changed. Composition diaphragm only. Incorporates a bronze, carbon steel, or stainless steel loading chamber with 1/4" NPT loading connection for external pressure loading up to 210 psi (17.2 Bar).	<b>Option -55:</b>	<u>OXYGEN CLEANING:</u> Cleaning per Cashco specification S-1134 for oxygen service. Includes sealed enclosure bag and notification tag. Stainless steel or bronze body/spring chamber materials only.
<b>Option -25S:</b>	<u>STAINLESS STEEL VENTED PLUG:</u> 1/8" (DN6) NPT stainless steel vented plug to allow spring chamber displacement. Required for cryogenic and food/pharmaceutical service.	<b>Option -56:</b>	<u>NON-OXYGEN CLEANING:</u> Cleaning per Cashco specification S-1542. Cleaning identical to that of Opt-55, but not labeled nor suitable for oxygen service. For use with all body/spring chamber materials.
<b>Option -31:</b>	<u>BSPT END CONNECTIONS:</u> British Standard Pipe Taper threads per ISO 7-1.	<b>Option -80:</b>	<u>HIGH OUTLET PRESSURE:</u> Taller spring chamber to allow for 100-250 psi (6.9-17.2 Bar) spring range. For use with bronze spring chamber only.
<b>Option -31P:</b>	<u>BSPP END CONNECTIONS:</u> British Standard Pipe Parallel threads per ISO 7-1. Not available for 1" (DN25) line size.	<b>Option -87:</b>	<u>GAUGE PORTS:</u> Includes two 1/8" NPT (DN6) body taps. One located on the inlet, one on the outlet for gauge connections. Plugs included. Included with dome loaded configuration.
<b>Option -32:</b>	<u>PLAIN END EXTENDED NIPPLES:</u> Schedule 80 plain end extended pipe nipples available for carbon steel or stainless steel bodies. Not available on 3/8" (DN10) line size or with cryogenic construction.	<b>ATEX 2014/34/EU:</b>	Declaration of Conformity certificate and appropriate nameplate markings available. See Model D IOM for more details.
<b>Option -36:</b>	<u>SST CRYOGENIC CONSTRUCTION:</u> Same specifications as Option -5, <u>except:</u> For SST/SST body/spring chamber materials.	<b>PED 2014/68/EU:</b>	SEP (Sound Engineering Practice) statement of compliance certificate available per 2014/68/EU Article 4 Section 3.

# TECHNICAL SPECIFICATIONS

**TABLE 1  
MODEL D DESIGN PRESSURE VS. TEMPERATURE RATINGS  
RATINGS PER ASME B31.3**

End Connection	Materials of Construction (Body/Spring Chamber)	Design Conditions							
		Inlet				Outlet			
		Containment Pressure		Temperature		Containment Pressure		Temperature	
		PSIG	(Barg)	°F	(°C)	PSIG	(Barg)	°F	(°C)
NPT, BSPT, BSPP, & PE NIPPLES	DI/DI	740	(51.0)	-20 to +100	(-29 to +40)	630	(43.4)	-20 to +100	(-29 to +40)
		700	(48.2)	200	(93)	630	(43.4)	200	(93)
		660	(45.5)	300	(149)	580	(40.0)	300	(149)
		625	(43.1)	400	(204)	535	(36.8)	400	(204)
		585	(40.3)	500	(260)	505	(34.8)	500	(260)
		550	(37.9)	600	(316)	475	(32.7)	600	(316)
	BRZ/DI	740	(51.0)	-20 to +100	(-29 to +40)	630	(43.4)	-20 to +100	(-29 to +40)
		730	(50.3)	200	(93)	620	(42.7)	200	(93)
		640	(44.1)	300	(149)	545	(37.5)	300	(149)
		585	(40.3)	400	(200)	500	(34.4)	400	(200)
	BRZ/BRZ	740	(51.0)	-325 to +150	(-198 to +65)	630	(43.4)	-325 to +150	(-198 to +65)
		730	(50.3)	200	(93)	620	(42.7)	200	(93)
		680	(46.8)	250	(121)	580	(40.0)	250	(121)
		640	(44.1)	300	(149)	545	(37.5)	300	(149)
		610	(42.0)	350	(177)	520	(35.8)	350	(177)
		585	(40.3)	400	(200)	500	(34.4)	400	(200)
	CS/DI, CS/CS, SST/CS, & SST/DI	740	(51.0)	-20 to +200	(-29 to +93)	630	(43.4)	-20 to +200	(-29 to +93)
		740	(51.0)	300	(149)	580	(40.0)	300	(149)
		740	(51.0)	400	(204)	535	(36.8)	400	(204)
		740	(51.0)	500	(260)	505	(34.8)	500	(260)
		740	(51.0)	600	(316)	475	(32.7)	600	(316)
	SST/SST	740	(51.0)	-325 to +200	(-198 to +93)	630	(43.4)	-325 to +200	(-198 to +93)
		740	(51.0)	300	(149)	580	(40.0)	300	(149)
		740	(51.0)	400	(204)	535	(36.8)	400	(204)
		740	(51.0)	500	(260)	505	(34.8)	500	(260)
		740	(51.0)	600	(316)	475	(32.7)	600	(316)
	CS/BRZ	740	(51.0)	-20 to +150	(-29 to +65)	630	(43.4)	-20 to +150	(-29 to +65)
		740	(51.0)	200	(93)	620	(42.7)	200	(93)
		740	(51.0)	250	(121)	580	(40.0)	250	(121)
		740	(51.0)	300	(149)	545	(37.5)	300	(149)
		740	(51.0)	350	(177)	520	(35.8)	350	(177)
		740	(51.0)	400	(200)	500	(34.4)	400	(200)
	DI/BRZ	740	(51.0)	-20 to +100	(-29 to +40)	630	(43.4)	-20 to +100	(-29 to +40)
		700	(48.2)	200	(93)	620	(42.7)	200	(93)
		660	(45.5)	300	(149)	545	(37.5)	300	(149)
		625	(43.1)	400	(200)	500	(34.4)	400	(200)
SST/BRZ	740	(51.0)	-325 to +150	(-198 to +65)	630	(43.4)	-325 to +150	(-198 to +65)	
	740	(51.0)	200	(93)	620	(42.7)	200	(93)	
	740	(51.0)	250	(121)	580	(40.0)	250	(121)	
	740	(51.0)	300	(149)	545	(37.5)	300	(149)	
	740	(51.0)	350	(177)	520	(35.8)	350	(177)	
	740	(51.0)	400	(200)	500	(34.4)	400	(200)	

**NOTES:**

- 1.) CS can be either ASTM A216 WCB or ASTM A352 LCC. With properly selected materials, valves using ASTM A352 LCC have a minimum temperature rating of -50°F (-46°C).
- 2.) Pressure rating shall not exceed 375 psig (26 Barg) when body is stainless steel and process medium is oxygen. Temperature rating shall not exceed 400°F (200°C) for all above materials when the process medium is oxygen. (CGA G-4.4)

**TABLE 1 (Continued)**  
**MODEL D DESIGN PRESSURE VS. TEMPERATURE RATINGS**  
**RATINGS PER ASME B31.3**

End Connection	Materials of Construction (Body/Spring Chamber)	Design Conditions							
		Inlet				Outlet			
		Containment Pressure		Temperature		Containment Pressure		Temperature	
		PSIG	(Barg)	°F	(°C)	PSIG	(Barg)	°F	(°C)
Class 150 Flanged	CS/CS	285	(19.6)	-20 to +100	(-29 to +38)	285	(19.6)	-20 to +100	(-29 to +38)
		260	(17.9)	200	(93)	260	(17.9)	200	(93)
		230	(15.8)	300	(149)	230	(15.8)	300	(149)
		200	(13.7)	400	(204)	200	(13.7)	400	(204)
		170	(11.7)	500	(260)	170	(11.7)	500	(260)
		140	(9.6)	600	(316)	140	(9.6)	600	(316)
	SST/SST	275	(19.0)	-325 to +100	(-198 to +38)	275	(19.0)	-325 to +100	(-198 to +38)
		235	(16.2)	200	(93)	235	(16.2)	200	(93)
		215	(14.8)	300	(149)	215	(14.8)	300	(149)
		195	(13.4)	400	(204)	195	(13.4)	400	(204)
		170	(11.7)	500	(260)	170	(11.7)	500	(260)
		140	(9.6)	600	(316)	140	(9.6)	600	(316)
	CS/BRZ	285	(19.6)	-20 to +100	(-29 to +38)	285	(19.6)	-20 to +100	(-29 to +38)
		260	(17.9)	200	(93)	260	(17.9)	200	(93)
		230	(15.8)	300	(149)	230	(15.8)	300	(149)
		200	(13.7)	400	(204)	200	(13.7)	400	(204)
	SST/BRZ	275	(19.0)	-325 to +100	(-198 to +38)	275	(19.0)	-325 to +100	(-198 to +38)
		235	(16.2)	200	(93)	235	(16.2)	200	(93)
		215	(14.8)	300	(149)	215	(14.8)	300	(149)
		195	(13.4)	400	(204)	195	(13.4)	400	(204)
Class 300 Flanged	CS/CS	740	(51.0)	-20 to +100	(-29 to +38)	630	(43.4)	-20 to +100	(-29 to +38)
		680	(46.8)	200	(93)	630	(43.4)	200	(93)
		655	(45.1)	300	(149)	580	(40.0)	300	(149)
		635	(43.7)	400	(204)	535	(36.8)	400	(204)
		605	(41.7)	500	(260)	505	(34.8)	500	(260)
		570	(39.3)	600	(316)	475	(32.7)	600	(316)
	SST/SST	720	(49.6)	-325 to +100	(-198 to +38)	630	(43.4)	-325 to +100	(-198 to +38)
		620	(42.7)	200	(93)	620	(42.7)	200	(93)
		560	(38.6)	300	(149)	560	(38.6)	300	(149)
		515	(35.5)	400	(204)	515	(35.5)	400	(204)
		480	(33.1)	500	(260)	480	(33.1)	500	(260)
		450	(31.0)	600	(316)	450	(31.0)	600	(316)
	CS/BRZ	740	(51.0)	-20 to +100	(-29 to +38)	630	(43.4)	-20 to +100	(-29 to +38)
		680	(46.8)	200	(93)	620	(42.7)	200	(93)
		655	(45.1)	300	(149)	545	(37.5)	300	(149)
		635	(43.7)	400	(204)	500	(34.4)	400	(204)
	SST/BRZ	720	(49.6)	-325 to +100	(-198 to +38)	630	(43.4)	-325 to +100	(-198 to +38)
		620	(42.7)	200	(93)	620	(42.7)	200	(93)
		560	(38.6)	300	(149)	545	(37.5)	300	(149)
		515	(35.5)	400	(204)	500	(34.4)	400	(204)

**NOTES:**

- 1.) CS can be either ASTM A216 WCB or ASTM A352 LCC. With properly selected materials, valves using ASTM A352 LCC have a minimum temperature rating of -50°F (-46°C).
- 2.) Pressure rating shall not exceed 375 psig (26 Barg) when body is stainless steel and process medium is oxygen. Temperature rating shall not exceed 400°F (200°C) for all above materials when the process medium is oxygen. (CGA G-4.4)

**TABLE 1 (Continued)**  
**MODEL D DESIGN PRESSURE VS. TEMPERATURE RATINGS**  
**RATINGS PER ASME B31.3**

End Connection	Materials of Construction (Body/Spring Chamber)	Design Conditions							
		Inlet				Outlet			
		Containment Pressure		Temperature		Containment Pressure		Temperature	
		PSIG	(Barg)	°F	(°C)	PSIG	(Barg)	°F	(°C)
PN40 Flanged	CS/CS	580	(40.0)	-20 to +392	(-29 to +200)	580	(40.0)	-20 to +392	(-29 to +200)
		565	(38.2)	500	(260)	505	(34.8)	500	(260)
		490	(34.1)	600	(315)	475	(32.7)	600	(315)
	SST/SST	580	(40.0)	-325 to +300	(-198 to +149)	580	(40.0)	-325 to +300	(-198 to +149)
		535	(37.2)	400	(204)	535	(37.2)	400	(204)
		505	(35.0)	500	(260)	505	(35.0)	500	(260)
		480	(33.2)	600	(315)	475	(32.7)	600	(315)
	CS/BRZ	580	(40.0)	-20 to +250	(-29 to +121)	580	(40.0)	-20 to +250	(-29 to +121)
		580	(40.0)	302	(150)	545	(37.5)	300	(149)
		580	(40.0)	392	(200)	500	(34.4)	392	(200)
		575	(39.9)	400	(204)	500	(34.4)	400	(204)
	SST/BRZ	580	(40.0)	-325 to +250	(-198 to +121)	580	(40.0)	-325 to +250	(-198 to +121)
		580	(40.0)	300	(149)	545	(37.5)	300	(149)
		535	(37.2)	400	(204)	500	(34.4)	400	(204)
	NOTES:								
1.) CS can be either ASTM A216 WCB or ASTM A352 LCC. With properly selected materials, valves using ASTM A352 LCC have a minimum temperature rating of -50°F (-46°C).									
2.) Pressure rating shall not exceed 375 psig (26 Barg) when body is stainless steel and process medium is oxygen. Temperature rating shall not exceed 400°F (200°C) for all above materials when the process medium is oxygen. (CGA G-4.4)									

**TABLE 2  
RANGE SPRINGS WITH RECOMMENDED PRESSURE DROPS**

Construction	Range spring		Recommended Max Pressure Drop*	
	psig	(Barg)	psid	(Bard)
Standard or Cryogenic	2-15	(.14-1.0)	100	(6.9)
	10-40	(.69-2.8)	125	(8.6)
	30-80	(2.1-5.5)	150	(10.3)
	70-150	(4.8-10.3)		
Opt-80	100-250	(6.9-17.2)		
Opt-4 Piston Stabilizer	2-15	(.14-1.0)	200	(13.8)
	10-40	(.69-2.8)	350	(24.2)
	30-80	(2.1-5.5)		
	70-150	(4.8-10.3)		
Opt-4 and Opt-80	100-250	(6.9-17.2)		

**\*NOTES:**

- B0 and B1 trim: 100 psid max when used on steam service.
- Opt-4 piston stabilizer is recommended only for gaseous service with critical or "choked" flow. This occurs when P1abs/P2abs is greater than 2.0.

**TABLE 3  
BRASS TRIM MATERIAL**

PART	BRASS TRIM #							
	METAL SEAT		COMPOSITION SEAT					
	B0 <sup>1</sup>	B1	B2 (Air/H <sub>2</sub> O)	B4	B5 (Oxygen)	BB (Fuel-Oils)	BJ	BK
Diaphragm	Phos Brz	302 SST	BC	FKM	Phos Brz	NBR	FK	FKM
Diaphragm Gasket	PTFE	PTFE	None	None	PTFE	None	None	None
Cylinder	Brass	Brass	Brass	Brass	Brass	Brass	Brass	Brass
Cylinder Gasket	PTFE	PTFE	PTFE	PTFE	PTFE	PTFE	PTFE	PTFE
Piston	Brass	Brass	Brass	Brass	Brass	Brass	Brass	Brass
Seat Disc	None	None	NBR	PTFE	PTFE	NBR	PTFE	FKM
Piston Spring	302 SST	302 SST	Phos Brz	302 SST	Phos Brz	Phos Brz	Phos. Brz.	Phos. Brz.
Pusher Plate	Brass	Brass	Brass	Brass	Brass	Brass	Brass	Brass
Temperature Range	-325 to +200°F -198 to +93°C	-325 to +400°F -198 to +204°C	-20 to +200°F -29 to +93°C	0 to +400°F -18 to +204°C	-325 to +200°F -198 to +93°C	-20 to +200°F -29 to +93°C	-40 to +200°F -40 to +93°C	0 to +200°F -18 to +93°C
Max Loading Pressure	100 (psid) 6.9 (Bard)	250 (psid) 17.2 (Bard)	250 (psid) 17.2 (Bard)	250 (psid) 17.2 (Bard)	250 (psid) 17.2 (Bard)	250 (psid) 17.2 (Bard)	250 (psid) 17.2 (Bard)	250 (psid) 17.2 (Bard)

**NOTES:**

- B0 and B1 trim: 100 psid (6.9 Bard) max when used on steam service.
- Metal seated trim is not recommended on any service where the flow will be dead ended down stream of the pressure reducing regulator.

**= Most common use - See Table 5**

**TABLE 4(a)**  
**MONEL & STAINLESS STEEL TRIM MATERIAL – METAL SEAT**

PART	STAINLESS STEEL TRIM #							MONEL TRIM #
	S0	S1 <sup>1</sup>	S2 (Steam)	S2N	SG	S40 (NACE)	S40B (NACE)	M1
Diaphragm	TFE Coated 302 SST	302 SST	302 SST	BC	Gylon	BC	Low Temp BC	302 SST
Diaphragm Gasket	PTFE	PTFE	PTFE	None	None	None	None	PTFE
Cylinder	316 SST	316 SST	416 SST	416 SST	416 SST	316 SST	316SST	Monel
Cylinder Gasket	PTFE	PTFE	PTFE	PTFE	PTFE	PTFE	PTFE	PTFE
Piston	316 SST	316 SST	416 SST	416 SST	416 SST	316 SST	316SST	Monel
Piston Spring	302 SST	302 SST	302 SST	302 SST	302 SST	Inconel X-750	Inconel X-750	302 SST
Pusher Plate	316 SST	316 SST	316 SST	316 SST	Monel	316 SST	316SST	316 SST
Temperature Range	-325 to +400°F -198 to +204°C		-20 to +400°F -29 to +204°C	-20 to +200°F -29 to +93°C	-20 to +400°F -29 to +204°C	-20 to +200°F -29 to +93°C	-65 to +250°F -54 to +121°C	-325 to +400°F -198 to +204°C
Max Loading Pressure	250 (psid) 17.2 (Bard)	100 (psid) 6.9 (Bard)	250 (psid) 17.2 (Bard)	250 (psid) 17.2 (Bard)	250 (psid) 17.2 (Bard)	250 (psid) 17.2 (Bard)	250 (psid) 17.2 (Bard)	250 (psid) 17.2 (Bard)

**= Most common use - See Table 5**

**TABLE 4(b)**  
**MONEL & STAINLESS STEEL TRIM MATERIAL COMBINATION – COMPOSITION (SOFT) SEAT**

PART	STAINLESS STEEL TRIM #											MONEL TRIM #
	S3	S4	S4N (Air/H <sub>2</sub> O)	S6 (Hot Air/H <sub>2</sub> O)	S9	S36	S40T (NACE)	S40V (NACE)	S40C (NACE)	SB	SK	M36
Diaphragm	BC	BC	BC	EPDM	TFE Coated 302 SST	302 SST	FKM	FKM	Low Temp BC	NBR	FKM	302 SST
Diaphragm Gasket	None	None	None	None	PTFE	PTFE	None	None	None	None	None	PTFE
Cylinder	316 SST	416 SST	416 SST	316 SST	316 SST	316 SST	316 SST	316 SST	316 SST	416 SST	316 SST	Monel
Cylinder Gasket	PTFE	PTFE	PTFE	PTFE	PTFE	PTFE	PTFE	PTFE	PTFE	PTFE	PTFE	PTFE
Piston	316 SST	416 SST	416 SST	316 SST	316 SST	316 SST	316 SST	316 SST	316 SST	416 SST	316 SST	Monel
Seat Disc	PTFE	PTFE	NBR	EPR	PTFE	PTFE	PTFE	FKM	PTFE	NBR	FKM	PTFE
Piston Spring	302 SST	302 SST	302 SST	302 SST	302 SST	302 SST	Inconel X-750	Inconel X-750	Inconel X-750	302 SST	302 SST	302 SST
Pusher Plate	316 SST	316 SST	316 SST	316 SST	316 SST	316 SST	316 SST	316 SST	316 SST	316 SST	316 SST	316 SST
Temperature Range	-20 to +200°F -29 to +93°C		-60 to +300°F -51 to +149°C	-325 to +400°F -198 to +204°C	0 to +400°F -18 to +204°C		-65 to +250°F -54 to +121°C	-20 to +200°F -29 to +93°C	0 to +400°F -18 to +204°C	-325 to +400°F -198 to +204°C		
Max Loading Pressure	250 (psid) 17.2 (Bard)	250 (psid) 17.2 (Bard)	250 (psid) 17.2 (Bard)	250 (psid) 17.2 (Bard)	250 (psid) 17.2 (Bard)	250 (psid) 17.2 (Bard)	250 (psid) 17.2 (Bard)	250 (psid) 17.2 (Bard)	250 (psid) 17.2 (Bard)	250 (psid) 17.2 (Bard)	250 (psid) 17.2 (Bard)	250 (psid) 17.2 (Bard)

**= Most common use - See Table 5**

**ABBREVIATIONS**

NBR = Buna-N    BC = Neoprene    EPDM = Ethylene Propylene Diene    EPR = Ethylene Propylene    TFE = Polytetrafluoroethylene  
FK = Fluorosilicone    FKM = Fluorocarbon elastomer    Phos BRZ = Phosphor Bronze

**TABLE 5  
APPLICATIONS**

FLUID	RECOMMENDED CONSTRUCTION	TRIM DESIGNATION #
Air or Inert Gases	Composition Seat and Diaphragm Metal Seat and Composition Diaphragm Metal Seat and Diaphragm	<b>B2, B4, SB, S4N</b> S2N B0, B1
Oxygen	Composition Seat and Diaphragm Composition Seat and Metal Diaphragm Metal Seat and Diaphragm	B4, BJ, BK, SK <b>B5, S36</b> S1
Oxygen above 290 psid	Metal Seat and Diaphragm TFE Seat and Metal Diaphragm	M1 M36
Chemicals	Metal Seat and Diaphragm Metal Seat and Composition Diaphragm Composition Seat and Diaphragm TFE seat and Metal Diaphragm	S1, S2, S0 S40 SB, S3, S4, SK, S4N, S6 or S40T, S9
Sour Gas	Metal Seat and Composition Diaphragm Composition Seat and Diaphragm	S40, S40B S40T, S40V, S40C
Cryogenic Gas or Liquids	TFE Seat and Metal Diaphragm Metal Seat and Diaphragm	<b>B5 or S36</b> B0 or S1
Fuel Oil	Composition Seat and Diaphragm	<b>BB, BK, B4, SB, SK, S3, S4, or S4N</b>
Hydrocarbon Gas or Liquids	Composition Seat and Diaphragm	BB, BK, B4, SK, S3, S4, or S4N
Saturated Steam, Low Pressures - up to 50 psig (3.4 Barg)	Metal Seat and Diaphragm Metal Seat and Composition Diaphragm Composition Seat and Diaphragm	<b>S2, B0, or S1</b> SG S6
Saturated Steam Pressures up to 100 psig (6.8 Barg) 50 psid (3.4 Barg)	Metal Seat and Diaphragm Metal Seat and Composition Diaphragm	<b>S2, B0, B1 or S1</b> SG
Steam Pressures above 100 psig (6.9 Barg) Saturated or Superheated	Metal Seat and Diaphragm	<b>S2 or S1</b>
Water and Condensate Low Temperature – 32–180°F (0–83°C)	Composition Seat and Diaphragm Metal Seat and Composition Diaphragm Metal Seat and Diaphragm	<b>B2, BB, SB, S3, S4, S6, S4N, S2N</b> S1, S2
Water and Condensate High Temperature – 180–300°F (83–149°C)	Metal Seat and Diaphragm	S1 or S2
<b>NOTES:</b>		
1) Trim designation numbers in bold are used most common and have been successfully applied in similar applications. Consult factory for the suitability of certain trims for specific services; however, the end user has final responsibility for materials selected.		
2) Metal seated trim is not recommended on any service where the flow will be dead ended down stream of the pressure reducing regulator.		

**TABLE 6  
MAXIMUM CAPACITY WITH PLUG WIDE OPEN  
(Use for Relief Valve Sizing)**

Line Size Inch	Cv	kv
3/8" (DN10)	1.8	1.6
1/2" (DN15)	1.8	1.6
3/4" (DN20)	3.7	3.2
1" (DN25)	4.0	3.5

**TABLE 7  
CAPACITY - (Cv)  
AT FLOWING PRESSURE (FL = 0.95)**

METAL DIAPHRAGM							
Flowing Pressure		3/8" (DN10) Body			1/2" (DN15) Body		
		%Droop			%Droop		
psig	(Barg)	10%	20%	30%	10%	20%	30%
5	(0.3)	0.11	0.22	0.34	0.11	0.22	0.34
10	(0.7)	0.22	0.45	0.67	0.22	0.45	0.67
15	(1.0)	0.34	0.67	1.01	0.34	0.67	1.01
25	(1.7)	0.28	0.57	0.85	0.28	0.57	0.85
35	(2.4)	0.40	0.79	1.19	0.40	0.79	1.19
50	(3.4)	0.26	0.52	0.77	0.26	0.52	0.77
75	(5.2)	0.39	0.77	1.16	0.39	0.77	1.16
100	(6.9)	0.28	0.56	0.83	0.28	0.56	0.83
135	(9.3)	0.37	0.76	1.12	0.37	0.76	1.12
150	(10.3)	0.42	0.83	1.25	0.42	0.83	1.25
175	(12.1)	0.53	1.06	1.59	0.53	1.06	1.59
200	(13.8)	0.61	1.21	1.80	0.61	1.21	1.80
225	(15.5)	0.68	1.37	1.80	0.68	1.37	1.80
250	(17.2)	0.76	1.52	1.80	0.76	1.52	1.80

COMPOSITION DIAPHRAGM							
Flowing Pressure		3/8" (DN10) Body			1/2" (DN15) Body		
		%Droop			%Droop		
psig	(Barg)	10%	20%	30%	10%	20%	30%
5	(0.3)	0.16	0.31	0.47	0.16	0.31	0.47
10	(0.7)	0.31	0.63	0.94	0.31	0.63	0.94
15	(1.0)	0.47	0.94	1.41	0.47	0.94	1.41
25	(1.7)	0.40	0.81	1.21	0.40	0.81	1.21
35	(2.4)	0.56	1.13	1.69	0.56	1.13	1.69
50	(3.4)	0.36	0.71	1.07	0.36	0.71	1.07
75	(5.2)	0.54	1.07	1.61	0.54	1.07	1.61
100	(6.9)	0.35	0.71	1.06	0.35	0.71	1.06
150	(10.3)	0.53	1.06	1.59	0.53	1.06	1.59
175	(12.1)	0.53	1.06	1.59	0.53	1.06	1.59
200	(13.8)	0.61	1.21	1.80	0.61	1.21	1.80
225	(15.5)	0.68	1.37	1.80	0.68	1.37	1.80
250	(17.2)	0.76	1.52	1.80	0.76	1.52	1.80

METAL DIAPHRAGM							
Flowing Pressure		3/4" (DN20) Body			1" (DN25) Body		
		%Droop			%Droop		
psig	(Barg)	10%	20%	30%	10%	20%	30%
5	(0.3)	0.18	0.35	0.53	0.18	0.35	0.53
10	(0.7)	0.35	0.70	1.05	0.35	0.70	1.05
15	(1.0)	0.53	1.05	1.58	0.53	1.05	1.58
25	(1.7)	0.44	0.88	1.32	0.44	0.88	1.32
35	(2.4)	0.62	1.23	1.85	0.62	1.23	1.85
50	(3.4)	0.49	0.98	1.48	0.49	0.98	1.48
75	(5.2)	0.74	1.48	2.22	0.74	1.48	2.22
100	(6.9)	0.54	1.08	1.62	0.54	1.08	1.62
135	(9.3)	0.73	1.46	2.19	0.73	1.46	2.19
150	(10.3)	0.81	1.62	2.43	0.81	1.62	2.43
175	(12.1)	1.24	2.47	3.60	1.24	2.47	3.60
200	(13.8)	1.41	2.82	3.60	1.41	2.82	3.60
225	(15.5)	1.59	3.18	3.60	1.59	3.18	3.60
250	(17.2)	1.77	3.60	3.60	1.77	3.60	3.60

COMPOSITION DIAPHRAGM							
Flowing Pressure		3/4" (DN20) Body			1" (DN25) Body		
		%Droop			%Droop		
psig	(Barg)	10%	20%	30%	10%	20%	30%
5	(0.3)	0.34	0.67	1.01	0.34	0.67	1.01
10	(0.7)	0.67	1.34	2.02	0.67	1.34	2.02
15	(1.0)	1.01	2.02	3.03	1.01	2.02	3.03
25	(1.7)	0.89	1.79	2.68	0.89	1.79	2.68
35	(2.4)	1.25	2.51	3.60	1.25	2.51	3.60
50	(3.4)	1.15	2.31	3.60	1.15	2.31	3.60
75	(5.2)	1.73	3.20	3.60	1.73	3.20	3.60
100	(6.9)	1.03	2.06	3.60	1.03	2.06	3.60
150	(10.3)	1.54	3.09	3.60	1.37	2.74	3.60
200	(13.8)	1.56	3.13	3.60	1.56	3.13	3.60
225	(15.5)	1.76	3.50	3.60	1.76	3.50	3.60
250	(17.2)	1.95	3.60	3.60	1.95	3.60	3.60

**METRIC CONVERSION FACTOR: Cv / 1.16 = kv**

**TABLE 8**  
**WATER CAPACITIES - (GPM)**  
**S.G. = 1.0 T = 60°F F<sub>L</sub> = 0.95**  
**Composition Diaphragm Only**

P2 Outlet Pressure		P1 Inlet Pressure		3/8" (DN10) Body Size			1/2" (DN15) Body Size			3/4" (DN20) Body Size			1" (DN25) Body Size		
		Pressure		DROOP			DROOP			DROOP			DROOP		
psig	(Barg)	psig	(Barg)	10%	20%	30%	10%	20%	30%	10%	20%	30%	10%	20%	30%
5	(0.34)	25	(1.7)	0.7	1.4	2.1	0.7	1.4	2.1	1.5	3.0	4.5	1.5	3.0	4.5
		50	(3.4)	1.1	2.1	3.2	1.1	2.1	3.2	2.3	4.5	6.8	2.3	4.5	6.8
		75	(5.2)	1.3	2.6	3.9	1.3	2.6	3.9	2.8	5.6	8.5	2.8	5.6	8.5
		100	(6.9)	1.6	3.0	4.6	1.6	3.0	4.6	3.3	6.5	9.8	3.3	6.5	9.8
		125	(8.6)	HI DP	HI DP	HI DP	HI DP	HI DP	HI DP	HI DP	HI DP	HI DP	HI DP	HI DP	HI DP
10	(0.69)	25	(1.7)	1.2	2.4	3.6	1.2	2.4	3.6	2.6	5.2	7.8	2.6	5.2	7.8
		50	(3.4)	2.0	4.0	5.9	2.0	4.0	5.9	4.2	8.5	12.8	4.2	8.5	12.8
		75	(5.2)	2.5	5.1	7.6	2.5	5.1	7.6	5.4	10.8	16.3	5.4	10.8	16.3
		100	(6.9)	2.9	6.0	8.9	2.9	6.0	8.9	6.4	12.7	19.2	6.4	12.7	19.2
		125	(8.6)	HI DP	HI DP	HI DP	HI DP	HI DP	HI DP	HI DP	HI DP	HI DP	HI DP	HI DP	HI DP
15	(1.0)	25	(1.7)	1.5	3.0	4.5	1.5	3.0	4.5	3.2	6.4	9.6	3.2	6.4	9.6
		50	(3.4)	2.8	5.6	8.3	2.8	5.6	8.3	6.0	12.0	17.9	6.0	12.0	17.9
		75	(5.2)	3.6	7.3	10.9	3.6	7.3	10.9	7.8	15.6	23.5	7.8	15.6	23.5
		100	(6.9)	4.3	8.7	13.0	4.3	8.7	13.0	9.3	18.6	27.9	9.3	18.6	27.9
		125	(8.6)	HI DP	HI DP	HI DP	HI DP	HI DP	HI DP	HI DP	HI DP	HI DP	HI DP	HI DP	HI DP
25	(1.7)	50	(3.4)	2.0	4.1	6.1	2.0	4.1	6.1	4.5	9.0	13.4	4.5	9.0	13.4
		75	(5.2)	2.8	5.7	8.6	2.8	5.7	8.6	6.3	12.7	19.0	6.3	12.7	19.0
		100	(6.9)	3.5	7.0	10.5	3.5	7.0	10.5	7.7	15.5	23.2	7.7	15.5	23.2
		125	(8.6)	4.0	8.1	12.1	4.0	8.1	12.1	8.9	17.9	26.8	8.9	17.9	26.8
		150	(10.3)	4.5	9.1	13.5	4.5	9.1	13.5	10.0	20.0	30.0	10.0	20.0	30.0
		175	(12.1)	HI DP	HI DP	HI DP	HI DP	HI DP	HI DP	HI DP	HI DP	HI DP	HI DP	HI DP	HI DP
35	(2.4)	50	(3.4)	2.2	4.4	6.5	2.2	4.4	6.5	4.8	9.7	13.9	4.8	9.7	13.9
		75	(5.2)	3.5	7.1	10.7	3.5	7.1	10.7	7.9	15.9	22.8	7.9	15.9	22.8
		100	(6.9)	4.5	9.1	13.6	4.5	9.1	13.6	10.1	20.2	29.0	10.1	20.2	29.0
		125	(8.6)	5.3	10.7	16.0	5.3	10.7	16.0	11.9	23.8	34.2	11.9	23.8	34.2
		150	(10.3)	6.0	12.1	18.1	6.0	12.1	18.1	13.4	26.9	38.6	13.4	26.9	38.6
175	(12.1)	HI DP	HI DP	HI DP	HI DP	HI DP	HI DP	HI DP	HI DP	HI DP	HI DP	HI DP	HI DP	HI DP	
50	(3.4)	75	(5.2)	1.8	3.6	5.4	1.8	3.6	5.4	5.8	11.6	18.0	5.8	11.6	18.0
		100	(6.9)	2.5	5.0	7.6	2.5	5.0	7.6	8.1	16.3	25.5	8.1	16.3	25.5
		125	(8.6)	3.1	6.1	9.3	3.1	6.1	9.3	10.0	20.0	31.2	10.0	20.0	31.2
		150	(10.3)	3.6	7.1	10.7	3.6	7.1	10.7	11.5	23.1	36.0	11.5	23.1	36.0
		175	(12.1)	4.0	7.9	12.0	4.0	7.9	12.0	12.9	25.8	40.2	12.9	25.8	40.2
		200	(13.8)	4.4	8.7	13.1	4.4	8.7	13.1	14.1	28.3	44.1	14.1	28.3	44.1
250	(17.2)	HI DP	HI DP	HI DP	HI DP	HI DP	HI DP	HI DP	HI DP	HI DP	HI DP	HI DP	HI DP	HI DP	
75	(5.2)	100	(6.9)	2.7	5.4	8.1	2.7	5.4	8.1	8.7	16.0	18.0	8.7	16.0	18.0
		125	(8.6)	3.8	7.6	11.4	3.8	7.6	11.4	12.2	22.6	25.5	12.2	22.6	25.5
		150	(10.3)	4.7	9.3	13.9	4.7	9.3	13.9	15.0	27.7	31.2	15.0	27.7	31.2
		175	(12.1)	5.4	10.7	16.1	5.4	10.7	16.1	17.3	32.0	36.0	17.3	32.0	36.0
		200	(13.8)	6.0	12.0	18.0	6.0	12.0	18.0	19.3	35.8	40.2	19.3	35.8	40.2
		250	(17.2)	HI DP	HI DP	HI DP	HI DP	HI DP	HI DP	HI DP	HI DP	HI DP	HI DP	HI DP	HI DP
100	(6.9)	125	(8.6)	1.8	3.6	5.3	1.8	3.6	5.3	5.2	10.3	18.0	5.2	10.3	18.0
		150	(10.3)	2.5	5.0	7.5	2.5	5.0	7.5	7.3	14.6	25.5	7.3	14.6	25.5
		175	(12.1)	3.0	6.1	9.2	3.0	6.1	9.2	8.9	17.8	31.2	8.9	17.8	31.2
		200	(13.8)	3.5	7.1	10.6	3.5	7.1	10.6	10.3	20.6	36.0	10.3	20.6	36.0
		250	(17.2)	4.3	8.7	13.0	4.3	8.7	13.0	12.6	25.2	44.1	12.6	25.2	44.1
300	(20.7)	HI DP	HI DP	HI DP	HI DP	HI DP	HI DP	HI DP	HI DP	HI DP	HI DP	HI DP	HI DP	HI DP	
150	(10.3)	175	(12.1)	2.7	5.3	8.0	2.7	5.3	8.0	7.7	15.5	18.0	7.7	15.5	18.0
		200	(13.8)	3.7	7.5	11.2	3.7	7.5	11.2	10.9	21.8	25.5	10.9	21.8	25.5
		250	(17.2)	5.3	10.6	15.9	5.3	10.6	15.9	15.4	30.9	36.0	15.4	30.9	36.0
		300	(20.7)	6.5	13.0	19.5	6.5	13.0	19.5	18.9	37.8	44.1	18.9	37.8	44.1
		350	(24.1)	HI DP	HI DP	HI DP	HI DP	HI DP	HI DP	HI DP	HI DP	HI DP	HI DP	HI DP	HI DP
175	(12.1)	200	(13.8)	2.7	5.3	8.0	2.7	5.3	8.0	6.9	13.7	18.0	6.9	13.7	18.0
		250	(17.2)	4.6	9.2	13.8	4.6	9.2	13.8	11.9	23.7	31.2	11.9	23.7	31.2
		300	(20.7)	5.9	11.9	17.8	5.9	11.9	17.8	15.3	30.6	40.2	15.3	30.6	40.2
		350	(24.1)	HI DP	HI DP	HI DP	HI DP	HI DP	HI DP	HI DP	HI DP	HI DP	HI DP	HI DP	HI DP
200	(13.8)	250	(17.2)	4.3	8.6	12.7	4.3	8.6	12.7	11.0	22.1	25.5	11.0	22.1	25.5
		300	(20.7)	6.1	12.1	18.0	6.1	12.1	18.0	15.6	31.3	36.0	15.6	31.3	36.0
		350	(24.1)	7.5	14.8	22.0	7.5	14.8	22.0	19.1	38.3	44.1	19.1	38.3	44.1
		400	(27.6)	HI DP	HI DP	HI DP	HI DP	HI DP	HI DP	HI DP	HI DP	HI DP	HI DP	HI DP	HI DP
225	(15.5)	250	(17.2)	3.4	6.9	9.0	3.4	6.9	9.0	8.8	17.5	18.0	8.8	17.5	18.0
		300	(20.7)	5.9	11.9	15.6	5.9	11.9	15.6	15.2	30.3	31.2	15.2	30.3	31.2
		350	(24.1)	7.6	15.3	20.1	7.6	15.3	20.1	19.7	39.1	40.2	19.7	39.1	40.2
		400	(27.6)	HI DP	HI DP	HI DP	HI DP	HI DP	HI DP	HI DP	HI DP	HI DP	HI DP	HI DP	HI DP
250	(17.2)	300	(20.7)	5.4	10.7	12.7	5.4	10.7	12.7	13.8	25.5	25.5	13.8	25.5	25.5
		350	(24.1)	7.6	15.2	18.0	7.6	15.2	18.0	19.5	36.0	36.0	19.5	36.0	36.0
		400	(27.6)	9.3	18.6	22.0	9.3	18.6	22.0	23.9	44.1	44.1	23.9	44.1	44.1

Where "HI DP" is indicated, the actual pressure drop has exceeded the recommended limits of Table 2.  
**Metric Conversion Factor: GPM X 3.785 = LPM**

**TABLE 9**  
**AIR CAPACITY (SCFH)**  
**S.G. = 1.0 T - 60°F; F<sub>L</sub> - 0.95**  
**Composition Diaphragm Only**

P2 Outlet Pressure psig (Barg)		P1 Inlet Pressure psig (Barg)		3/8" (DN10) Body Size DROOP			1/2" (DN15) Body Size DROOP			3/4" (DN20) Body Size DROOP			1" (DN25) Body Size DROOP		
psig	(Barg)	psig	(Barg)	10%	20%	30%	10%	20%	30%	10%	20%	30%	10%	20%	30%
5	(0.34)	25	(1.7)	200	400	600	200	400	600	400	800	1300	400	800	1300
		50	(3.4)	300	600	1000	300	600	1000	700	1400	2100	700	1400	2100
		75	(5.2)	500	900	1300	500	900	1300	1000	1900	2900	1000	1900	2900
		100	(6.9)	600	1100	1700	600	1100	1700	1200	2400	3700	1200	2400	3700
		125	(8.6)	700	1400	2100	700	1400	2100	1500	3000	4500	1500	3000	4500
		150	(10.3)	800	1600	2500	800	1600	2500	1800	3500	5300	1800	3500	5300
		175	(12.1)	1000	1900	2800	1000	1900	2800	2100	4100	6100	2100	4100	6100
		200	(13.8)	1100	2100	3200	1100	2100	3200	2300	4600	6900	2300	4600	6900
		250	(17.2)	HI DP	HI DP	HI DP	HI DP	HI DP	HI DP	HI DP	HI DP	HI DP	HI DP	HI DP	HI DP
10	(0.69)	25	(1.7)	400	800	1200	400	800	1200	800	1700	2500	800	1700	2500
		50	(3.4)	600	1300	1900	600	1300	1900	1400	2800	4200	1400	2800	4200
		75	(5.2)	900	1800	2700	900	1800	2700	1900	3800	5800	1900	3800	5800
		100	(6.9)	1100	2300	3400	1100	2300	3400	2400	4900	7400	2400	4900	7400
		125	(8.6)	1400	2800	4200	1400	2800	4200	3000	6000	9000	3000	6000	9000
		150	(10.3)	1600	3300	4900	1600	3300	4900	3500	7000	10600	3500	7000	10600
		175	(12.1)	1900	3800	5700	1900	3800	5700	4100	8100	12200	4100	8100	12200
		200	(13.8)	2100	4300	6400	2100	4300	6400	4600	9200	13800	4600	9200	13800
		250	(17.2)	2600	5300	7900	2600	5300	7900	5700	11300	17100	5700	11300	17100
15	(1.0)	25	(1.7)	600	1100	1700	600	1100	1700	1200	2400	3600	1200	2400	3600
		50	(3.4)	1000	1900	2900	1000	1900	2900	2100	4200	6200	2100	4200	6200
		75	(5.2)	1300	2700	4000	1300	2700	4000	2900	5800	8600	2900	5800	8600
		100	(6.9)	1700	3400	5100	1700	3400	5100	3700	7400	11100	3700	7400	11100
		125	(8.6)	2100	4200	6300	2100	4200	6300	4500	9000	13500	4500	9000	13500
		150	(10.3)	2500	4900	7400	2500	4900	7400	5300	10600	15900	5300	10600	15900
		175	(12.1)	2800	5700	8500	2800	5700	8500	6100	12200	18300	6100	12200	18300
		200	(13.8)	3200	6400	9700	3200	6400	9700	6900	13800	20800	6900	13800	20800
		250	(17.2)	HI DP	HI DP	HI DP	HI DP	HI DP	HI DP	HI DP	HI DP	HI DP	HI DP	HI DP	HI DP
20	(1.7)	50	(3.4)	800	1600	2400	800	1600	2400	1800	3600	5400	1800	3600	5400
		75	(5.2)	1100	2300	3500	1100	2300	3500	2500	5100	7700	2500	5100	7700
		100	(6.9)	1500	3000	4400	1500	3000	4400	3300	6500	9800	3300	6500	9800
		125	(8.6)	1800	3600	5400	1800	3600	5400	4000	8000	11900	4000	8000	11900
		150	(10.3)	2100	4300	6400	2100	4300	6400	4700	9400	14100	4700	9400	14100
		175	(12.1)	2400	4900	7300	2400	4900	7300	5400	10800	16200	5400	10800	16200
		200	(13.8)	2700	5500	8300	2700	5500	8300	6100	12300	18400	6100	12300	18400
		250	(17.2)	3400	6800	10200	3400	6800	10200	7500	15100	22600	7500	15100	22600
		300	(20.7)	4000	8100	12200	4000	8100	12200	8900	18000	26900	8900	18000	26900
		350	(24.1)	4700	9400	14100	4700	9400	14100	10400	20800	31200	10400	20800	31200
		400	(27.6)	HI DP	HI DP	HI DP	HI DP	HI DP	HI DP	HI DP	HI DP	HI DP	HI DP	HI DP	HI DP
35	(2.4)	50	(3.4)	1000	2000	3000	1000	2000	3000	2200	4500	6400	2200	4500	6400
		75	(5.2)	1600	3200	4800	1600	3200	4800	3500	7100	10200	3500	7100	10200
		100	(6.9)	2000	4100	6200	2000	4100	6200	4600	9200	13100	4600	9200	13100
		125	(8.6)	2500	5000	7500	2500	5000	7500	5600	11200	16000	5600	11200	16000
		150	(10.3)	2900	5900	8900	2900	5900	8900	6600	13200	18900	6600	13200	18900
		175	(12.1)	3400	6800	10200	3400	6800	10200	7600	15200	21800	7600	15200	21800
		200	(13.8)	3800	7700	11600	3800	7700	11600	8600	17200	24700	8600	17200	24700
		250	(17.2)	4700	9500	14300	4700	9500	14300	10600	21200	30400	10600	21200	30400
		300	(20.7)	5600	11400	17000	5600	11400	17000	12600	25200	36200	12600	25200	36200
		350	(24.1)	6500	13200	SONIC	6500	13200	19700	14600	29200	41900	14600	29200	41900
		400	(27.6)	HI DP	HI DP	HI DP	HI DP	HI DP	HI DP	HI DP	HI DP	HI DP	HI DP	HI DP	HI DP
50	(3.4)	75	(5.2)	900	1800	2700	900	1800	2700	2900	5900	9200	2900	5900	9200
		100	(6.9)	1300	2500	3800	1300	2500	3800	4100	8300	12900	4100	8300	12900
		125	(8.6)	1600	3200	4800	1600	3200	4800	5100	10300	16000	5100	10300	16000
		150	(10.3)	1900	3700	5600	1900	3700	5600	6000	12100	18900	6000	12100	18900
		175	(12.1)	2200	4300	6500	2200	4300	6500	7000	14000	21800	7000	14000	21800
		200	(13.8)	2500	4900	7300	2500	4900	7300	7900	15800	24700	7900	15800	24700
		250	(17.2)	3000	6000	9000	3000	6000	9000	9700	19500	30400	9700	19500	30400
		300	(20.7)	3600	7100	10800	3600	7100	10800	11600	23200	36200	11600	23200	36200
		350	(24.1)	4200	8300	12500	4200	8300	12500	13400	26900	41900	13400	26900	41900
		400	(27.6)	4800	9400	14200	4800	9400	14200	15200	30600	47700	15200	30600	47700

**NOTE:** Where "HI DP" is indicated, the actual pressure drop has exceeded the recommended limits of Table 2.

Where "SONIC" is indicated, outlet velocity with Schedule 40 pipe exceeds sonic velocity of 1118 fps. Additional flow cannot be obtained, and pipeline velocity is in excess of customary pipe velocity design limits. Flow will be approximately the last indicated value in the column above "SONIC".



Recommend use of Opt-4 Stabilizer.

**Metric Conversion Factors:** SCFH / 35.31 = Sm<sup>3</sup>/Hr; SCFH / 37.32 = N-m<sup>3</sup>/Hr

**TABLE 9 (continued)**  
**AIR CAPACITY (SCFH)**  
**S.G. = 1.0; T - 60°F F<sub>L</sub> - 0.95**  
**Composition Diaphragm Only**

P2 Outlet Pressure		P1 Inlet Pressure		3/8" (DN10) Body Size DROOP			1/2" (DN15) Body Size DROOP			3/4" (DN20) Body Size DROOP			1" (DN25) Body Size DROOP		
psig	(Barg)	psig	(Barg)	10%	20%	30%	10%	20%	30%	10%	20%	30%	10%	20%	30%
75	(5.2)	100	(6.9)	1600	3200	4800	1600	3200	4800	5200	9500	10700	5200	9500	10700
		125	(8.6)	2300	4500	6700	2300	4500	6700	7200	13400	15000	7200	13400	15000
		150	(10.3)	2800	5500	8300	2800	5500	8300	8900	16500	18500	8900	16500	18500
		175	(12.1)	3300	6400	9700	3300	6400	9700	10400	19300	21700	10400	19300	21700
		200	(13.8)	3700	7300	11000	3700	7300	11000	11800	21900	24700	11800	21900	24700
		250	(17.2)	4600	9000	13600	4600	9000	13600	14600	27000	30400	14600	27000	30400
		300	(20.7)	5400	10800	16200	5400	10800	16200	17400	32200	36200	17400	32200	36200
		350	(24.1)	6300	12500	18800	6300	12500	18800	20100	37300	41900	20100	37300	41900
100	(6.9)	125	(8.6)	1200	2400	3500	1200	2400	3500	3400	6900	12000	3400	6900	12000
		150	(10.3)	1600	3300	5000	1600	3300	5000	4800	9700	16900	4800	9700	16900
		175	(12.1)	2000	4100	6100	2000	4100	6100	5900	11900	20800	5900	11900	20800
		200	(13.8)	2400	4800	7100	2400	4800	7100	6900	13800	24200	6900	13800	24200
		250	(17.2)	3000	6000	8900	3000	6000	8900	8700	17400	30400	8700	17400	30400
		300	(20.7)	3500	7100	10700	3500	7100	10700	10400	20700	36200	10400	20700	36200
		350	(24.1)	4100	8300	12300	4100	8300	12300	12000	24000	41900	12000	24000	41900
		400	(27.6)	4600	9400	14000	4600	9400	14000	13600	27300	47700	13600	27300	47700
150	(10.3)	175	(12.1)	2100	4200	6300	2100	4200	6300	6100	12300	14300	6100	12300	14300
		200	(13.8)	3000	5900	8900	3000	5900	8900	8600	17300	20100	8600	17300	20100
		250	(17.2)	4200	8400	12600	4200	8400	12600	12200	24500	28600	12200	24500	28600
		300	(20.7)	5200	10400	15700	5200	10400	15700	15200	30500	35500	15200	30500	35500
		350	(24.1)	6100	12300	18400	6100	12300	18400	17900	35800	41700	17900	35800	41700
		400	(27.6)	7000	14000	21100	7000	14000	21100	20400	40900	47700	20400	40900	47700
175	(12.1)	200	(13.8)	2200	4500	6700	2200	4500	6700	5800	11600	15300	5800	11600	15300
		250	(17.2)	3900	7800	11600	3900	7800	11600	10000	20100	26400	10000	20100	26400
		300	(20.7)	5000	10100	15100	5000	10100	15100	13000	26100	34300	13000	26100	34300
		350	(24.1)	6100	12100	18200	6100	12100	18200	15600	31300	41100	15600	31300	41100
200	(13.8)	400	(27.6)	7000	14000	20900	7000	14000	20900	18000	36100	47400	18000	36100	47400
		250	(17.2)	3900	7700	11400	3900	7700	11400	9900	19900	22800	9900	19900	22800
		300	(20.7)	5500	10900	16200	5500	10900	16200	14000	28100	32400	14000	28100	32400
		350	(24.1)	6800	13400	20000	6800	13400	20000	17300	34800	40000	17300	34800	40000
225	(15.5)	400	(27.6)	7900	15700	23400	7900	15700	23400	20300	40700	46800	20300	40700	46800
		250	(17.2)	3200	6500	8500	3200	6500	8500	8400	16600	17100	8400	16600	17100
		300	(20.7)	5600	11200	14800	5600	11200	14800	14400	28700	29500	14400	28700	29500
		350	(24.1)	7200	14600	19100	7200	14600	19100	18700	37200	38200	18700	37200	38200
250 (17.2)	(17.2)	400	(27.6)	8600	17400	22800	8600	17400	22800	22300	44400	45700	22300	44400	45700
		300	(20.7)	5300	10700	12600	5300	10700	12600	13700	25300	25300	13700	25300	25300
		350	(24.1)	7600	15100	17900	7600	15100	17900	19400	35800	35800	19400	35800	35800
400	(27.6)	9300	18600	22000	9300	18600	22000	23900	44100	44100	23900	44100	44100		

NOTE:  Recommend use of Opt-4 Stabilizer.

Metric Conversion Factors: SCFH / 35.31 = Sm<sup>3</sup>/Hr; SCFH / 37.32 = N-m<sup>3</sup>/Hr

**TABLE 10**  
**STEAM (LBS/HR)**  
**S.G. = Actual; T = Saturated; F<sub>L</sub> = 0.95**  
**Metal Diaphragm Only**

P2 Outlet Pressure		P1 Inlet Pressure		3/8" (DN10) Body Size DROOP			1/2" (DN15) Body Size DROOP			3/4" (DN20) Body Size DROOP			1" (DN25) Body Size DROOP		
psig	(Barg)	psig	(Barg)	10%	20%	30%	10%	20%	30%	10%	20%	30%	10%	20%	30%
2	(.14)	25	(1.7)	3	6	10	3	6	10	5	10	14	5	10	14
		50	(3.4)	5	10	16	5	10	16	8	16	24	8	16	24
		75	(5.2)	6	14	22	6	14	22	11	22	33	11	22	33
		100	(6.9)	8	18	28	8	18	28	14	28	42	14	28	42
		125	(8.6)	10	22	34	10	22	34	17	34	51	17	34	51
		150	(10.3)	11	26	40	11	26	40	20	40	60	20	40	60
		175	(12.1)	HI DP	HI DP	HI DP	HI DP	HI DP	HI DP	HI DP	HI DP	HI DP	HI DP	HI DP	HI DP
5	(.34)	25	(1.7)	7	15	23	7	15	23	12	23	35	12	23	35
		50	(3.4)	12	24	38	12	24	38	20	39	59	20	39	59
		75	(5.2)	17	35	54	17	35	54	28	55	83	28	55	83
		100	(6.9)	22	44	68	22	44	68	36	70	106	36	70	106
		125	(8.6)	27	53	82	27	53	82	44	85	128	44	85	128
		150	(10.3)	31	63	97	31	63	97	51	100	151	51	100	151
		175	(12.1)	HI DP	HI DP	HI DP	HI DP	HI DP	HI DP	HI DP	HI DP	HI DP	HI DP	HI DP	HI DP
10	(.69)	25	(1.7)	14	28	42	14	28	42	22	44	65	22	44	65
		50	(3.4)	24	49	74	24	49	74	38	77	115	38	77	115
		75	(5.2)	34	69	103	34	69	103	54	108	161	54	108	161
		100	(6.9)	44	90	134	44	90	134	70	140	210	70	140	210
		125	(8.6)	53	109	162	53	109	162	85	170	254	85	170	254
		150	(10.3)	63	128	190	63	128	190	100	199	299	100	199	299
		175	(12.1)	HI DP	HI DP	HI DP	HI DP	HI DP	HI DP	HI DP	HI DP	HI DP	HI DP	HI DP	HI DP
15	(1.0)	25	(1.7)	19	37	55	19	37	55	29	57	86	29	57	86
		50	(3.4)	37	72	109	37	72	109	57	113	171	57	113	171
		75	(5.2)	52	102	153	52	102	153	80	159	239	80	159	239
		100	(6.9)	67	133	200	67	133	200	105	208	312	105	208	312
		125	(8.6)	82	162	245	82	162	245	128	254	383	128	254	383
		150	(10.3)	97	190	287	97	190	287	151	299	449	151	299	449
		175	(12.1)	HI DP	HI DP	HI DP	HI DP	HI DP	HI DP	HI DP	HI DP	HI DP	HI DP	HI DP	HI DP
25	(1.7)	25	(1.7)	28	57	85	28	57	85	44	88	132	44	88	132
		50	(3.4)	42	85	127	42	85	127	66	131	197	66	131	197
		75	(5.2)	54	110	164	54	110	164	85	169	254	85	169	254
		100	(6.9)	66	134	200	66	134	200	104	207	311	104	207	311
		125	(8.6)	80	162	242	80	162	242	125	250	375	125	250	375
		150	(10.3)	91	186	278	91	186	278	144	287	431	144	287	431
		175	(12.1)	HI DP	HI DP	HI DP	HI DP	HI DP	HI DP	HI DP	HI DP	HI DP	HI DP	HI DP	HI DP
35	(2.4)	40	(2.8)	57	113	170	57	113	170	89	176	264	89	176	264
		65	(4.5)	76	150	226	76	150	226	118	233	351	118	233	351
		90	(6.2)	93	184	277	93	184	277	144	287	431	144	287	431
		115	(7.9)	110	216	326	110	216	326	170	337	507	170	337	507
		140	(9.7)	129	255	383	129	255	383	200	396	596	200	396	596
		165	(11.4)	HI DP	HI DP	HI DP	HI DP	HI DP	HI DP	HI DP	HI DP	HI DP	HI DP	HI DP	HI DP
50	(3.4)	75	(5.2)	59	119	176	59	119	176	112	224	338	112	224	338
		100	(6.9)	71	141	209	71	141	209	133	267	402	133	267	402
		125	(8.6)	82	163	242	82	163	242	154	308	465	154	308	465
		150	(10.3)	92	185	274	92	185	274	174	348	526	174	348	526
		200	(13.8)	HI DP	HI DP	HI DP	HI DP	HI DP	HI DP	HI DP	HI DP	HI DP	HI DP	HI DP	HI DP
75	(5.2)	100	(6.9)	120	236	356	120	236	356	227	454	681	227	454	681
		125	(8.6)	137	271	408	137	271	408	260	520	780	260	520	780
		175	(12.1)	HI DP	HI DP	HI DP	HI DP	HI DP	HI DP	HI DP	HI DP	HI DP	HI DP	HI DP	HI DP
100	(6.9)	150	(10.3)	120	241	357	120	241	357	232	464	697	232	464	697
		200	(13.8)	HI DP	HI DP	HI DP	HI DP	HI DP	HI DP	HI DP	HI DP	HI DP	HI DP	HI DP	HI DP
135	(9.3)	165	(11.4)	HI DP	HI DP	HI DP	HI DP	HI DP	HI DP	HI DP	HI DP	HI DP	HI DP	HI DP	HI DP

NOTE: Where "HI DP" is indicated, the actual pressure drop has exceeded the recommended limits of Table 2.

Metric Conversion Factor: LBS/HR X 0.4536 = KG/HR

## DIMENSIONS & WEIGHTS

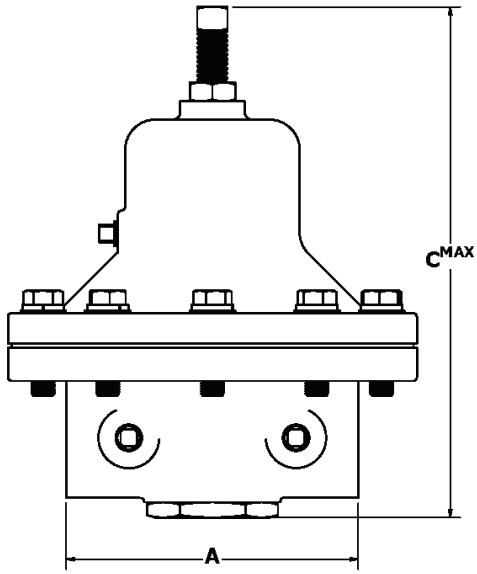

**STANDARD CONFIGURATION**  
(shown with Option -87 gauge ports)

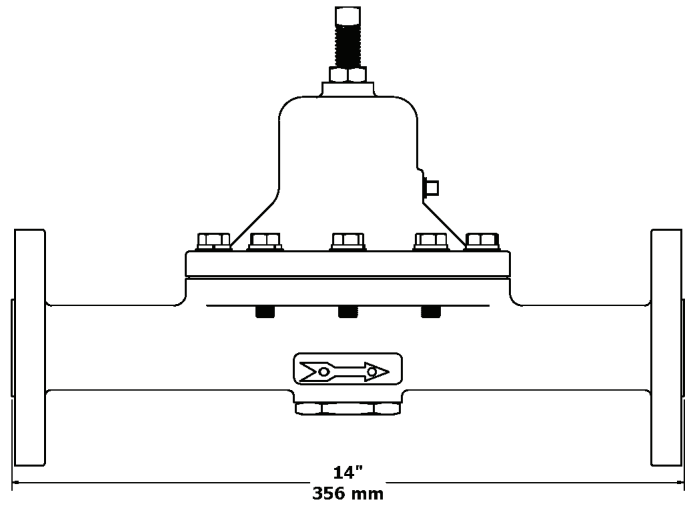

**STANDARD CONFIGURATION**  
**FLANGED END CONNECTIONS**

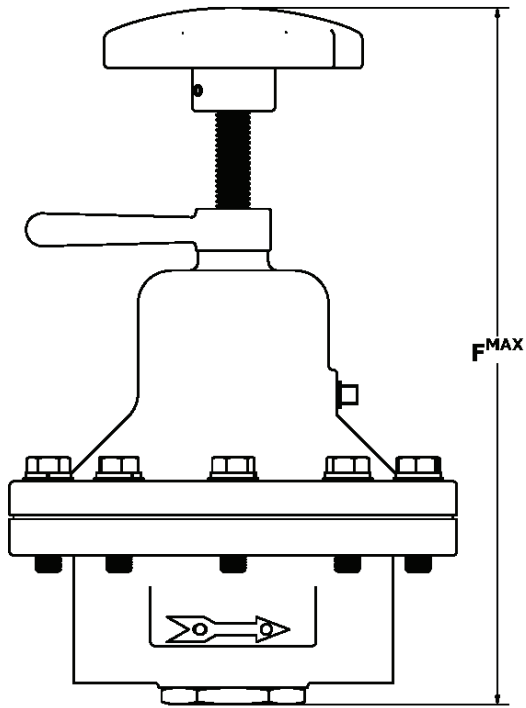

**OPTION -3**  
**HANDWHEEL AND LOCKING LEVER**

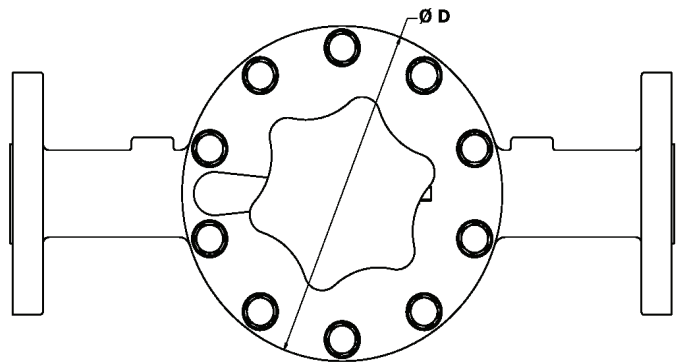

**OPTION -3**  
**HANDWHEEL AND LOCKING LEVER**  
(TOP VIEW)

## DIMENSIONS & WEIGHTS

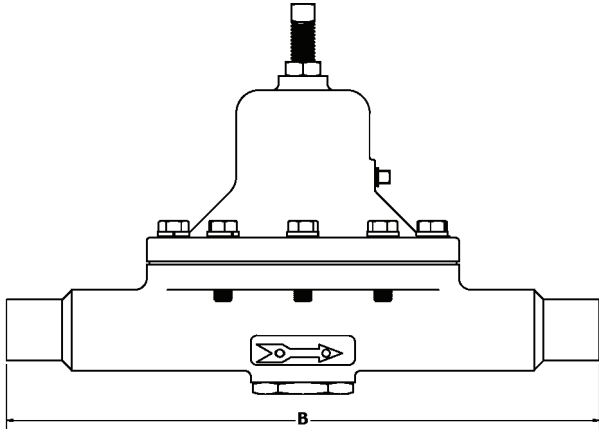

**OPTION -32**  
EXTENDED NIPPLES

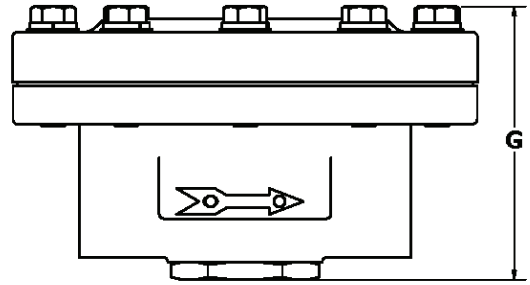

**OPTION -20**  
DOME LOADED

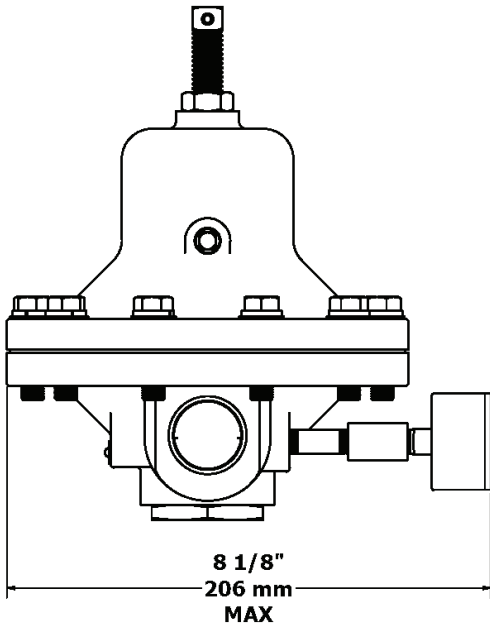

**OPTION-37 WITH OPTION-87**  
(SIDE VIEW)

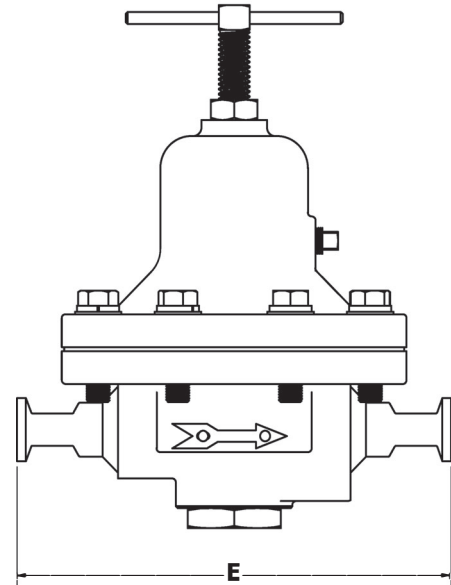

**OPTION -37 WITH OPTION-87**  
(FRONT VIEW)

SIZE INCH	DIMENSIONS (in.)									ASSEMBLED WEIGHT (lbs)	
	A	B	C <sub>MAX</sub>	C <sub>MAX</sub> +OPTION-80	D	E	F <sub>MAX</sub>	F <sub>MAX</sub> +OPTION-80	G	NON-FLANGED	FLANGED
3/8"	3 3/4	N/A	7 7/8	9 1/4	5 1/2	N/A	9 11/16	10 1/2	3 15/16	11	N/A
1/2"	3 3/4	11 3/4	7 7/8	9 1/4	5 1/2	7	9 11/16	10 1/2	3 15/16	11	18
3/4"	4 13/16	12 13/16	8 7/16	9 5/8	6 3/4	7 11/16	10 9/16	11 3/8	3 13/16	17	26
1"	4 13/16	12 13/16	8 7/16	9 5/8	6 3/4	7 11/16	10 9/16	11 3/8	3 13/16	17	27
SIZE DN	DIMENSIONS (mm)									ASSEMBLED WEIGHT (kgs)	
	A	B	C <sub>MAX</sub>	C <sub>MAX</sub> +OPTION-80	D	E	F <sub>MAX</sub>	F <sub>MAX</sub> +OPTION-80	G	NON-FLANGED	FLANGED
10	95	N/A	200	235	140	N/A	246	267	97	5	N/A
15	95	298	200	235	140	178	246	267	97	5	8
20	122	325	214	244	171	195	268	289	100	8	12
25	122	325	214	244	171	195	268	289	100	8	12

# MODEL D - Food and Pharmaceutical Industry (Option -37)

07/23/21

**2K** POS 3 — **A** POS 6 & 7 **7** — POS 10 POS 11 **000** POS 15 **00D**

POSITION 3 - SIZES		
Size		CODE
in	(DN)	
3/8"	(10)	3
1/2"	(15)	4
3/4"	(20)	5
1"	(25)	6

POSITION 6 & 7 TRIM DESIGNATION NUMBERS	
Stainless Steel Trim	
Desig.	CODE
S1	S1
S6	S6

POSITION 10 - END CONNECTIONS	
Description	CODE
NPT	1
Tri-Clamp for sizes 1/2", 3/4" & 1"	T

POSITION 11 - RANGE SPRINGS		
Range Spring		CODE
psig	(Barg)	
2-15	(.14-1.0)	A
10-40	(.69-2.8)	B
30-80	(2.1-5.5)	C

POSITION 15 - BODY OPTIONS		
Description	Option	CODE
No Option	---	0
Gauge and Ports Included: Inlet & Outlet	-87	V

# MODEL D - Dome Loaded (Option -20)

07/23/21

**2L** POS 3 — POS 5 POS 6 & 7 **7** — POS 10 **0** POS 12 **00V** POS 16 **0D**

POSITION 3 - LINE SIZE		
Size		CODE
in	(DN)	
3/8"	(10)	3
1/2"	(15)	4
3/4"	(20)	5
1"	(25)	6

POSITION 5 - BODY & COVER DOME MATERIALS	
Material	CODE
DI/BRZ	6
DI/CS	C
BRZ/BRZ	3
CS/CS	5
SST/CS	9
SST/SST	A

POSITION 6 & 7 - TRIM DESIGNATION NUMBERS			
Brass Trim		Stainless Steel Trim	
Desig.	CODE	Desig.	CODE
B2	B2	S2N	S2N
B4	B4	S3	S3
BB	BB	S4	S4
BJ	BJ	S4N	S4N
BK	BK	S6	S6
		SK	SK
		S40	40
		S40B	4B
		S40C	4C
		S40T	4T
		S40V	4V
		SB	SB
		SG	SG

POSITION 10 - END CONNECTIONS	
Description	CODE
NPT - Threaded	1
ASME 150 Flanges (14" Face to Face Dimension)	V
ASME 300 Flanges (14" Face to Face Dimension)	W
PN40 Flanges (356mm Face to Face Dimension)	A
Opt. -31: BSPT Taper Threaded	B
Opt. -31P: BSPP Parallel Threaded	P
Opt. -32: Plain End Extended Nipples	E

POSITION 12 - TRIM OPTIONS		
Description	Option	CODE
No Option	---	0
Piston Stabilizer Included	-4	4

POSITION 16 - SERVICE OPTIONS		
Description	Option	CODE
No Option	---	0
Oxygen Cleaning Per Cashco Specification S-1134	-55	M
Non-Oxygen Cleaning Per Cashco Specification S-1542	-56	N

# MODEL D - Cryogenic Service

07/23/21

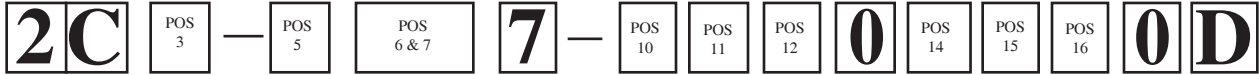

POSITION 3 - SIZES		
Size		CODE
in	(DN)	
3/8"	(10)	3
1/2"	(15)	4
3/4"	(20)	5
1"	(25)	6

POSITION 5 - BODY & SPRING CHAMBER MATERIALS		
Body / Sp. Ch.	Option	CODE
BRZ/BRZ	-5 *	3
BRZ/BRZ	-5+80 *	L
SST/SST	-36 *	A
SST/BRZ	-36+80 *	B
SST/SST	**	C
CS/CS (LCC)	**	D

\* Cleaned per Spec #S-1134 (Opt.-55)  
\*\* Minimum temperature -50° F (-46° C)

POSITION 6 & 7 - TRIM DESIGNATION NUMBERS					
Brass Trim		Stainless Steel Trim		Monel Trim	
Desig.	CODE	Desig.	CODE	Desig.	CODE
B0	B0	S0	S0	M1	M1
B1	B1	S1	S1	M36	M6
B5	B5	S9	S9		
		S36	36		
		S40B *	4B		
		S40C *	4C		

\* NACE Trim uses w/ CS or SST Body down to -50° F (-46° C)

POSITION 10 - END CONNECTIONS	
Description	CODE
NPT - Threaded	1
ASME 150 Flanges (14" Face to Face Dimension) *	V
ASME 300 Flanges (14" Face to Face Dimension) *	W
PN40 Flanges (356mm Face to Face Dimension) *	A
Opt. -31: BSPT Taper Threaded	B
Opt. -31: BSPP Parallel Threaded	P

\* LLC/SST Bodies Only

POSITION 12 - TRIM OPTIONS		
Description	Option	CODE
No Option	---	0
Piston Stabilizer Included	-4	4

POSITION 14 - OPTIONS	
Description	CODE
No Option (Includes Polyethylene Vented Plug)	0
Stainless Steel Vented Plug	H

POSITION 11 - RANGE SPRINGS		
psi	(Bar)	CODE
2-15	(.14-1.0)	1
10-40	(.69-2.8)	2
30-80	(2.1-5.5)	3
70-150	(4.8-10.3)	4
100-250 (6.9-17.2) Opt. -80 only		P

POSITION 15 - BODY OPTIONS		
Description	Option	CODE
No Option	---	0
Gauge Ports Included: Inlet & Outlet	-87	V

POSITION 16 - SERVICE OPTIONS		
Description	Option	CODE
No Option	---	0
NACE Const: CS/CS/XX Per MR0175, S40B, S40C Trims.	-40	J
NACE Const: SST/SST/XX Per MR0175, S40B, S40C Trims. Not Available for Opt-36.	-40SST	K

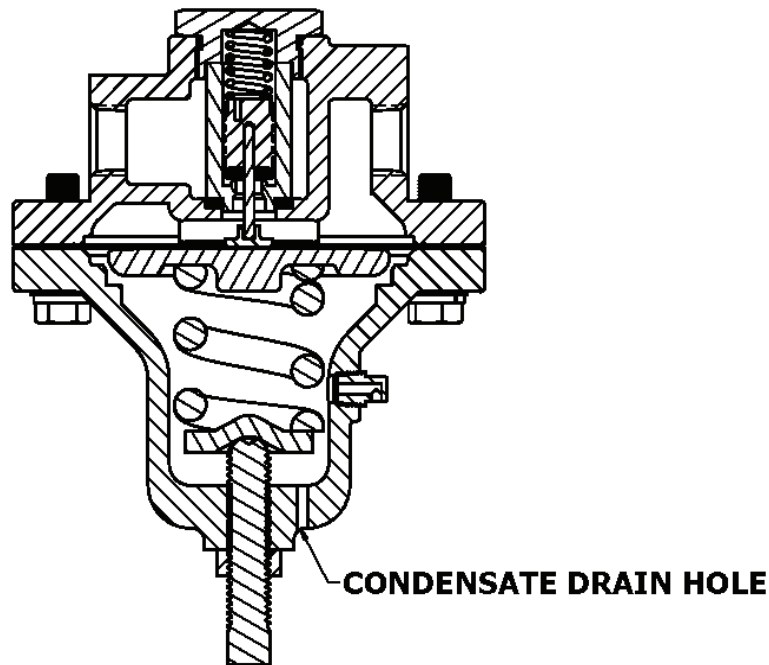

## CRYOGENIC CONSTRUCTION

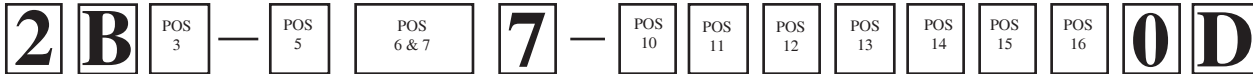

POSITION 3 - SIZES		
Size		CODE
in	(DN)	
3/8"	(10)	3
1/2"	(15)	4
3/4"	(20)	5
1"	(25)	6

POSITION 5 - BODY & SPRING CHAMBER MATERIALS		
Opt.	Body/ Sp. Ch.	CODE
Std.	DI/DI	1
	BRZ/DI	2
	BRZ/BRZ	3
	CS/DI	4
	CS/CS	5
	SST/DI	7
	SST/CS	9
	SST/SST	A
-80	BRZ/BRZ	L
	CS/BRZ	J
	DI/BRZ	M
	SST/BRZ	K

POSITION 6 & 7 - TRIM DESIGNATION NUMBERS					
Brass Trim		Stainless Steel Trim		Monel Trim	
Desig.	CODE	Desig.	CODE	Desig.	CODE
B0	B0	S0	S0	M1	M1
B1	B1	S1	S1	M36	M6
B2	B2	S2	S2		
B4	B4	S2N	SN		
B5	B5	S3	S3		
BB	BB	S4	S4		
BJ	BJ	S4N	SD		
BK	BK	S6	S6		
		S9	S9		
		SK	SK		
		S36	36		
		S40	40		
		S40B	4B		
		S40C	4C		
		S40T	4T		
		S40V	4V		
		SB	SB		
		SG	SG		

POSITION 10 - END CONNECTIONS	
Description	CODE
NPT - Threaded	1
ASME 150 Flanges (14" Face to Face Dimension) *	V
ASME 300 Flanges (14" Face to Face Dimension) *	W
PN40 Flanges (356mm Face to Face Dimension) *	A
Opt. -31: BSPT Taper Threaded	B
Opt. -31P: BSPP Parallel Threaded	P
Opt. -32: Plain End Extended Nipples *	E

\* CS/SST Bodies-1/2", 3/4", & 1" Sizes Only, Nipples of same material as body.

POSITION 12 - TRIM OPTIONS		
Description	Option	CODE
No Option	---	0
Piston Stabilizer Included	-4	4

POSITION 11 - RANGE SPRINGS		
psig	(Bar)	CODE
2-15	(.14-1.0)	1
10-40	(.69-2.8)	2
30-80	(2.1-.5.5)	3
70-150	(4.8-10.3)	4
100-250 (6.9-17.2) Opt. -80 only		P

POSITION 13 - FEATURE OPTIONS		
Description	Option	CODE
No Option	---	0
Handwheel & Locking Lever	-3	3

POSITION 14 - SPRING CHAMBER OPTIONS		
Description	Option	CODE
Polyethylene Vented Plug	---	0
Stainless Steel Vented Plug	-25S	H

POSITION 15 - BODY OPTIONS		
Description	Option	CODE
No Option	---	0
Gauge Ports Included: Inlet & Outlet	-87	V

POSITION 16 - SERVICE OPTIONS		
Description	Option	CODE
No Option	---	0
NACE Const: CS/CS/XX Per MR0175, S40, S40T, S40V Trims	-40	J
NACE Const: SST/SST/XX Per MR0175, S40, S40T, S40V Trims	-40SST	K
Oxygen Cleaning Per Cashco Specification S-1134	-55	M
Non-Oxygen Cleaning Per Cashco Specification S-1542	-56	N

**\* For information on ATEX see pages 8 & 9 on the IOM.**

- Алматы (7273)495-231
- Ангарск (3955)60-70-56
- Архангельск (8182)63-90-72
- Астрахань (8512)99-46-04
- Барнаул (3852)73-04-60
- Белгород (4722)40-23-64
- Благовещенск (4162)22-76-07
- Брянск (4832)59-03-52
- Владивосток (423)249-28-31
- Владикавказ (8672)28-90-48
- Владимир (4922)49-43-18
- Волгоград (844)278-03-48
- Вологда (8172)26-41-59
- Воронеж (473)204-51-73
- Екатеринбург (343)384-55-89

- Иваново (4932)77-34-06
- Ижевск (3412)26-03-58
- Иркутск (395)279-98-46
- Казань (843)206-01-48
- Калининград (4012)72-03-81
- Калуга (4842)92-23-67
- Кемерово (3842)65-04-62
- Киров (8332)68-02-04
- Колмна (4966)23-41-49
- Кострома (4942)77-07-48
- Краснодар (861)203-40-90
- Красноярск (391)204-63-61
- Курск (4712)77-13-04
- Курган (3522)50-90-47
- Липецк (4742)52-20-81

- Магнитогорск (3519)55-03-13
- Москва (495)268-04-70
- Мурманск (8152)59-64-93
- Набережные Челны (8552)20-53-41
- Нижний Новгород (831)429-08-12
- Новокузнецк (3843)20-46-81
- Ноябрьск (3496)41-32-12
- Новосибирск (383)227-86-73
- Омск (3812)21-46-40
- Орел (4862)44-53-42
- Оренбург (3532)37-68-04
- Пенза (8412)22-31-16
- Петрозаводск (8142)55-98-37
- Псков (8112)59-10-37
- Пермь (342)205-81-47

- Ростов-на-Дону (863)308-18-15
- Рязань (4912)46-61-64
- Самара (846)206-03-16
- Санкт-Петербург (812)309-46-40
- Саратов (845)249-38-78
- Севастополь (8692)22-31-93
- Саранск (8342)22-96-24
- Симферополь (3652)67-13-56
- Смоленск (4812)29-41-54
- Сочи (862)225-72-31
- Ставрополь (8652)20-65-13
- Сургут (3462)77-98-35
- Сыктывкар (8212)25-95-17
- Тамбов (4752)50-40-97
- Тверь (4822)63-31-35

- Тольятти (8482)63-91-07
- Томск (3822)98-41-53
- Тула (4872)33-79-87
- Тюмень (3452)66-21-18
- Ульяновск (8422)24-23-59
- Улан-Удэ (3012)59-97-51
- Уфа (347)229-48-12
- Хабаровск (4212)92-98-04
- Чебоксары (8352)25-53-07
- Челябинск (351)202-03-61
- Череповец (8202)49-02-64
- Чита (3022)38-34-83
- Якутск (4112)23-90-97
- Ярославль (4852)69-52-93