



ISO Registered Company



DAO-TB
02-20

MODEL DAO

DO-ALL SERIES IVP PRESSURE
REDUCING REGULATORS
SMALL PISTON, PILOT OPERATED



MODEL DAO

OVERVIEW

Model DAO is a pilot-operated steam reducing regulator with a piston design. The internal pressure balanced plug/piston provides high flow capacity and moderate pressure drop capability. Applied as a steam service valve only. Maximum operating steam pressure is 250 psig (17.2 Barg) at 406°F (208°C).

FEATURES

- Versatile:** Two basic body materials to select from.
- Capacity:** High capacity. Allows smaller body sizes than competitors in majority of applications.
- Accuracy:** Pilot provides outlet pressure control to ± 2 psi.
- Trim Design:** "DO-ALL" trim design provides FTO and pressure balancing for higher inlet pressure. Results in unmatched sensitivity and stability. Internals are case-contained within easily removable quick change trim.
- Rangeability:** Basic valve gives outstanding rangeability due to close tolerances, balanced trim, and soft seats. Can be as high as 500:1.
- Heavy-Duty Guiding:** Both top and bottom guided to maintain stability and increased trim and seal life.
- Failure Position:** Fails closed on loss of pilot loading pressure. Fails open on loss of P₁ or P₂ pressures with loading pressure yet applied.



LINE SIZES AVAILABLE

1/2" (DN15), 3/4" (DN20), 1" (DN25),
1-1/4" (DN32), 1-1/2" (DN40), 2" (DN50),
2-1/2" (DN65), 3" (DN80), 4" (DN100)



END CONNECTIONS

NPT, FLANGED



COMMON APPLICATIONS

STEAM SERVICE



DESIGN PRESSURE

INLET: 35-400 psig (2.4-27.6 Barg)
OUTLET: 2-215 psig (0.13-14.8 Barg)

Алматы (7273)495-231
Ангарск (3955)60-70-56
Архангельск (8182)63-90-72
Астрахань (8512)99-46-04
Барнаул (3852)73-04-60
Белгород (4722)40-23-64
Благовещенск (4162)22-76-07
Брянск (4832)59-03-52
Владивосток (423)249-28-31
Владикавказ (8672)28-90-48
Владимир (4922)49-43-18
Волгоград (844)278-03-48
Волгодар (8172)26-41-59
Воронеж (473)204-51-73
Екатеринбург (343)384-55-89

Иваново (4932)77-34-06
Ижевск (3412)26-03-58
Иркутск (395)279-98-46
Казань (843)206-01-48
Калининград (4012)72-03-81
Калуга (4842)92-23-67
Кемерово (3842)65-04-62
Киров (8332)68-02-04
Коломна (4966)23-41-49
Кострома (4942)77-07-48
Краснодар (861)203-40-90
Красноярск (391)204-63-61
Курск (4712)77-13-04
Курган (3522)50-90-47
Липецк (4742)52-20-81

Магнитогорск (3519)55-03-13
Москва (495)268-04-70
Мурманск (8152)59-64-93
Набережные Челны (8552)20-53-41
Нижний Новгород (831)429-08-12
Ноябрьск (3496)41-32-12
Новокузнецк (3843)20-46-81
Новосибирск (383)227-86-73
Омск (3812)21-46-40
Орел (4862)44-53-42
Оренбург (3532)37-68-04
Пенза (8412)22-31-16
Петрозаводск (8142)55-98-37
Псков (8112)59-10-37
Пермь (342)205-81-47

Ростов-на-Дону (863)308-18-15
Рязань (4912)46-61-64
Самара (846)206-03-16
Санкт-Петербург (812)309-46-40
Саратов (845)249-38-78
Севастополь (8692)22-31-93
Саранск (8342)22-96-24
Симферополь (3652)67-13-56
Смоленск (4812)29-41-54
Сочи (862)225-72-31
Ставрополь (8652)20-65-13
Сургут (3462)77-98-35
Сыктывкар (8212)25-95-17
Тамбов (4752)50-40-97
Тверь (4822)63-31-35

Тольятти (8482)63-91-07
Томск (3822)98-41-53
Тула (4872)33-79-87
Тюмень (3452)66-21-18
Ульяновск (8422)24-23-59
Улан-Удэ (3012)59-97-51
Уфа (347)229-48-12
Хабаровск (4212)92-98-04
Чебоксары (8352)28-53-07
Челябинск (351)202-03-61
Череповец (8202)49-02-64
Чита (3022)38-34-83
Якутск (4112)23-90-97
Ярославль (4852)69-52-93

Россия +7(495)268-04-70

Казахстан +7(7172)727-132

Киргизия +996(312)96-26-47

STANDARD / GENERAL SPECIFICATIONS

Main Body / Cover Dome Materials

DI/DI, CS/CS.

DI = Ductile Iron CS = Carbon Steel

Main Body Sizes

1/2", 3/4", 1", 1-1/4", 1-1/2", 2", 2-1/2", 3", 4".
(DN15, 20, 25, 32, 40, 50, 65, 80, 100)

End Connections

Standard: Female NPT (screwed).
ASME Flanged: 125#, 150#, 250#, 300#;
DIN Flanged: PN16, PN25, PN40;
(Integral Flanged Body unless listed under Opt.-30)

Pilot Body / Spring or Loading Chamber Materials

CI/CI.

Pilot Body Size / End Connections

1/4" - NPT (DN6)

Tubing & Fittings

BR fittings, bite-type compression.
Cu (copper) tubing, refrigeration; 1/4" O.D. x 0.030" wall,
3/8" O.D. x 0.035" wall.

Pressure Drop Limits

Minimum: 35 psid (2.4 Bard)
Maximum: 225 psid (15.5 Bard)

Inlet Pressure Range

Operating: 35 - 400 psig (2.4 - 27.6 Barg)
See Table 1 for design P vs. T limits.

Outlet Pressure Range

Spring-Operated Pilot: 2 - 50 psig (.13 - 3.4 Barg)
10 - 200 psig (.69 - 13.8 Barg)
Pressure-Loaded Pilot: 2 - 215 psig (.13 - 14.8 Barg)

Max. Useable Cv

Body Size		Full Port Cv	Body Size		Full Port Cv
in	(DN)		in	(DN)	
1/2"	(15)	3.8	2"	(50)	57
3/4"	(20)	7.6	2-1/2"	(65)	85
1"	(25)	14.3	3"	(80)	114
1-1/4"	(32)	21.8	4"	(100)	209
1-1/2"	(40)	28.5			

Max. CAPACITY with PLUG WIDE OPEN

Body Size		Full Port Cv	Body Size		Full Port Cv
in	(DN)		in	(DN)	
1/2"	(15)	4.0	2"	(50)	60
3/4"	(20)	8.0	2-1/2"	(65)	90
1"	(25)	15	3"	(80)	120
1-1/4"	(32)	23	4"	(100)	220
1-1/2"	(40)	30			

Temperature Range

+100 to +406° F (+38 - +208° C)
Limited by DI/DI pilot materials only.

Inboard Leakage Rates

Class IV

Optional Constructions

Opt-30: Weld-on Flanges
Opt-56: Special Cleaned
Opt-85: Extra Set Pressure Taps

MATERIAL SPECIFICATIONS

Main Body

DI - ASTM A395
CS - ASTM A216, Gr. WCB.
See Table 1 for
Pressure - Temperature Ratings.

Main Cover Dome

DI - ASTM A395
CS - ASTM A216, Gr. WCB.

Pilot Body / Topworks

CI/CI - ASTM A395

Metallic Trim

17-4PH SST.

Seat

GF-TFE (Glass-fill TFE)

Static Seals

RTFE (Brz-fill TFE)

Dynamic Seals

PRA - GF-TFE + 316 SST energizer + GF-TFE Wiper

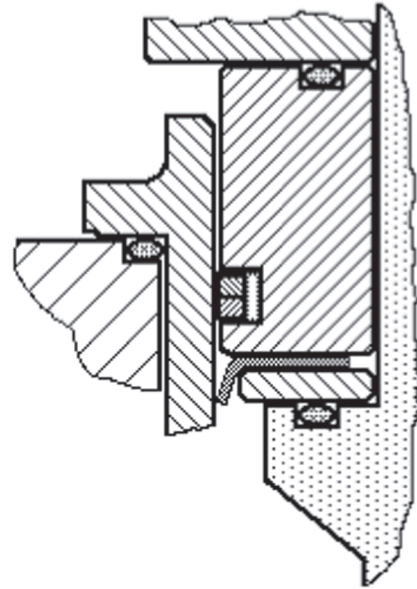

PRA DYNAMIC
SEAL + WIPER

Painting

Standard: All non-corrosion resistant portions to be painted with corrosion resistant epoxy paint per Cashco Spec #S-1606.

OPTION SPECIFICATIONS

OPT-30: **WELDED FLANGED CONNECTIONS.** CS body material only. 1/2" & 3/4" (DN15 & 20) body sizes only. Welded-on flange of same general chemistry as body.

OPT-56: **SPECIAL CLEANING.** Cleaning per Cashco Spec. #S-1542 for all body & cover dome materials. Higher cleaning level than standard commercial cleaning. NOT suitable for Oxygen Service.

Weld-On Flanges		
Sizes	Body Material	ASME Pressure Class
1/2" - 3/4"	CS	150, 300
Sizes	Body Material	ISO Pressure Class
DN15-50	CS	PN40 RF
DN65-100	CS	PN16, 25, 40 RF

OPT-85: **PRESSURE TAPS.** Provides a **second set** of inlet and outlet 1/4" - FNPT taps with plugs (same basic material as body) on backside of body. Includes second external sensing port tap. See page 6 for details on tap location for both STD and Opt-85.

NOTES: 1. The body P vs. T ratings are the limiting variables for flanged end connections, unless further restricted by ASME B16.5.
2. No post-weld stress relieving performed.

TABLE 1												
INLET & OUTLET PRESSURE vs. TEMPERATURE RATINGS												
INLET PRESSURE RATINGS												
Material- Body/ Cover Dome	Temperature		End Connection - Pressure Class - ASME									
			NPT		150#		300#		125#		250#	
	°F	°C	psig	Barg	psig	Barg	psig	Barg	psig	Barg	psig	Barg
DI/DI	-20 to +150	-29 to +65	400	27.6	NA	NA	NA	NA	200	13.8	400	27.6
	406	208	250	17.2	NA	NA	NA	NA	140	9.3	250	17.2
CS/CS	-20 to +150	-29 to +65	400	27.6	285	19.6	400	27.6	NA	NA	NA	NA
	406	208	250	17.2	200	13.8	250	17.2	NA	NA	NA	NA
OUTLET PRESSURE RATINGS												
Material- Body/ Cover Dome	Temperature		End Connection - Pressure Class - ASME									
			NPT		150#		300#		125#		250#	
	°F	°C	psig	Barg	psig	Barg	psig	Barg	psig	Barg	psig	Barg
DI/DI	-20 to +150	-29 to +65	400	27.6	NA	NA	NA	NA	200	13.8	400	27.6
	406	208	250	17.2	NA	NA	NA	NA	140	9.3	250	17.2
CS/CS	-20 to +150	-29 to +65	400	27.6	285	19.6	400	27.6	NA	NA	NA	NA
	406	208	250	17.2	200	13.8	250	17.2	NA	NA	NA	NA

Regulator with Pilot Assembly

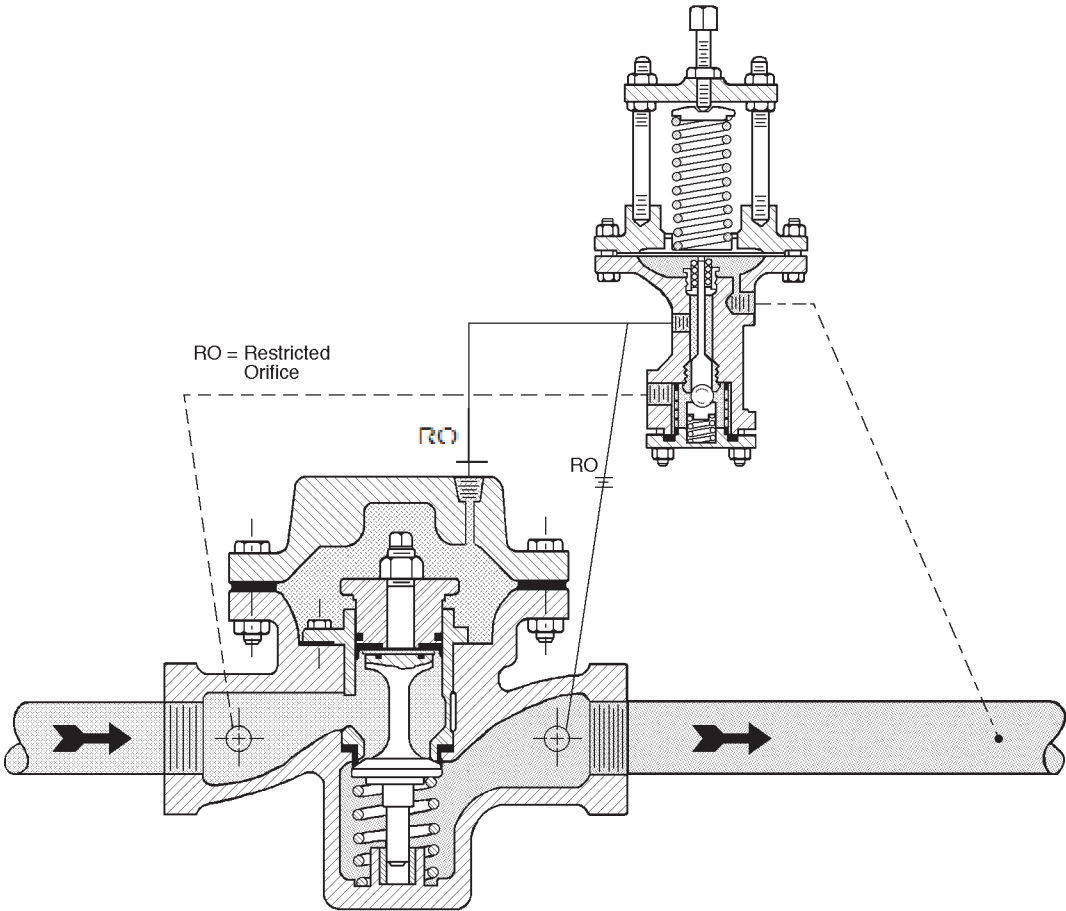

Location of BODY TAPS

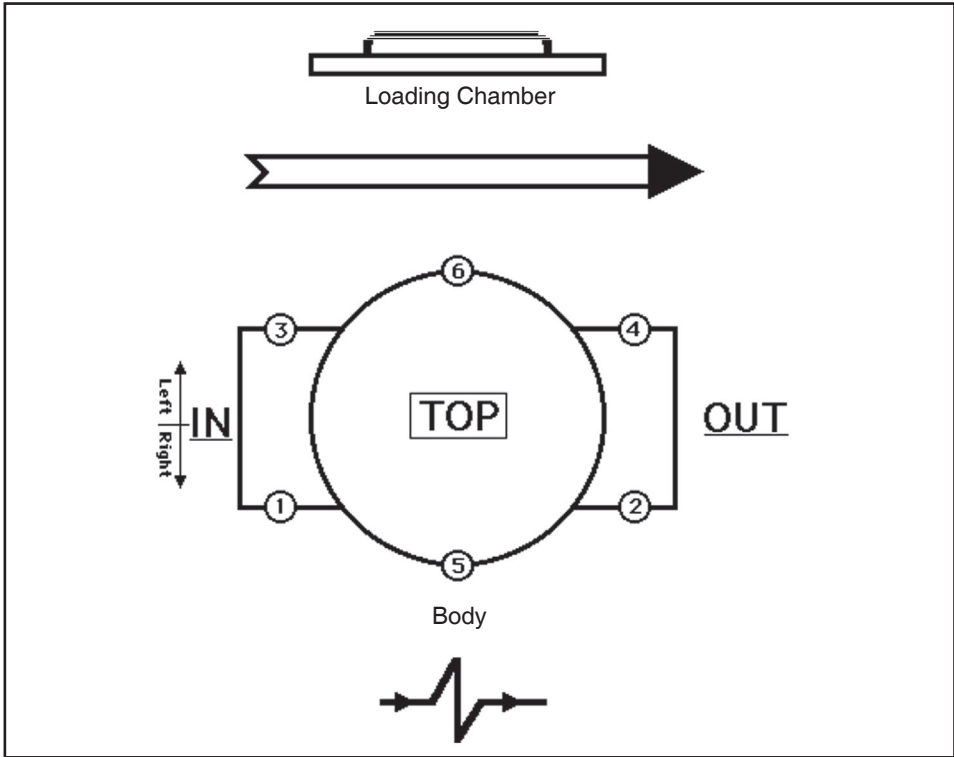

Flow To Open Direction

Location	Description	Opt. No.	NPT - Size	Body Mat'l.
1 & 2	Inlet & Outlet – Right	STD	1/4"	DI, & CS
5	External Sensing – Right	STD	1/4"	DI & CS
1, 2, 3 & 4	Inlet & Outlet – Right Inlet & Outlet – Left	85	1/4"	DI & CS
5 & 6	Double External Sensing	85	1/4"	DI, & CS

DIMENSION and WEIGHTS

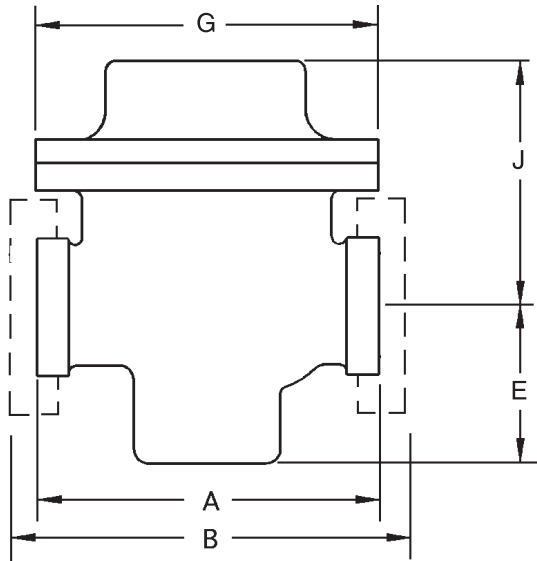

ENGLISH UNITS - (in)

Dimen.	End Conn.	Body Mat'l	Body Size					
			1/2", 3/4" & 1"	1-1/4" & 1-1/2"	2"	2-1/2"	3"	4"
A	NPT	DI	6.00	9.88	9.88			
		CS	8.25	9.88	9.75			
B	125# FF	DI				10.88	11.75	13.88
	250# RF					11.50	12.50	14.50
	150# RF	CS	10.75	12.38 *	10.00	10.88	11.75	13.88
	300# RF		10.75	12.38 *	10.50	11.50	12.50	14.50
E	ALL	DI	2.88	3.81	4.00	5.25	5.50	5.77
		CS	2.72	3.69	4.15	5.25	5.50	6.91
J	ALL	DI	4.67	5.35	5.69	7.90	9.38	9.39
		CS	4.58	5.39	5.80	7.75	9.56	9.42
G	ALL	DI	6.00	7.00	8.00	10.00	11.38	11.38
		CS	6.00	7.00	8.00	10.00	11.13	11.13
Approx. Weight lbs	wo/Flanges	ALL	23	32	48	-	-	-
	w/Flanges	ALL	28	42	61	90	155	164

METRIC UNITS - (mm)

Dimen.	End Conn.	Body Mat'l	Body Size					
			DN15, 20 & 25	DN32 & 40	DN50	DN65	DN80	DN100
A	NPT	DI	152	251	251			
		CS	210	251	247			
B	125# FF	DI				276	298	353
	250# RF					292	318	368
	150# RF	CS	273	314 *	254	276	298	353
	300# RF		273	314 *	267	292	318	368
E	ALL	DI	73	97	102	133	140	147
		CS	69	94	105	133	140	176
J	ALL	DI	119	136	145	201	238	239
		CS	116	137	147	197	243	239
G	ALL	DI	152	178	203	254	289	289
		CS	152	178	203	254	283	283
Approx. Weight kgs	wo/Flanges	ALL	10	14	22	-	-	-
	w/Flanges	ALL	12	19	28	41	70	74

* Flanged Connections Not available for 1-1/4" (DN32) size.

The contents of this publication are presented for informational purposes only, and while every effort has been made to ensure their accuracy, they are not to be construed as warranties or guarantees, express or implied, regarding the products or services described herein or their use or applicability. We reserve the right to modify or improve the designs or specifications of such product at any time without notice.

Cashco, Inc. does not assume responsibility for the selection, use or maintenance of any product. Responsibility for proper selection, use and maintenance of any Cashco, Inc. product remains solely with the purchaser.

MODEL DA0 PRODUCT CODER 02/07/20

An "X" in POS 12 followed by a 5-digit control number overrides remaining selections.

D0 POS 3 — POS 5 **PG7** — POS 10 **3** POS 12 POS 13 **C** POS 15 POS 16 **OE**

POSITION 3 - SIZE		
Size		CODE
In	(DN)	
1/2"	(15)	4
3/4"	(20)	5
1"	(25)	6
1-1/4"	(32)	7
1-1/2"	(40)	8
2"	(50)	9
2-1/2"	(65)	A
3"	(80)	B
4"	(100)	C

POSITION 5 - BODY/ COVER DOME MATERIALS	
Materials	CODE
DI/DI	1
CS/CS	5

SEAT/SEAL MATERIALS				
Trim Material	O-ring/Seal			CODE
	Seat	Static	Dynamic	
17-4PH SST "P"	GF-TFE	RTFE	PRA + W	PG

POSITION 10 - END CONNECTIONS / ASME								
Size	Material	Method	End Conn	CODE	End Conn	CODE	End Conn	CODE
1/2" - 2"	ALL	-	NPT	1	-	-		
2-1/2" - 4"	DI	Integral	125#FF	2	250#RF	3		
1/2" - 3/4"	CS	Opt-30	150#RF	4	300#RF	5		
1" - 4"	CS	Integral *						
END CONNECTIONS FOR ISO DIN FLANGES								
DN15-25, 40, 50	CS	Opt-30	PN40 RF - will mate with PN16, 25 and 40					D
DN65-100	CS	Integral	PN16 RF	A	PN25 RF	C	PN40 RF	G

* Flanged Connections Not available for 1-1/4" (DN32) size.

POSITION 12 - PILOT VALVE TYPE / MATERIALS		
Spring Loaded		
Type No.	Body Mat'l.	CODE
90SO	CI	1
Pressure Loaded		
90MA6 1:1	CI	B
90MD6 1:3		C
90MA7 1:6		D
For Special Construction Contact Cashco for Special Code		X

POSITION 13 - RANGE SPRINGS	
Spring Range	CODE
Pressure Loaded	0
2-50 psig (.13 - 3.4 Barg)	A
10-200 psig (.69 - 13.8 Barg)	B

POSITION 15 - BODY OPTIONS		Option	CODE
No Option		-	0
Second "Set" of 1/4" (DN8) FNPT Pressure Taps & Plugs.		-85	T

POSITION 16 - CERTIFICATE OPTIONS		Option	CODE
No Option		-	0
SPECIAL CLEANING: Per Cashco Spec #S-1542.		-56	N

Алматы (7273)495-231
 Ангарск (3955)60-70-56
 Архангельск (8182)63-90-72
 Астрахань (8512)99-46-04
 Барнаул (3852)73-04-60
 Белгород (4722)40-23-64
 Благовещенск (4162)22-76-07
 Брянск (4832)59-03-52
 Владивосток (4231)249-28-31
 Владикавказ (8672)28-90-48
 Владимир (4922)49-43-18
 Волгоград (844)278-03-48
 Вологда (8172)26-41-59
 Воронеж (473)204-51-73
 Екатеринбург (343)384-55-89

Иваново (4932)77-34-06
 Ижевск (3412)26-03-58
 Иркутск (395)279-98-46
 Казань (843)206-01-48
 Калининград (4012)72-03-81
 Калуга (4842)92-23-67
 Кемерово (3642)65-04-62
 Киров (8332)68-02-04
 Коломна (4966)23-41-49
 Кострома (4942)77-07-48
 Краснодар (861)203-40-90
 Красноярск (391)204-63-61
 Курск (4712)77-13-04
 Курган (3522)50-90-47
 Липецк (4742)52-20-81

Магнитогорск (3519)55-03-13
 Москва (495)268-04-70
 Мурманск (8152)59-64-93
 Набережные Челны (8552)20-53-41
 Нижний Новгород (831)429-08-12
 Новокузнецк (3843)20-46-81
 Ноябрьск (3496)41-32-12
 Новосибирск (383)227-86-73
 Омск (3812)21-46-40
 Орел (4862)44-53-42
 Оренбург (3532)37-68-04
 Пенза (8412)22-31-16
 Петрозаводск (8142)55-98-37
 Псков (8112)59-10-37
 Пермь (342)205-81-47

Ростов-на-Дону (863)308-18-15
 Рязань (4912)46-61-64
 Самара (846)206-03-16
 Санкт-Петербург (812)309-46-40
 Саратов (845)249-38-78
 Севастополь (8692)22-31-93
 Саранск (8342)22-96-24
 Симферополь (3652)67-13-56
 Смоленск (4812)29-41-54
 Сочи (862)225-72-31
 Ставрополь (8652)20-65-13
 Сургут (3462)77-98-35
 Сыктывкар (8212)25-95-17
 Тамбов (4752)50-40-97
 Тверь (4822)63-31-35

Тольятти (8482)63-91-07
 Томск (3822)98-41-53
 Тула (4872)33-79-87
 Тюмень (3452)66-21-18
 Ульяновск (8422)24-23-59
 Улан-Удэ (3012)59-97-51
 Уфа (347)229-48-12
 Хабаровск (4212)92-98-04
 Чебоксары (8352)28-53-07
 Челябинск (351)202-03-61
 Черовец (8202)49-02-64
 Чита (3022)38-34-83
 Якутск (4112)23-90-97
 Ярославль (4852)69-52-93

Россия +7(495)268-04-70

Казахстан +7(7172)727-132

Киргизия +996(312)96-26-47

<https://cashco.nt-rt.ru/> || coc@nt-rt.ru