



ISO Registered Company

P7-TB

03-22

# MODEL P7

HIGH FLOW  
HIGH SENSITIVITY  
PRESSURE REDUCING  
REGULATOR



MODEL P7

## OVERVIEW

The Model P7 is designed to safely reduce inlet pressures of up to 4500 psig (310.0 Barg)\* and accurately deliver high gas flows throughout the 10-1500 psig (.69-103.4 Barg) outlet pressure range. Designed for control of high and low pressure gases, this self-venting unit can also be furnished as a non-venting regulator for hydraulic applications.

## FEATURES

- Large Piston Sensor Gives Excellent Sensitivity
- Balanced Stem Design Assuring Constant Downstream Pressure
- Low Operating Torque
- Self-Relieving (Spring Loaded Design)
- Anti-Resonance Design

## TYPICAL APPLICATIONS

The P7 can be applied for hyperbaric chambers, air compressors, pressurized ballast tanks, high pressure testing, life support applications, manifold systems, tube trailers, and gas transfer stations.



## LINE SIZES AVAILABLE

1/2" (DN15), 3/4" (DN20)



## END CONNECTIONS

FNPT, RAISED FACED FLANGED



## COMMON APPLICATIONS

HYPERBARIC CHAMBERS, AIR COMPRESSORS, PRESSURIZED BALLAST TANKS, HIGH PRESSURE TESTING, LIFE SUPPORT APPLICATIONS, MANIFOLD SYSTEMS, TUBE TRAILERS, GAS TRANSFER STATIONS



## DESIGN PRESSURE

INLET: UP TO 4,500 psig (310.3 Barg)  
OUTLET: 10-1500 psig (0.69-103.4 Barg)

Алматы (7273)495-231  
Ангарск (3955)60-70-56  
Архангельск (8182)63-90-72  
Астрахань (8512)99-46-04  
Барнаул (3852)73-04-60  
Белгород (4722)40-23-64  
Благовещенск (4162)22-76-07  
Брянск (4832)59-03-52  
Владивосток (423)249-28-31  
Владикавказ (8672)28-90-48  
Владимир (4922)49-43-18  
Волгоград (844)278-03-48  
Вологда (8172)26-41-59  
Воронеж (473)204-51-73  
Екатеринбург (343)384-55-89

Иваново (4932)77-34-06  
Ижевск (3412)26-03-58  
Иркутск (395)279-98-46  
Казань (843)206-01-48  
Калининград (4012)72-03-81  
Калуга (4842)92-23-67  
Камерово (3842)65-04-62  
Киров (8332)68-02-04  
Коломна (4966)23-41-49  
Кострома (4942)77-07-48  
Краснодар (861)203-40-90  
Красноярск (391)204-63-61  
Курск (4712)77-13-04  
Курган (3522)50-90-47  
Липецк (4742)52-20-81

Магнитогорск (3519)55-03-13  
Москва (495)268-04-70  
Мурманск (8152)59-64-93  
Набережные Челны (8552)20-53-41  
Нижний Новгород (831)429-08-12  
Новокузнецк (3843)20-46-81  
Новыйбратск (3496)41-32-12  
Новосибирск (383)227-86-73  
Омск (3812)21-46-40  
Орел (4862)44-53-42  
Оренбург (3532)37-68-04  
Пенза (8412)22-31-16  
Петрозаводск (8142)55-98-37  
Псков (8112)59-10-37  
Пермь (342)205-81-47

Ростов-на-Дону (863)308-18-15  
Рязань (4912)46-61-64  
Самара (846)206-03-16  
Санкт-Петербург (812)309-46-40  
Саратов (845)249-38-78  
Севастополь (8662)22-31-93  
Саранск (8342)22-96-24  
Симферополь (3652)67-13-56  
Смоленск (4812)29-41-54  
Сочи (862)225-72-31  
Ставрополь (8652)20-65-13  
Сургут (3462)77-98-35  
Сыктывкар (8212)25-95-17  
Тамбов (4752)50-40-97  
Тверь (4822)63-31-35

Тольятти (8482)63-91-07  
Томск (3822)98-41-53  
Тула (4872)33-79-87  
Тюмень (3452)66-21-18  
Ульяновск (8422)24-23-59  
Улан-Удэ (3012)59-97-51  
Уфа (347)229-48-12  
Хабаровск (4212)92-98-04  
Чебоксары (8352)28-53-07  
Челябинск (351)202-03-61  
Череповец (8202)49-02-64  
Чита (3022)38-34-83  
Якутск (4112)23-90-97  
Ярославль (4852)69-52-93

Россия +7(495)268-04-70

Казахстан +7(7172)727-132

Киргизия +996(312)96-26-47

# GENERAL SPECIFICATIONS

**Inlet & Outlet Port Size:** 1/2" and 3/4" (DN15 and DN20)

**Cv Capability:** 2 Cv

**\* Maximum Inlet Pressure:**  
**Brass** 3,750 psig (258.6 Barg)  
**Stainless** 4,500 psig (310.3 Barg)  
 See Table 1.

**Design Leakage:** ANSI/FCI 70-3 Class VI

**Outlet Pressure:** 10-1500 psig (.69-103.4 Barg)

**Body End Connections:** FNPT in Brass or SST, 300#, 600#, 1500#RF Flanges in SST.

**Body and Spring Chamber Material:** 316L SST/316L SST - ASTM A479 Brass/Brass - ASTM B16 C36000

**Operating Temp. Range:** 0 to 400°F (-17 to 204°C)

**Internal Volume:** 1.77 in<sup>3</sup> (29 cm<sup>3</sup>)

**TABLE 1  
 MODEL P7 DESIGN PRESSURE VS TEMPERATURE  
 NPT RATINGS PER ASME B31.3; FLANGE RATINGS PER ASME B16.5**

Body and Spring Chamber Material	End Connection	Temperature		Inlet Pressure		Outlet Pressure	
		°F	(°C)	psig	(Barg)	psig	(Barg)
Brass * ASME B16 C36000	NPT	-325 to +165	(-198 to +74)	3750	(258)	1500	(103)
		200	(93)	3680	(253)	1470	(101)
		300	(149)	3520	(242)	1380	(95.1)
		400	(200)	3355	(231)	1235	(85.1)
Stainless Steel ** ASTM A479 S31600/S31603	NPT	-425 to +300	(-254 to +149)	4500	(310)	1500	(103)
		400	(204)	4340	(299)	1445	(99.6)
		500	(260)	4025	(277)	1340	(92.4)
		600	(316)	3825	(263)	1275	(87.9)
		700	(371)	3665	(252)	1220	(84.1)
		800	(425)	3575	(246)	1190	(82.0)
	Class 300 RF Flanged	-425 to +100	(-254 to +38)	720	(49.6)	720	(49.6)
		200	(93)	620	(42.7)	620	(42.7)
		300	(149)	560	(38.6)	560	(38.6)
		400	(204)	515	(35.5)	515	(35.5)
		500	(260)	480	(33.1)	480	(33.1)
		600	(316)	450	(31.0)	450	(31.0)
		700	(371)	435	(30.0)	435	(30.0)
	Class 600 RF Flanged	-425 to +100	(-254 to +38)	1440	(99.3)	1440	(99.3)
		200	(93)	1240	(85.5)	1240	(85.5)
		300	(149)	1120	(77.2)	1120	(77.2)
		400	(204)	1025	(70.6)	1025	(70.6)
		500	(260)	955	(65.8)	955	(65.8)
		600	(316)	900	(62.0)	900	(62.0)
		700	(371)	870	(60.0)	870	(60.0)
	Class 1500 RF Flanged	-425 to +100	(-254 to +38)	3600	(248)	1500	(103)
		200	(93)	3095	(213)	1500	(103)
		300	(149)	2795	(192)	1500	(103)
		400	(204)	2570	(177)	1445	(99.6)
		500	(260)	2390	(164)	1340	(92.4)
		600	(316)	2255	(155)	1275	(87.9)
		700	(371)	2170	(149)	1220	(84.1)
	800	(425)	2110	(145)	1190	(82.0)	

\* Design pressure/temperature rating shall not exceed 3000 psig (206.8 Barg) and 400°F (200°C) when body material is brass and process medium is oxygen (CGA G-4.4)

\*\* Design pressure/temperature rating shall not exceed 375 psig (26 Barg) and 400°F (200°C) when the process medium is oxygen (CGA G-4.4).

## OPTIONS

**NACE Construction** - Internal wetted portions meet NACE standard MR0175, when the exterior of the regulator is not directly exposed to a sour gas environment, buried, insulated or otherwise denied direct atmospheric exposure. Available in 316L SST/316L SST body and spring chamber materials only. Requires non-relieving construction option when spring loaded design is selected.

**Panel Mount** - Includes a panel nut that allows the spring chamber and control knob to be secured through a panel wall. Requires 1/8" minimum panel thickness and 2" diameter hole. Note available with dome loaded or ratio loaded options.

**Non-Relieving Construction - Spring Loaded Design** - The self relieving components are removed to prevent vapor discharge to atmosphere when decreasing pressure settings.

**Cleaned for Oxygen Service #S-1134** - Cashco cleaning specification that is required for gaseous oxygen service. This specification is compliant with CGA G-4.4 and includes sealed enclosure bag and notification tag stating suitability for gaseous oxygen service. See notes Table 1 for ratings restrictions.

**Cleaned per Spec. #S-1542** - Cashco cleaning specification similar to S-1134 that includes sealed enclosure bag and notification tag stating suitability for non-oxygen service.

**Cleaned for Hydrogen Service #S-1821** - Cashco cleaning specification that is required for gaseous hydrogen service. This specification is compliant with CGA G-5.4 and includes sealed enclosure bag and notification tag stating suitability for gaseous hydrogen service. Installation is limited to non-enclosed environments as the Model P7 does not have a captured spring chamber design.

**Outlet Gauge Port** - Includes a single 1/4" NPT outlet gauge port located at 130° per the porting configuration guide.

**Flanged End Connections** - Includes raised face flanged end connections for ASME 300, 600, and 1500 pressure classes. Available for 316L stainless steel body material for inlet and outlet connections only. 14" (356 mm) face to face dimension.

**Pneumatic Dome Loaded** - The pneumatic dome loaded option replaces the standard spring chamber, range spring, adjusting screw, and knob with a cover dome that uses a pneumatic signal for actuation. This allows for regulator pressure settings to be adjusted from a remote location. Not available for use with panel mount option.

**Pneumatic Ratio Loaded** - The pneumatic ratio loaded option replaces the standard spring chamber, range spring, adjusting screw, and knob with an actuator that uses a pneumatic signal for actuation. The large actuator area (19:1 ratio) allows the user to achieve outlet pressures up to 1500 Psig (Barg) with loading pressures up to 80 Psig (5.5 Barg). In addition, this allows for regulator pressure settings to be adjusted from a remote location. Not available for use with panel mount option.

**DIMENSIONS AND WEIGHTS**

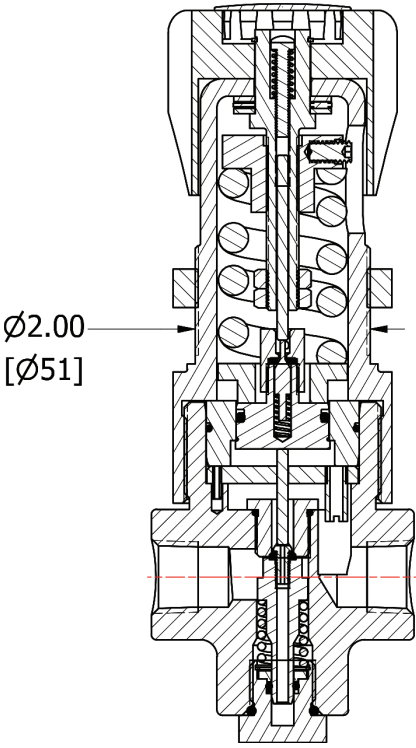

**PANEL MOUNT**

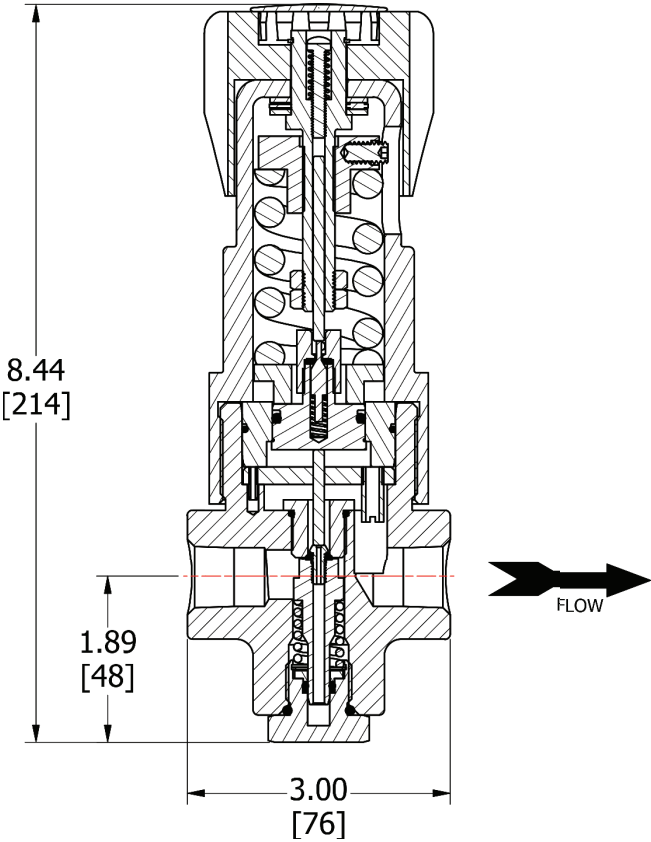

**STANDARD**

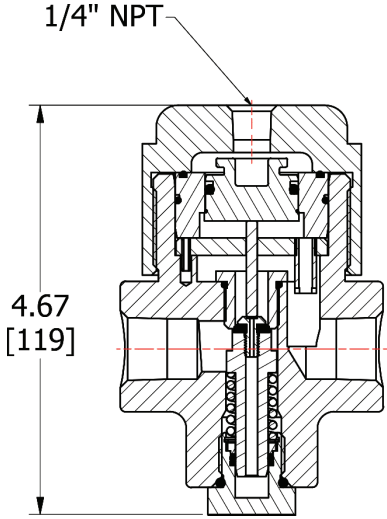

**DOME LOADED**

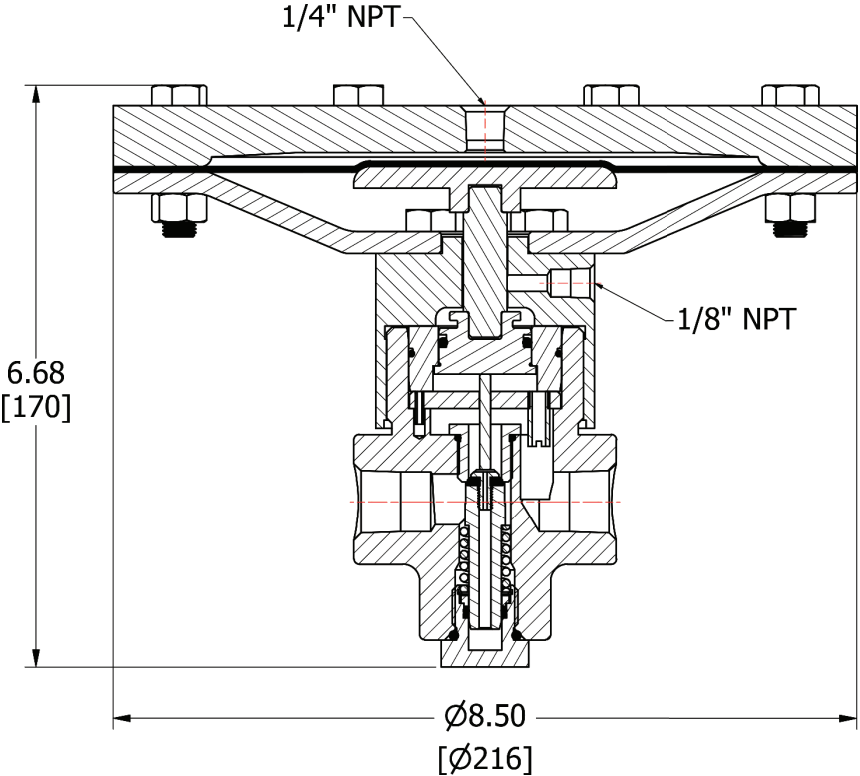

**RATIO LOADED**

## DIMENSIONS AND WEIGHTS

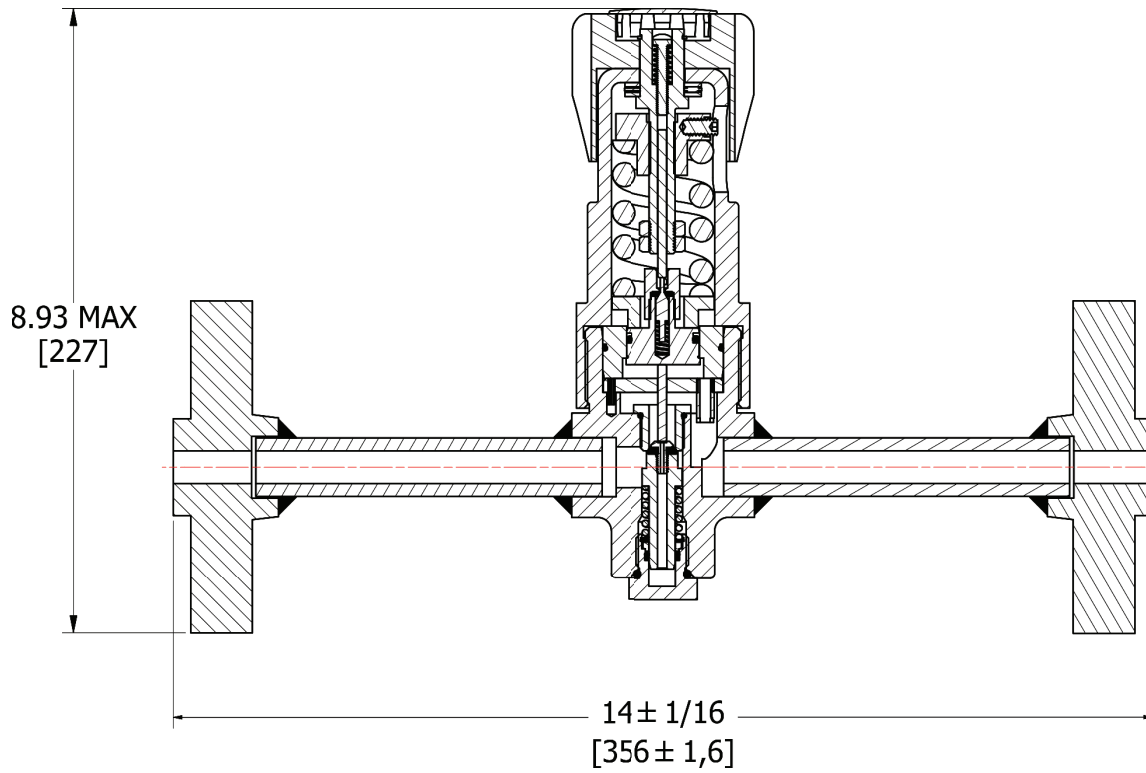

### **FLANGED END CONNECTIONS**

MAXIMUM WEIGHT ESTIMATES		
UNITS	NON-FLANGED	FLANGED
lb	7.5	26
(kg)	(-3.4)	(-11.8)

## HIGH FLOW / HIGH PRESSURE FLOW CHARTS

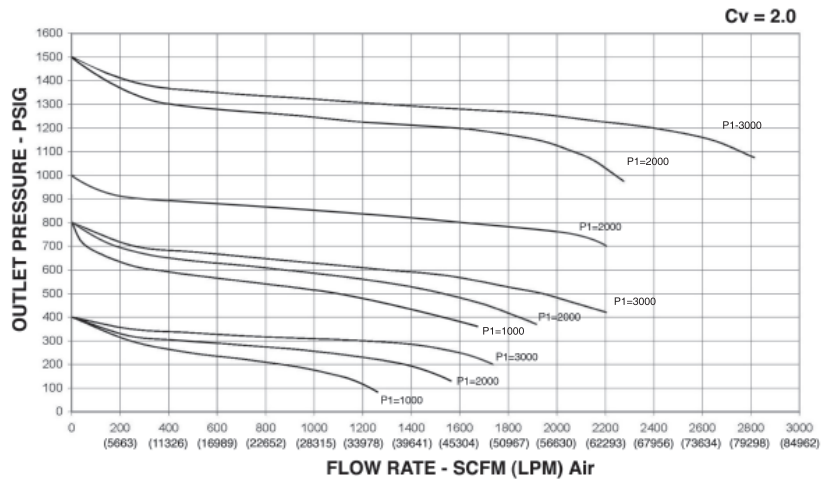
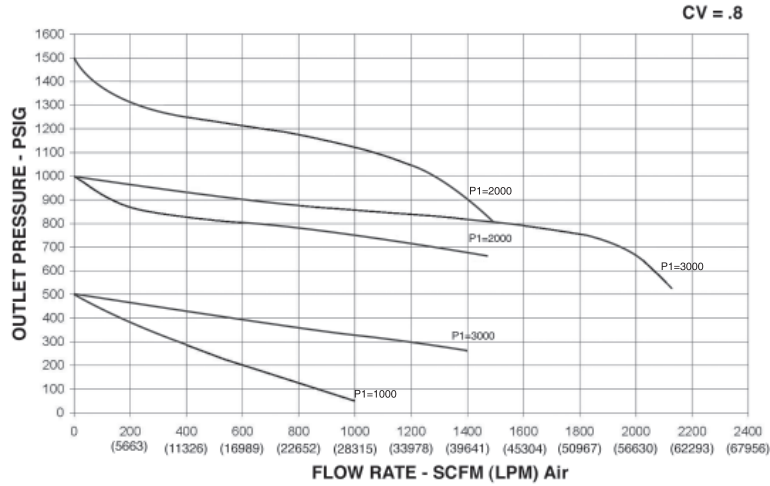

## PORTING CONFIGURATION GUIDE

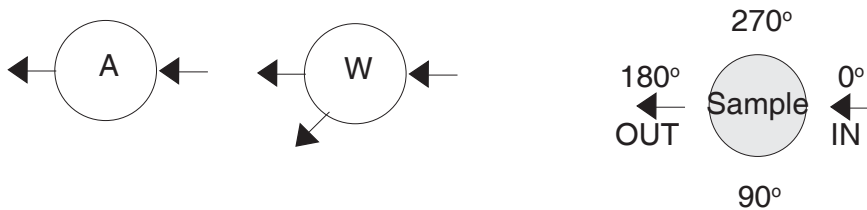

The contents of this publication are presented for informational purposes only, and while every effort has been made to ensure their accuracy, they are not to be construed as warranties or guarantees, express or implied, regarding the products or services described herein or their use or applicability. We reserve the right to modify or improve the designs or specifications of such product at any time without notice. Cashco, Inc. does not assume responsibility for the selection, use or maintenance of any product. Responsibility for proper selection, use and maintenance of any Cashco, Inc. product remains solely with the purchaser.

**MODEL P7 PRODUCT CODER** 03/31/22

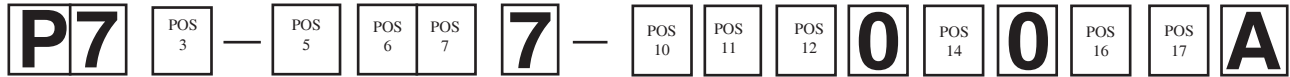

POSITION 3 - BODY SIZE/Cv		
Size	Cv	CODE
1/2" (DN15)	0.8	2
	2.0	3
3/4" (DN20)	0.8	5
	2.0	6

POSITION 5 - BODY/SPRING CHAMBER	
Body/Spring Chamber Mat'l.	CODE
316L SST/316L SST	S
Brass/Brass	B

POSITION 6 - SEAT MATERIALS				
Outlet	Main Valve	Vent Valve	Std	NACE
			CODE	CODE
300 Psig (20.7 Barg)	TFE	CTFE	1	5
600 Psig (41.4 Barg)	TFE	CTFE	2	6
1000 Psig (69.0 Barg)	TFE	CTFE	3	7
1500 Psig (103.0 Barg)	TFE	CTFE	4	8

POSITION 7 - PORTING CONFIGURATION	
Description	CODE
No Outlet Gauge Port	A
Outlet Gauge Port Included	W

POSITION 10 - END CONNECTIONS	
End Connection(s)	CODE
FNPT	1
300 # RF Flange	7
600 # RF Flange	8
1500 # RF Flange	A

POSITION 11 - RANGE SPRING/OUTLET PRESSURE		
DESIGN CONFIGURATION	OUTLET PRESSURE psig (Barg)	CODE
Ratio Loaded 19 : 1	10 - 1500 (0.69 - 103.0)	A
Pneumatic Dome Loaded	10 - 1500 (0.69 - 103.0)	0
Spring Loaded	10 - 300 (0.69 - 20.7)	2
Spring Loaded	15 - 600 (1.0 - 41.3)	3
Spring Loaded	20 - 1000 (1.4 - 69.0)	5
Spring Loaded	50 - 1500 (3.4 - 103.4)	6

POSITION 12 - OUTLET GAUGE (See "NOTE" - Position 7)	
Psig (Barg)	CODE
0 - 100 (0 - 6.9)	D
0 - 160 (0 - 11.0)	E
0 - 300 (0 - 20.7)	F
0 - 600 (0 - 41.3)	G
0 - 1000 (0 - 69.0)	H
0 - 2000 (0 - 138.0)	J
No Outlet Gauge	0

POSITION 14 - OPTIONS			
OPTIONS	CODE	OPTIONS	CODE
No Option	0	Panel Mount.	C

POSITION 16 - OPTIONS			
OPTIONS	CODE	OPTIONS	CODE
No Option	0	Non-Relieving Construction for Spring Loaded Design.	6

POSITION 17 - OPTIONS	
OPTIONS	CODE
No Cleaning Specification	0
Cleaned for Oxygen Service Per Cashco Specification S-1134	M
Cleaned for Non-Oxygen Service Per Cashco Specification S-1542	N
Cleaned for Hydrogen Service Per Cashco Specification S-1821	R

Алматы (7273)495-231  
 Ангарск (3955)60-70-56  
 Архангельск (8182)63-90-72  
 Астрахань (8512)99-46-04  
 Барнаул (3852)73-04-60  
 Белгород (4722)40-23-64  
 Благовещенск (4162)22-76-07  
 Брянск (4832)59-03-52  
 Владивосток (423)249-28-31  
 Владикавказ (8672)28-90-48  
 Владимир (4922)49-43-18  
 Волгоград (844)278-03-48  
 Вологда (8172)26-41-59  
 Воронеж (473)204-51-73  
 Екатеринбург (343)384-55-89

Иваново (4932)77-34-06  
 Ижевск (3412)26-03-58  
 Иркутск (395)279-98-46  
 Казань (843)206-01-48  
 Калининград (4012)72-03-81  
 Калуга (4842)92-23-67  
 Кемерово (3842)65-04-62  
 Киров (8332)68-02-04  
 Коломна (4966)23-41-49  
 Кострома (4942)77-07-48  
 Краснодар (861)203-40-90  
 Красноярск (391)204-63-61  
 Курск (4712)77-13-04  
 Курган (3522)50-90-47  
 Липецк (4742)52-20-81

Магнитогорск (3519)55-03-13  
 Москва (495)268-04-70  
 Мурманск (8152)59-64-93  
 Набережные Челны (8552)20-53-41  
 Нижний Новгород (831)429-08-12  
 Новокузнецк (3843)20-46-81  
 Ноябрьск (3496)41-32-12  
 Новосибирск (383)227-86-73  
 Омск (3812)21-46-40  
 Орел (4862)44-53-42  
 Оренбург (3532)37-68-04  
 Пенза (8412)22-31-16  
 Петрозаводск (8142)55-98-37  
 Псков (8112)59-10-37  
 Пермь (342)205-81-47

Ростов-на-Дону (863)308-18-15  
 Рязань (4912)46-61-64  
 Самара (846)206-03-16  
 Санкт-Петербург (812)309-46-40  
 Саратов (845)249-38-78  
 Севастополь (8692)22-31-93  
 Серанск (8342)22-96-24  
 Симферополь (3652)67-13-56  
 Смоленск (4812)29-41-54  
 Сочи (862)225-72-31  
 Ставрополь (8652)20-65-13  
 Сургут (3462)77-98-35  
 Сыктывкар (8212)25-95-17  
 Тамбов (4752)50-40-97  
 Тверь (4822)63-31-35

Тольятти (8482)63-91-07  
 Томск (3822)98-41-53  
 Тула (4672)33-79-87  
 Тюмень (3452)66-21-18  
 Ульяновск (8422)24-23-59  
 Улан-Удэ (3012)59-97-51  
 Уфа (347)229-48-12  
 Хабаровск (4212)92-98-04  
 Чебоксары (8352)28-53-07  
 Челябинск (351)202-03-61  
 Череповец (8202)49-02-64  
 Чита (3022)38-34-83  
 Якутск (4112)23-90-97  
 Ярославль (4852)69-52-93

Россия +7(495)268-04-70

Казахстан +7(7172)727-132

Киргизия +996(312)96-26-47

<https://cashco.nt-rt.ru/> || [coc@nt-rt.ru](https://coc@nt-rt.ru)