



ISO Registered Company

P2-TB
02-20



MODEL P2

MODEL P2

SINGLE STAGE CYLINDER GAS PRESSURE REDUCING REGULATOR

OVERVIEW

The Model P2 is designed for gases with inlet pressures up to 3600 psig (248 Barg). Standard adjustable outlet ranges from 1-10 psig (.07-.69 Barg) thru 10-750 psig (.69-51.7 Barg). Flow coefficient of 0.02, 0.06, and 0.20 available. This versatile cylinder gas regulator can be ordered with a variety of options to meet your system demands. Standard construction includes 40 micron integral filter and diffusion resistant stainless steel diaphragm. Gauges and CGA fitting is optional.

TYPICAL APPLICATIONS

- Cylinder Gas
- Calibration Gas
- Laser Gas
- Medical Gas

FUNCTIONAL PERFORMANCE

Supply Pressure Effect	0.5/100 psig (0.03/6.9 Barg)
Temperature Coefficient	0.16 psig/°F (0.01 Barg/ °C)
Design Proof Pressure	150% of Max Operating Pressure
Pressure	5,400 psig (372.3 Barg)
Internal Volume	6.9 cc



LINE SIZES AVAILABLE
1/4" (DN8), 3/8" (DN10), 1/2" (DN15)



END CONNECTIONS
FNPT, CGA



COMMON APPLICATIONS
CYLINDER GAS, CALIBRATION GAS, LASER GAS, MEDICAL GAS



DESIGN PRESSURE
INLET: UP TO 3600 psig (248.2 Barg)
OUTLET: 1-750 psig (0.07-51.7 Barg)

Алматы (7273)495-231
Ангарск (3955)60-70-56
Архангельск (8182)63-90-72
Астрахань (8512)99-46-04
Барнаул (3852)73-04-60
Белгород (4722)40-23-64
Благовещенск (4162)22-76-07
Брянск (4832)59-03-52
Владивосток (423)249-28-31
Владикавказ (8672)28-90-48
Владимир (4922)49-43-18
Волгоград (841)278-03-48
Вологда (8172)26-41-59
Воронеж (473)204-51-73
Екатеринбург (343)384-55-89

Иваново (4932)77-34-06
Ижевск (3412)26-03-58
Иркутск (395)279-98-46
Казань (843)206-01-48
Калининград (4012)72-03-81
Калуга (4842)92-23-67
Кемерово (3842)65-04-62
Киров (8332)68-02-04
Коломна (4966)23-41-49
Кострома (4942)77-07-48
Краснодар (861)203-40-90
Красноярск (391)204-63-61
Курск (4712)77-13-04
Курган (3522)50-90-47
Липецк (4742)52-20-81

Магнитогорск (3519)55-03-13
Москва (495)268-04-70
Мурманск (8152)59-64-93
Набережные Челны (8552)20-53-41
Нижний Новгород (831)429-08-12
Новокузнецк (3843)20-46-81
Ноябрьск (3496)41-32-12
Новосибирск (383)227-86-73
Омск (3812)21-46-40
Орел (4862)44-53-42
Оренбург (352)37-68-04
Пенза (8412)22-31-16
Петрозаводск (8142)55-98-37
Псков (8112)59-10-37
Пермь (342)205-81-47

Ростов-на-Дону (863)308-18-15
Рязань (4912)46-61-64
Самара (846)206-03-16
Санкт-Петербург (812)309-46-40
Саратов (845)249-38-78
Севастополь (8692)22-31-93
Саранск (8342)22-96-24
Симферополь (3652)67-13-56
Смоленск (4812)29-41-54
Сочи (862)225-72-31
Ставрополь (8652)20-65-13
Сургут (3462)77-98-35
Сыктывкар (8212)25-95-17
Тамбов (4752)50-40-97
Тверь (4822)63-31-35

Тольятти (8482)63-91-07
Томск (3822)98-41-53
Тула (4872)33-79-87
Тюмень (3452)66-21-18
Ульяновск (8422)24-23-59
Улан-Удэ (3012)59-97-51
Уфа (347)229-48-12
Хабаровск (4212)92-98-04
Чебоксары (8352)28-53-07
Челябинск (351)202-03-61
Череповец (8202)49-02-64
Чита (3022)98-34-83
Якутск (4112)23-90-97
Ярославль (4852)69-52-93

Россия +7(495)268-04-70

Казахстан +7(7172)727-132

Киргизия +996(312)96-26-47

GENERAL SPECIFICATIONS

Inlet/Outlet Size:	1/4", 3/8" & 1/2" (DN8, DN10 & DN15)	Wetted Material Temp. Limits:	See Coder Position 6.
Maximum Inlet Pressure:	3,600 psig (248.2 Barg) Min. Pressure drop 100 psid.	PCTFE Polyimide TFE	-45 to 185°F (-42.7 to 85°C) -45 to 575°F (-42.7 to 301°C) -45 to 275°F (-42.7 to 135°C)
Outlet Pressure:	1-750 psig (.07-.51.7 Barg)	Operating Temp. Range:	
Body End Connections:	FNPT, CGA End Connection	Brass - SST -	-20 to 400°F (-28.9 to 204°C) -20 to 500°F (-28.9 to 260°C)
Body and Spring Chamber Material:	316L SST/316 SST Brass/6061 AL Brass/316L SST	Composite Knob: (Standard)	-50 to 200°F (-45.6 to 93°C) For temperatures outside (Std.) knob range see Options for Colored Knobs.

STANDARD CONSTRUCTION

Captured Vent

The captured vent feature is designed to safely vent process fluid when handling toxic or hazardous media. The user can easily pipe this vent to a safe location. It features a 1/8" FNPT port located on the spring housing. This feature can be incorporated into a self-relieving regulator that provides an additional port to permit the piping away of the expelled media.

OPTIONS

NACE Construction - (P or R) in Position 6. - Internal wetted portions meet NACE standard MR0175, when the exterior of the regulator is not directly exposed to a sour gas environment, buried, insulated or otherwise denied direct atmospheric exposure. SST/SST body/spring chamber materials only. Inconel w/TFE liner, Inconel X-750 spring.

Dome Loaded - (0) in Position 11. - The dome loaded option allows for regulators to be loaded from remote location to change pressure settings. **NOTES:** Diaphragm failure will result in loading fluid to mix with the process being controlled. Maximum Loading Pressure is 125 psig (8.6 Barg). Not available with self-relieving constructions.

Mounting Bracket - (5) in Position 14. - The mounting bracket is a base, or step type. The material is 303 stainless steel. The bracket mounts to the back of the single stage, and back pressure regulators, via 10/32 screws.

Panel Mount - (C) in Position 14. - The panel mount feature requires a panel minimum of 11 gauge (.12) thick with a 1-3/8" hole cut out, complete with a threaded spring housing, and a panel mount ring to secure the regulator.

Tamper Proof - (1) in Position 15. - In this feature the control knob is removed and replaced with an acorn nut. The user can set the outlet pressure and securely tighten the nut, preventing any unwanted adjustments on the regulator.

Colored Knobs - (2, 8 and W) in Position 15. - In this feature the control knob is anodized aluminum either in black, blue or red, compared to the standard red composite knob. This allows for color coding of processes. Temperature range: -55 to 300°F (-45.6 to 149 °C).

Diaphragm Valve - (F) in Position 16. - The diaphragm valve is a shut off valve. The resolution is coarse. The extended leg allows easy access to the knob when it is attached to a regulator. The valve is 1/4" male x 1/4" female outlet. This type of valve is sold about 90% of the time.

Packed Valve - (G) in Position 16. - The packed valve is a metering valve. The resolution is very fine. The packing around the stem is Teflon. The valve is 1/4" male x 1/4" male outlet.

Relief Valve - (H, J, K, or L) in Position 16. - The relief valve main function is to relieve excess downstream pressure due to system malfunctions. This feature prevents over pressurization by automatically venting the gas or liquid. The valve is fully adjustable, and is 1/4" male x 1/4" male.

Self Relieving - (S) in Position 16. - The self relieving option features an integral mechanism allowing downstream pressure to be vented to atmosphere as the outlet pressure setting is decreased. This allows the user to easily and rapidly decrease the pressure in a closed, or low volume system without an auxiliary bleed valve. In addition, this option also functions as a sensitive relief valve. The pressure at which it relieves is automatically determined by the outlet pressure setting of the regulator.

Cleaned for Oxygen Service #S-1134 - (M) in Position 17. - This is a requirement for gaseous oxygen environments. All regulators requiring advanced cleaning shall be processed according to strict guidelines. **NOTE:** Design Pressure Rating shall not exceed 375 psig (25.8 Barg) when body material is SST and process medium is oxygen.

Cleaned per Spec. #S-1542 - (N) in Position 17. - Cleaning identical to that of #S-1134, but not labeled for application in oxygen service. NOT suitable for Oxygen Service.

DIMENSIONS

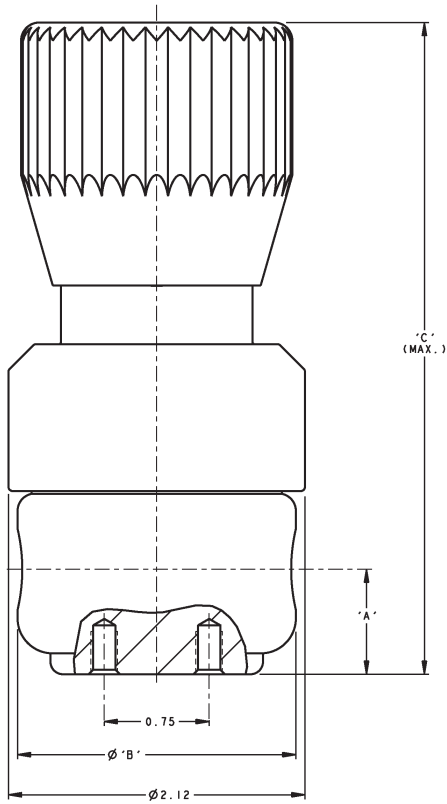

English Units In. & lbs.					
Size	A	B	C	C Dome Load	Wt
1/4" & 3/8"	.75	2.00	5.13	3.05	2.2
1/2"	.88	2.48	5.38	3.30	2.2
Metric Units mm & kg					
DN8 & DN10	19	50	130	78	1.0
DN15	22	63	137	84	1.0

Porting Configuration Guide

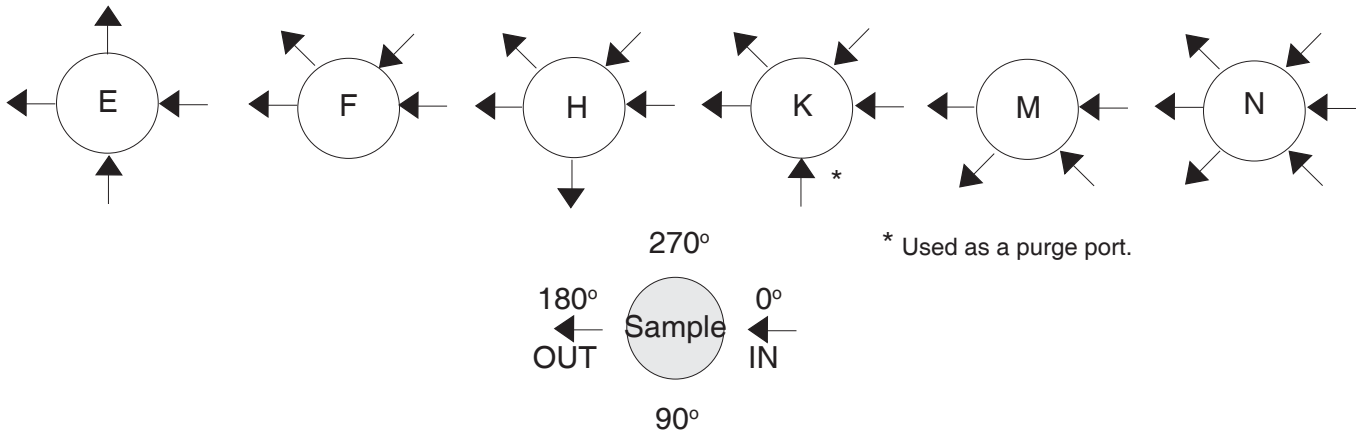

The contents of this publication are presented for informational purposes only, and while every effort has been made to ensure their accuracy, they are not to be construed as warranties or guarantees, express or implied, regarding the products or services described herein or their use or applicability. We reserve the right to modify or improve the designs or specifications of such product at any time without notice. Cashco, Inc. does not assume responsibility for the selection, use or maintenance of any product. Responsibility for proper selection, use and maintenance of any Cashco, Inc. product remains solely with the purchaser.

MODEL P2 PRODUCT CODER (COMPOSITE RED KNOB STANDARD)

02/07/20

An "X" in POS 12 followed by a 5-digit control number overrides remaining selections.

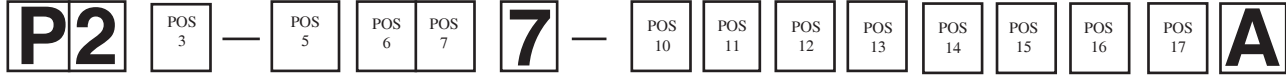

POSITION 3 - BODY SIZE / Cv		
Size	Cv	CODE
1/4" (DN8)	0.02	1
	0.06	2
	0.20	3
3/8" (DN10)	0.02	4
	0.06	5
	0.20	6
1/2" (DN15)	0.02	7
	0.06	8
	0.20	9

POSITION 5 - BODY & SPRING CHAMBER MATERIAL	
Body / Spring Chamber	CODE
316L SST / 316L SST *	S
Brass / 6061 AL	B
Brass / 316 SST	T

* Select for NACE Construction

POSITION 6 - TRIM MATERIALS		
Diaphragm , Seat Retainer, Poppet & Poppet Spring	Seat Material	CODE
302 SST w/Tefzel ring, 316L SST, 316L SST, Inconel X-750	PCTFE	1
	Polyimide	2
	TFE	3
Inconel w/TFE liner, monel R-405, Monel R-405 Inconel X-750	PCTFE	4
	Polyimide	5
	TFE	6
NACE - Inconel w/TFE liner, 316L SST, 316L SST, Inconel X-750	PCTFE	P
	TFE	R

POSITION 7 - PORTING CONFIGURATION	
Description	CODE
See Porting Guide	E
	F
	H
	K
	M
	N

POSITION 10 - END CONNECTIONS	
End Connection(s)	CODE
FNPT	1
CGA End Connection #330 *	5
CGA End Connection #346 *	2
CGA End Connection #350 *	3
CGA End Connection #540 *	A
CGA End Connection #580 *	H
CGA End Connection #590 *	L
CGA End Connection #660 *	R

Consult factory for other CGA connections.
* 1/4" Body Size only.

POSITION 11 - RANGE SPRING/OUTLET PRESSURE	
Psig (Barg)	CODE
Pneumatic Dome Loaded 0 - 125 (0 - 8.6)	0
1 - 10 (.07 - .69)	1
2 - 25 (.14 - 1.7)	2
2 - 50 (.14 - 3.4)	3
2 - 100 (.14 - 6.9)	4
3 - 250 (.21 - 17.2)	5
5 - 500 (.34 - 34.5)	6
10 - 750 (.69 - 51.7) ‡	7

‡ Only Available with SST Spr. Chamber

POSITION 12 - OUTLET GAUGE	
Psig (Barg)	CODE
0 - 15 (0 - 1.0)	A
0 - 30 (0 - 2.1)	B
0 - 60 (0 - 4.1)	C
0 - 100 (0 - 6.9)	D
0 - 160 (0 - 11.0)	E
0 - 300 (0 - 20.7)	F
0 - 600 (0 - 41.4)	G
0 - 1000 (0 - 69.0)	H
No Outlet Gauge	0
For Special Construction Contact Cashco for Special Product Code	X

POSITION 13 - INLET GAUGE	
Psig (Barg)	CODE
0 - 15 (0 - 1.0)	A
0 - 30 (0 - 2.1)	B
0 - 60 (0 - 4.1)	C
0 - 100 (0 - 6.9)	D
0 - 160 (0 - 11.0)	E
0 - 300 (0 - 20.7)	F
0 - 600 (0 - 41.4)	G
0 - 1000 (0 - 69.0)	H
0 - 2000 (0 - 137.9)	I
0 - 3000 (0 - 206.9)	J
0 - 5000 (0 - 344.9)	K
No Inlet Gauge	0

POSITION 14 - OPTIONS			
OPTIONS	CODE	OPTIONS	CODE
No Option	0	Panel Mount	C
Mounting Bracket	5		

POSITION 15 - OPTIONS			
OPTIONS	CODE	OPTIONS	CODE
No Option	0	Blue Knob	8
Tamper Proof	1	Red Knob	W
Black Knob	2		

POSITION 16 - OPTIONS			
OPTIONS	CODE	OPTIONS	CODE
No Option	0	Relief Valve: 50-150 psig *	J
Diaphragm Valve	F	Relief Valve: 150-350 psig *	K
Packed Valve	G	Relief Valve: 350-600 psig *	L
Relief Valve: 3-50 psig *	H	Self-Relieving.	S

* When selecting Relief Valve indicate SET POINT PRESSURE in Special Instructions on order. If outlet gauge is also specified, Body Port Configuration must have two outlet ports. See Porting Guide page 3.

*** For information on ATEX see
pages 8 & 9 on the IOM.**

Алматы (7273)495-231
Ангарск (3955)60-70-56
Архангельск (8182)63-90-72
Астрахань (8512)89-46-04
Барнаул (3852)73-04-60
Белгород (4722)40-23-64
Благовещенск (4162)22-76-07
Брянск (4832)59-03-52
Владивосток (423)249-28-31
Владикавказ (8672)28-90-48
Владимир (4922)49-43-18
Волгоград (844)278-03-48
Вологда (8172)26-41-59
Воронеж (473)204-51-73
Екатеринбург (343)384-55-89

Иваново (4932)77-34-06
Ижевск (3412)26-03-58
Иркутск (395)279-93-46
Казань (843)206-01-48
Калининград (4012)72-03-81
Калуга (4842)92-23-67
Кемерово (3842)65-04-62
Киров (8332)68-02-04
Коломна (4966)23-41-49
Кострома (4942)77-07-48
Краснодар (861)203-40-90
Красноярск (391)204-63-61
Курск (4712)77-13-04
Курган (3522)50-90-47
Липецк (4742)62-20-81

Магнитогорск (3519)55-03-13
Москва (495)268-04-70
Мурманск (8152)59-64-93
Набережные Челны (8552)20-53-41
Нижний Новгород (831)429-08-12
Новокузнецк (3843)20-46-81
Ноябрьск (3496)41-32-12
Новосибирск (383)227-86-73
Омск (3812)21-46-40
Орел (4862)44-53-42
Оренбург (3532)37-68-04
Пенза (8412)22-31-16
Петрозаводск (8142)55-98-37
Псков (8112)59-10-37
Пермь (342)205-81-47

Ростов-на-Дону (863)308-18-15
Рязань (4912)46-61-64
Самара (846)206-03-16
Санкт-Петербург (812)309-46-40
Саратов (845)249-38-78
Севастополь (8692)22-31-93
Саранск (8342)22-96-24
Симферополь (3652)67-13-56
Смоленск (4812)29-41-54
Сочи (862)225-72-31
Ставрополь (8652)20-65-13
Сургут (3462)77-98-35
Сыктывкар (8212)25-95-17
Тамбов (4752)50-40-97
Тверь (4822)63-31-35

Тольятти (8482)63-91-07
Томск (3822)98-41-53
Тула (4872)33-79-67
Тюмень (3452)66-21-18
Ульяновск (8422)24-23-59
Улан-Удэ (3012)59-97-51
Уфа (347)229-48-12
Хабаровск (4212)92-98-04
Чебоксары (8352)28-53-07
Челябинск (351)202-03-61
Череповец (8202)49-02-64
Чита (3022)38-34-83
Якутск (4112)23-90-97
Ярославль (4852)69-52-93

Россия +7(495)268-04-70

Казахстан +7(7172)727-132

Киргизия +996(312)96-26-47

<https://cashco.nt-rt.ru/> || coc@nt-rt.ru