



ISO Registered Company



DL-TB
09-21

MODEL DL

PRESSURE REDUCING REGULATOR



MODEL DL

OVERVIEW

The Model DL is a basic, general service, self contained regulator. Unit handles inlet pressure of up to 740 psig (51 Barg) and outlet pressures from 2-150 psig (.14-10.3 Barg) in multiple spring ranges. Model DL is the Cashco reducing regulator product utilized for the majority of industrial applications. A time-proven product with 80+ years of experience.

FEATURES

- Versatile:** Four body materials and thirty one trim material combinations to select from.
- Tight Shutoff:** Composition seats of PTFE, Buna-N (NBR), FKM, or EPDM.
- Capacity:** Handles mid-range flow rates on a line size basis.
- Pressure Drop:** Handles mid-range pressure drops while maintaining good stability.
- Flow-to-Close Plug:** Incorporates the typical reducing regulator internal design.
- Incorporated Cylinder:** Plug is guided through its travel by the cylinder, which also serves to block harmful debris from entry to the seating surfaces.



LINE SIZES AVAILABLE
1-1/2" (DN40), 2" (DN50)



END CONNECTIONS
NPT, FLANGED, BSPT,
BSPP, EXTENDED NIPPLES



COMMON APPLICATIONS
SOUR GAS, INDUSTRIAL GASES,
CHEMICALS, WATER, OIL, STEAM,
COMPRESSED AIR



DESIGN PRESSURE
INLET: UP TO 740 psig (51 Barg)
OUTLET: 2-150 psig (0.14-10.3 Barg)

Алматы (7273)495-231
Ангарск (3955)60-70-56
Архангельск (8182)63-90-72
Астрахань (8512)99-46-04
Барнаул (3852)73-04-60
Белгород (4722)40-23-64
Благовещенск (4162)22-76-07
Брянск (4832)59-03-52
Владивосток (423)249-28-31
Владикавказ (8672)28-90-48
Владимир (4922)49-43-18
Волгоград (844)278-03-48
Вологда (8172)26-41-59
Воронеж (473)204-51-73
Екатеринбург (343)384-55-89

Иваново (4932)77-34-06
Ижевск (3412)26-03-58
Иркутск (395)279-98-46
Казань (843)206-01-48
Калининград (4012)72-03-81
Калуга (4842)92-23-67
Кемерово (3842)65-04-62
Киров (8332)68-02-04
Коломна (4966)23-41-49
Кострома (4942)77-07-48
Краснодар (861)203-40-90
Красноярск (391)204-63-61
Курск (4712)77-13-04
Курган (3522)50-90-47
Липецк (4742)52-20-81

Магнитогорск (3519)55-03-13
Москва (495)268-04-70
Мурманск (8152)59-64-93
Набережные Челны (8552)20-53-41
Нижний Новгород (831)429-08-12
Новокузнецк (3843)20-46-81
Ноябрьск (3496)41-32-12
Новосибирск (383)227-86-73
Омск (3812)21-46-40
Орел (4862)44-53-42
Оренбург (3532)37-68-04
Пенза (8412)22-31-16
Петрозаводск (8142)55-98-37
Псков (8112)59-10-37
Пермь (342)205-81-47

Ростов-на-Дону (863)308-18-15
Рязань (4912)46-61-64
Самара (846)206-03-16
Санкт-Петербург (812)309-46-40
Саратов (845)249-38-78
Севастополь (8692)22-31-93
Саранск (8342)22-96-24
Симферополь (3652)67-13-56
Смоленск (4812)29-41-54
Сочи (862)225-72-31
Ставрополь (8652)20-65-13
Сургут (3462)77-98-35
Сыктывкар (8212)25-95-17
Тамбов (4752)50-40-97
Тверь (4822)63-31-35

Тольятти (8482)63-91-07
Томск (3822)98-41-53
Тула (4872)33-79-87
Тюмень (3452)66-21-18
Ульяновск (8422)24-23-59
Улан-Удэ (3012)59-97-51
Уфа (347)229-48-12
Хабаровск (4212)92-98-04
Чебоксары (8352)28-53-07
Челябинск (351)202-03-61
Череповец (8202)49-02-64
Чита (3022)38-34-83
Якутск (4112)23-90-97
Ярославль (4852)69-52-93

Россия +7(495)268-04-70

Казахстан +7(7172)727-132

Киргизия +996(312)96-26-47

STANDARD/GENERAL SPECIFICATIONS

Line Sizes:	1-1/2" (DN40) and 2" (DN50).	Ported Spring Chamber:	Spring chamber port threaded 1/4" (DN8) NPT for use with vented plug or piping to a remote location. Removable vented plug included. Not suitable for capturing flammable or lethal media.
End Connections:	<u>NPT</u> : Female Pipe Threads. <u>Flanged</u> : Mates with ASME 150, ASME 300, or PN40 flanged end connections. 14" (356 mm) face to face dimension only. <u>Option-31</u> : BSPT Tapered Thread. <u>Option-31P</u> : BSPP Parallel Thread. <u>Opt-32</u> : Extended Pipe Nipples.	Temperature:	See Tables 1, 3, 4(a), and 4(b) for temperature limitations.
Body/Spring Chamber	DI/DI, BRZ/DI, CS/DI, SST/DI, BRZ/BRZ, CS/CS, SST/CS, and SST/SST	Outlet Pressure:	<u>Standard</u> : 2-150 psig (0.14- 10.3Barg) in four range springs. See Table 2.
Material Combinations:	DI = Cast Ductile Iron ASTM A395 60-40-18 CS = Cast Carbon Steel ASTM A352 LCC BRZ = Cast Bronze ASTM B62 C83600 SST = Cast Stainless Steel ASTM A351 CF8M	Pressure Drop:	Up to 150 psid (10.3 Bard). Dependent on range spring selection. See Table 2.
Body Cap Materials	<u>Brass</u> : For use with bronze bodies. ASTM B16 C36000 <u>Stainless Steel</u> : For use with all other body materials. ASTM A479 316/316L	Trim Designs:	Metal or composition seats with brass or stainless steel materials. Metal or composition diaphragms. See Tables 3, 4(a), and 4(b).
Inlet Pressure:	Up to 740 psig (51 Barg). See Table 1 for pressure specifications.	Capacities:	Up to 10 Cv. See Table 7 for Cv vs. outlet pressure vs. body size vs. diaphragm material. Flow Tables <u>Water</u> - See Table 8. <u>Compressed Air</u> - See Table 9. <u>Steam</u> - See Table 10.
Gaskets	<u>Standard</u> : Gylon 3502 gasket for use with metal diaphragms only. PTFE cylinder gasket.	Seat Leakage:	See Table 6 for wide open capacities for use for safety relief sizing. Composition (soft) seated: Meets ANSI/FCI 70-3 Class VI. Metal Seated: Meets or exceeds ANSI/ FCI 70-3 Class IV.
Range Springs	<u>Carbon Steel</u> : For use with carbon steel and ductile iron spring chambers. <u>Stainless Steel</u> : For use with bronze and stainless steel spring chambers.	Spring Chamber Vented Plug:	1/4" (DN8) NPT polyethylene vented plug to allow for spring chamber displacement. Use stainless steel vented plug (Opt-25S) for cryogenic service.
Flange Bolting	<u>Standard</u> : 304 Stainless Steel ASTM F593 Group 1		
Painting	<u>Standard</u> : All non-corrosion resistant body, spring chamber/cover dome materials are epoxy coated per Cashco specification S-1606.		

OPTION SPECIFICATIONS

Option -3:	HANDWHEEL & LOCKING LEVER: For use when outlet pressure setting changes are frequent.	Option -45:	CRYOGENIC CONSTRUCTION: Bronze or stainless steel body/spring chamber materials only. Spring chamber includes condensate drain hole near adjusting screw. Requires stainless steel vented plug (Opt-25S). Assembled with lubricants suitable for cryogenic service. Special cleaning not included. Requires spring chamber oriented downwards in horizontal piping installations.
Option -25S:	STAINLESS STEEL VENTED PLUG: 1/4" (DN8) NPT stainless steel vented plug to allow spring chamber displacement. Required for cryogenic service.	Option -55:	OXYGEN CLEANING: Cleaning per Cashco specification S-1134 for oxygen service. Includes sealed enclosure bag and notification tag. Stainless steel or bronze body/spring chamber materials only.
Option -31:	BSPT END CONNECTIONS: British Standard Pipe Taper threads per ISO 7-1.	Option -56:	NON-OXYGEN CLEANING: Cleaning per Cashco specification S-1542. Cleaning identical to that of Opt-55, but not labeled nor suitable for oxygen service. For use with all body/spring chamber materials.
Option -31P:	BSPP END CONNECTIONS: British Standard Pipe Parallel threads per ISO 7-1. Not available on 1-1/2" (DN40) line size.	Option -87:	GAUGE PORTS: Includes two 1/8" NPT (DN6) body taps. One located on the inlet, one on the outlet for gauge connections. Plugs included.
Option -32:	PLAIN END EXTENDED NIPPLES: Schedule 80 plain end extended pipe nipples available for carbon steel or stainless steel bodies. Not available with cryogenic construction.	ATEX 2014/34/EU:	Declaration of Conformity certificate and appropriate nameplate markings available. See Model D IOM for more details.
NACE MR0175	Internal wetted portions meet NACE standard MR0175, when exterior of the regulator is not directly exposed to a sour gas environment, buried, insulated, or otherwise denied direct atmospheric exposure. Carbon steel and stainless steel body/spring chamber materials with S40, S40B, S40C, S40T, and S40V trims only.	PED 2014/68 /EU:	Declaration of Conformity certificate available up to Hazard Category II.

TECHNICAL SPECIFICATIONS

TABLE 1 MODEL D DESIGN PRESSURE VS. TEMPERATURE RATINGS RATINGS PER ASME B31.3

End Connection	Materials of Construction (Body/Spring Chamber)	Design Conditions							
		Inlet				Outlet			
		Containment Pressure		Temperature		Containment Pressure		Temperature	
		PSIG	(Barg)	°F	(°C)	PSIG	(Barg)	°F	(°C)
NPT, BSPT, BSPP, & PE NIPPLES	DI/DI	740	(51.0)	-20 to +100	(-29 to +40)	175	(12.1)	-20 to +100	(-29 to +40)
		700	(48.2)	200	(93)	175	(12.1)	200	(93)
		660	(45.5)	300	(149)	175	(12.1)	300	(149)
		625	(43.1)	400	(204)	175	(12.1)	400	(204)
		585	(40.3)	500	(260)	175	(12.1)	500	(260)
		550	(37.9)	600	(316)	175	(12.1)	600	(316)
	BRZ/DI	740	(51.0)	-20 to +100	(-29 to +40)	175	(12.1)	-20 to +100	(-29 to +40)
		730	(50.3)	200	(93)	175	(12.1)	200	(93)
		640	(44.1)	300	(149)	175	(12.1)	300	(149)
		585	(40.3)	400	(200)	175	(12.1)	400	(200)
	BRZ/BRZ	740	(51.0)	-325 to +150	(-198 to +65)	175	(12.1)	-325 to +150	(-198 to +65)
		730	(50.3)	200	(93)	175	(12.1)	200	(93)
		680	(46.8)	250	(121)	175	(12.1)	250	(121)
		640	(44.1)	300	(149)	175	(12.1)	300	(149)
		610	(42.0)	350	(177)	175	(12.1)	350	(177)
		585	(40.3)	400	(200)	175	(12.1)	400	(200)
	CS/DI, CS/CS, SST/CS, & SST/DI	740	(51.0)	-20 to +200	(-29 to +93)	175	(12.1)	-20 to +200	(-29 to +93)
		740	(51.0)	300	(149)	175	(12.1)	300	(149)
		740	(51.0)	400	(204)	175	(12.1)	400	(204)
		740	(51.0)	500	(260)	175	(12.1)	500	(260)
		740	(51.0)	600	(316)	175	(12.1)	600	(316)
	SST/SST	740	(51.0)	-325 to +200	(-198 to +93)	175	(12.1)	-325 to +200	(-198 to +93)
		740	(51.0)	300	(149)	175	(12.1)	300	(149)
		740	(51.0)	400	(204)	175	(12.1)	400	(204)
		740	(51.0)	500	(260)	175	(12.1)	500	(260)
		740	(51.0)	600	(316)	175	(12.1)	600	(316)
	CS/BRZ	740	(51.0)	-20 to +150	(-29 to +65)	175	(12.1)	-20 to +150	(-29 to +65)
		740	(51.0)	200	(93)	175	(12.1)	200	(93)
		740	(51.0)	250	(121)	175	(12.1)	250	(121)
		740	(51.0)	300	(149)	175	(12.1)	300	(149)
		740	(51.0)	350	(177)	175	(12.1)	350	(177)
		740	(51.0)	400	(200)	175	(12.1)	400	(200)
	DI/BRZ	740	(51.0)	-20 to +100	(-29 to +40)	175	(12.1)	-20 to +100	(-29 to +40)
		700	(48.2)	200	(93)	175	(12.1)	200	(93)
		660	(45.5)	300	(149)	175	(12.1)	300	(149)
		625	(43.1)	400	(200)	175	(12.1)	400	(200)
SST/BRZ	740	(51.0)	-325 to +150	(-198 to +65)	175	(12.1)	-325 to +150	(-198 to +65)	
	740	(51.0)	200	(93)	175	(12.1)	200	(93)	
	740	(51.0)	250	(121)	175	(12.1)	250	(121)	
	740	(51.0)	300	(149)	175	(12.1)	300	(149)	
	740	(51.0)	350	(177)	175	(12.1)	350	(177)	
	740	(51.0)	400	(200)	175	(12.1)	400	(200)	

NOTES:

- 1.) CS can be either ASTM A216 WCB or ASTM A352 LCC. With properly selected materials, valves using ASTM A352 LCC have a minimum temperature rating of -50°F (-46°C).
- 2.) Pressure rating shall not exceed 375 psig (26 Barg) when body is stainless steel and process medium is oxygen. Temperature rating shall not exceed 400°F (200°C) for all above materials when the process medium is oxygen. (CGA G-4.4)

TABLE 1 (Continued)
MODEL D DESIGN PRESSURE VS. TEMPERATURE RATINGS
RATINGS PER ASME B31.3

End Connection	Materials of Construction (Body/Spring Chamber)	Design Conditions								
		Inlet				Outlet				
		Containment Pressure		Temperature		Containment Pressure		Temperature		
		PSIG	(Barg)	°F	(°C)	PSIG	(Barg)	°F	(°C)	
Class 150 Flanged	CS/CS	285	(19.6)	-50 to +100	(-45 to +38)	175	(12.1)	-20 to +100	(-29 to +38)	
		260	(17.9)	200	(93)	175	(12.1)	200	(93)	
		230	(15.8)	300	(149)	175	(12.1)	300	(149)	
		200	(13.7)	400	(204)	175	(12.1)	400	(204)	
		170	(11.7)	500	(260)	170	(11.7)	500	(260)	
		140	(9.6)	600	(316)	140	(9.6)	600	(316)	
	SST/SST	275	(19.0)	-325 to +100	(-198 to +38)	175	(12.1)	-325 to +100	(-198 to +38)	
		235	(16.2)	200	(93)	175	(12.1)	200	(93)	
		215	(14.8)	300	(149)	175	(12.1)	300	(149)	
		195	(13.4)	400	(204)	175	(12.1)	400	(204)	
		170	(11.7)	500	(260)	170	(11.7)	500	(260)	
		140	(9.6)	600	(316)	140	(9.6)	600	(316)	
	CS/BRZ	285	(19.6)	-20 to +100	(-29 to +38)	175	(12.1)	-20 to +100	(-29 to +38)	
		260	(17.9)	200	(93)	175	(12.1)	200	(93)	
		230	(15.8)	300	(149)	175	(12.1)	300	(149)	
		200	(13.7)	400	(204)	175	(12.1)	400	(204)	
	SST/BRZ	275	(19.0)	-325 to +100	(-198 to +38)	175	(12.1)	-325 to +100	(-198 to +38)	
		235	(16.2)	200	(93)	175	(12.1)	200	(93)	
		215	(14.8)	300	(149)	175	(12.1)	300	(149)	
		195	(13.4)	400	(204)	175	(12.1)	400	(204)	
	Class 300 Flanged	CS/CS	740	(51.0)	-50 to +100	(-45 to +38)	175	(12.1)	-20 to +100	(-29 to +38)
			680	(46.8)	200	(93)	175	(12.1)	200	(93)
			655	(45.1)	300	(149)	175	(12.1)	300	(149)
			635	(43.7)	400	(204)	175	(12.1)	400	(204)
605			(41.7)	500	(260)	175	(12.1)	500	(260)	
570			(39.3)	600	(316)	175	(12.1)	600	(316)	
SST/SST		720	(49.6)	-325 to +100	(-198 to +38)	175	(12.1)	-325 to +100	(-198 to +38)	
		620	(42.7)	200	(93)	175	(12.1)	200	(93)	
		560	(38.6)	300	(149)	175	(12.1)	300	(149)	
		515	(35.5)	400	(204)	175	(12.1)	400	(204)	
		480	(33.1)	500	(260)	175	(12.1)	500	(260)	
		450	(31.0)	600	(316)	175	(12.1)	600	(316)	
CS/BRZ		740	(51.0)	-20 to +100	(-29 to +38)	175	(12.1)	-20 to +100	(-29 to +38)	
		680	(46.8)	200	(93)	175	(12.1)	200	(93)	
		655	(45.1)	300	(149)	175	(12.1)	300	(149)	
		635	(43.7)	400	(204)	175	(12.1)	400	(204)	
SST/BRZ		720	(49.6)	-325 to +100	(-198 to +38)	175	(12.1)	-325 to +100	(-198 to +38)	
		620	(42.7)	200	(93)	175	(12.1)	200	(93)	
		560	(38.6)	300	(149)	175	(12.1)	300	(149)	
		515	(35.5)	400	(204)	175	(12.1)	400	(204)	

NOTES:

1.) CS can be either ASTM A216 WCB or ASTM A352 LCC. With properly selected materials, valves using ASTM A352 LCC have a minimum temperature rating of -50°F (-46°C).

2.) Pressure rating shall not exceed 375 psig (26 Barg) when body is stainless steel and process medium is oxygen. Temperature rating shall not exceed 400°F (200°C) for all above materials when the process medium is oxygen. (CGA G-4.4)

TABLE 1 (Continued)
MODEL D DESIGN PRESSURE VS. TEMPERATURE RATINGS
RATINGS PER ASME B31.3

End Connection	Materials of Construction (Body/Spring Chamber)	Design Conditions							
		Inlet				Outlet			
		Containment Pressure		Temperature		Containment Pressure		Temperature	
		PSIG	(Barg)	°F	(°C)	PSIG	(Barg)	°F	(°C)
PN40 Flanged	CS/CS	580	(40.0)	-50 to +392	(-45 to +200)	175	(12.1)	-20 to +392	(-29 to +200)
		565	(38.2)	500	(260)	175	(12.1)	500	(260)
		490	(34.1)	600	(315)	175	(12.1)	600	(315)
	SST/SST	580	(40.0)	-325 to +300	(-198 to +149)	175	(12.1)	-325 to +300	(-198 to +149)
		535	(37.2)	400	(204)	175	(12.1)	400	(204)
		505	(35.0)	500	(260)	175	(12.1)	500	(260)
		480	(33.2)	600	(315)	175	(12.1)	600	(315)
	CS/BRZ	580	(40.0)	-20 to +250	(-29 to +121)	175	(12.1)	-20 to +250	(-29 to +121)
		580	(40.0)	302	(150)	175	(12.1)	300	(149)
		580	(40.0)	392	(200)	175	(12.1)	392	(200)
		575	(39.9)	400	(204)	175	(12.1)	400	(204)
	SST/BRZ	580	(40.0)	-325 to +250	(-198 to +121)	175	(12.1)	-325 to +250	(-198 to +121)
		580	(40.0)	300	(149)	175	(12.1)	300	(149)
		535	(37.2)	400	(204)	175	(12.1)	400	(204)

NOTES:

- 1.) CS can be either ASTM A216 WCB or ASTM A352 LCC. With properly selected materials, valves using ASTM A352 LCC have a minimum temperature rating of -50°F (-46°C).
- 2.) Pressure rating shall not exceed 375 psig (26 Barg) when body is stainless steel and process medium is oxygen. Temperature rating shall not exceed 400°F (200°C) for all above materials when the process medium is oxygen. (CGA G-4.4)

**TABLE 2
RANGE SPRINGS WITH RECOMMENDED PRESSURE DROPS**

Range Spring		Recommended Max. Pressure Drop					
		Liquid Service (Non-Cavitating)		Gaseous Service		Steam Service ¹	
psig	(Barg)	psid	(Bard)	psid	(Bard)	psid	(Bard)
2-15	(0.14-1.03)	100	(6.9)	125	(8.6)	100	(6.9)
10-40	(0.69-2.8)	125	(8.6)	150	(10.3)	125	(8.6)
30-80	(2.1-5.5)	150	(10.3)	150	(10.3)	150	(10.3)
70-150	(4.8-10.3)	150	(10.3)	150	(10.3)	150	(10.3)

NOTES: 1) B0 and B1 trim: 100 psid (3.4 Bard) max when used on steam service.

**TABLE 3
BRASS TRIM MATERIAL COMBINATIONS**

PART	BRASS TRIM #						
	METAL SEAT		COMPOSITION SEAT				
	B0 ¹	B1 ¹	B2 (Air/H2O)	B4	B5 (Oxygen)	BB (Fuel-Oils)	BK
Diaphragm	Phos Brz	302 SST	BC	FKM	Phos Brz	NBR	FKM
Diaphragm Gasket	Gylon 3502	Gylon 3502	None	None	Gylon 3502	None	None
Cylinder	Brass	Brass	Brass	Brass	Brass	Brass	Brass
Cylinder Gasket	PTFE	PTFE	PTFE	PTFE	PTFE	PTFE	PTFE
Piston	Brass	Brass	Brass	Brass	Brass	Brass	Brass
Seat Disc	None (Metal)	None (Metal)	NBR	PTFE	PTFE	NBR	FKM
Piston Spring	302 SST	302 SST	Phos. Brz	302 SST	Phos Brz	Phos Brz	Phos Brz
Pusher Plate	Brass	Brass	Brass	Brass	Brass	Brass	Brass
Temperature Range	-325 to +200°F -198 to +93°C	-325 to +400°F -198 to +204°C	-20 to +200°F -29 to 93°C	0 to +400°F -18 to +204°C	-325 to +200°F -198 to +93°C	-20 to 200°F -29 to +93°C	0 to +200°F -18 to +93°C

NOTES:
1) B0 and B1 trim: 100 psid (6.9 Bard) max when used on steam service.
2) Metal seated trim is not recommended on any service where the flow will be dead ended down stream of the pressure reducing regulator.

= Most common use - See Table 5

**TABLE 4(a)
STAINLESS STEEL TRIM MATERIAL COMBINATION – METAL SEAT**

PART	STAINLESS STEEL TRIM#					
	S0	S1	S2 (Steam)	S2N	S40 (NACE)	S40B (NACE)
Diaphragm	TFE Coated 302 SST	302 SST	302 SST	BC	BC	Low Temp BC
Diaphragm Gasket	Gylon 3502	Gylon 3502	Gylon 3502	None	None	None
Cylinder	316 SST	316 SST	416 SST	416 SST	316 SST	316 SST
Cylinder Gasket	PTFE	PTFE	PTFE	PTFE	PTFE	PTFE
Piston	316 SST	316 SST	416 SST	416 SST	316 SST	316 SST
Piston Spring	302 SST	302 SST	302 SST	302 SST	Inconel X-750	Inconel X-750
Pusher Plate	316 SST	316 SST	316 SST	316 SST	316 SST	316 SST
Temperature Range	-325 to +400°F -198 to +204°C		-20 to +400°F -29 to +93°C	-20 to +200°F -29 to +93°C		-65 to +250°F -54 to +121°C

NOTES:
1) Metal seated trim is not recommended on any service where the flow will be dead ended down stream of the pressure reducing regulator.

= Most common use - See Table 5

TABLE 4(b)
MONEL & STAINLESS STEEL TRIM MATERIAL COMBINATION – COMPOSITION (SOFT) SEAT

PART	STAINLESS STEEL TRIM#												
	S3	S4	S4N (Air/H ₂ O)	S6	S9	S36	S40T (NACE)	S40V (NACE)	S40C (NACE)	SB	SK		
Diaphragm	BC	BC	BC	EPDM	TFE Coated 302 SST	302 SST	FKM	FKM	Low Temp BC	NBR	FKM		
Diaphragm Gasket	None	None	None	None	Gylon 3502	Gylon 3502	None	None	None	None	None		
Cylinder	316 SST	416 SST	416 SST	316 SST	316 SST	316 SST	316 SST	316 SST	316 SST	416 SST	316 SST		
Cylinder Gasket	PTFE	PTFE	PTFE	PTFE	PTFE	PTFE	PTFE	PTFE	PTFE	PTFE	PTFE		
Piston	316 SST	416 SST	416 SST	316 SST	316 SST	316 SST	316 SST	316 SST	316 SST	416 SST	316 SST		
Seat Disc	PTFE	PTFE	NBR	EPR	PTFE	PTFE	PTFE	FKM	PTFE	NBR	FKM		
Piston Spring	302 SST	302 SST	302 SST	302 SST	302 SST	302 SST	Inconel X-750	Inconel X-750	Inconel X-750	302 SST	302 SST		
Pusher Plate	316 SST	316 SST	316 SST	316 SST	316 SST	316 SST	316 SST	316 SST	316 SST	316 SST	316 SST		
Temperature Range	-20 to +200°F -29 to +93°C			-60 to +300°F -51 to +149°C		-325 to +400°F -198 to +204°C		-0 to +400°F -18 to +204°C		-65 to +250°F -54 to +121°C		-20 to +200F -29 to +93C	-20 to +300°F -29 to +149°C

ABBREVIATIONS

NBR = Buna-N BC = Neoprene EPDM = Ethylene Propylene Diene EPR = Ethylene Propylene PTFE = Polytetrafluoroethylene
FK = Fluorosilicone FKM = Fluorocarbon Elastomer Phos Brz = Phosphor Bronze

TABLE 5
APPLICATIONS

FLUID	RECOMMENDED CONSTRUCTION	TRIM DESIGNATION#
Air or Inert Gases	Composition Seat and Diaphragm Metal Seat and Composition Diaphragm Metal Seat and Diaphragm	BB, BK, B2 , B4, SB, SK, S4N S2N B0, B1
Oxygen	Metal Seat and Diaphragm Composition Seat and Metal Diaphragm Composition Seat and Diaphragm	S1 B5 , S36 BK, B4 , S40T , SK
Chemicals	Metal Seat and Diaphragm Metal Seat and Composition Diaphragm Composition Seat and Diaphragm TFE Seat and Metal Diaphragm	S1, S2, S0 S40 S3, S4, S4N, SB, SK, S40T S6, S9
Sour Gas	Metal Seat and Composition Diaphragm Composition Seat and Diaphragm	S40, S40B S40T, S40V, S40C
Fuel Oil [¶]	Composition Seat and Diaphragm	BB , B4, SB , S3, S4, S4N
Hydrocarbon Gas or Liquids [¶]	Composition Seat and Diaphragm	BB, B4, SK, S3, S4, S4N
Saturated Steam, Low Pressures up to 50 psig (3.4 Barg)	Metal Seat and Diaphragm	S2 , S1, S6, B0
Saturated Steam, Pressures up to 100 psig (6.8 Barg) 50 psid (3.4 Barg)	Metal Seat and Diaphragm	S2 , S1, B0
Steam Pressures above 100 psig (6.9 Barg) Saturated or Superheated	Metal Seat and Diaphragm	S2 , S1
Water and Condensate Low Temperature 32-180°F (0-83°C)	Composition Seat and Diaphragm Metal Seat and Composition Diaphragm Metal Seat and Diaphragm	BB, B2 , SB, S3 , S4, S4N S2N S1, S2
Water and Condensate High Temperature 180-300°F (83-149°C)	Metal Seat and Diaphragm	S1 , S2

NOTES:

- 1) Trim designation numbers in bold are used most common and have been successfully applied in similar applications. Consult factory for the suitability of certain trims for specific services; however, the end user has final responsibility for materials selected.
- 2) Metal seated trim is not recommended on any service where the flow will be dead ended down stream of the pressure reducing regulator.

TABLE 6
MAXIMUM CAPACITY WITH PLUG WIDE OPEN
(Use for Relief Valve Sizing)

Line Size	Cv	kv
1-1/2" (DN40)	7.0	6.1
2" (DN50)	10.0	8.7

**TABLE 7
CAPACITY (Cv)
AT FLOWING PRESSURE (F_L = 0.95)**

METAL DIAPHRAGM						
Outlet Pressure psig	1-1/2" (DN40) Body			2" (DN50) Body		
	% Droop			% Droop		
	10%	20%	30%	10%	20%	30%
5	0.54	1.22	1.94	0.60	1.46	2.55
10	0.69	1.60	2.70	0.85	2.05	3.70
15	0.84	1.98	3.41	1.05	2.64	4.80
25	0.67	1.53	2.60	0.77	1.91	3.54
35	0.80	1.86	3.20	0.97	2.43	4.36
50	1.14	2.60	4.31	1.50	3.79	7.01
75	1.50	3.41	5.52	2.00	5.17	9.07
100	1.14	2.66	4.46	1.50	3.89	7.28
150	1.56	3.65	5.92	2.15	5.58	9.59

COMPOSITION DIAPHRAGM						
Outlet Pressure psig	1-1/2" (DN40) Body			2" (DN50) Body		
	% Droop			% Droop		
	10%	20%	30%	10%	20%	30%
5	0.90	2.04	3.23	1.00	2.44	4.26
10	1.16	2.67	4.51	1.42	3.41	6.16
15	1.34	3.30	5.68	1.75	4.40	7.99
25	1.12	2.55	4.34	1.28	3.18	5.90
35	1.34	3.10	5.34	1.62	4.05	7.26
50	1.89	4.34	7.00	2.49	6.32	10.00
75	2.49	5.68	7.00	3.33	8.61	10.00
100	1.89	4.43	7.00	2.49	6.48	10.00
150	2.61	6.09	7.00	3.59	9.30	10.00

METRIC CONVERSION FACTORS: psi / 14.5 = Bar; Cv / 1.16 = kv

**TABLE 8
WATER CAPACITIES - (GPM)
S.G. =1.0 T = 60° F_L = 0.95**

COMPOSITION DIAPHRAGM ONLY							
Outlet Pressure P2, psig	Inlet Pressure P1, psig	1-1/2" (DN40) Body			2" (DN50) Body		
		DROOP			DROOP		
		10%	20%	30%	10%	20%	30%
5	25	4	9	14	5	11	19
	50	6	14	22	7	16	29
	75	8	17	27	8	20	36
	100	9	20	32	10	24	42
	125	HI DP	HI DP	HI DP	HI DP	HI DP	HI DP
10	25	5	10	18	6	13	24
	50	7	17	29	9	22	39
	75	9	22	36	11	28	50
	100	11	25	43	14	32	58
	125	HI DP	HI DP	HI DP	HI DP	HI DP	HI DP
15	25	4	10	18	6	14	25
	50	8	20	34	10	26	47
	75	10	26	44	14	34	62
	100	12	30	52	16	41	74
	125	14	35	60	18	46	84
150	HI DP	HI DP	HI DP	HI DP	HI DP	HI DP	
25	50	6	13	22	6	16	30
	75	8	18	31	9	23	42
	100	10	22	38	11	28	51
	125	11	26	43	13	32	59
	150	13	29	49	14	36	66
175	HI DP	HI DP	HI DP	HI DP	HI DP	HI DP	
35	50	5	12	21	6	16	28
	75	9	20	34	10	26	46
	100	11	25	43	13	33	59
	125	13	29	51	15	38	69
	150	14	33	57	17	43	78
175	HI DP	HI DP	HI DP	HI DP	HI DP	HI DP	
50	75	10	22	35	13	32	50
	100	13	31	50	18	45	71
	125	16	38	61	22	55	87
	150	19	43	70	25	63	100
	175	21	49	78	28	71	112
200	23	53	86	31	77	123	
75	100	13	28	35	17	43	50
	125	18	40	50	24	61	71
	150	22	49	61	29	75	87
	175	25	57	70	33	86	100
	200	28	64	78	37	96	112
100	125	10	22	35	13	32	50
	150	13	31	50	18	46	71
	175	16	38	61	22	56	87
	200	19	44	70	25	65	100
135	150	9	22	27	13	33	39
	175	15	35	44	21	53	63
	200	19	45	56	26	68	81
150	175	13	31	35	18	47	50
	200	19	43	50	25	66	71

NOTE: Where "HI DP" is indicated, the actual pressure drop has exceeded the recommended limits of Table 2.

METRIC CONVERSION FACTORS: psi / 14.5 = Bar; GPM X 3.785 = LPM

TABLE 9
AIR CAPACITY - SCFH
S.G = 1.0 T = 60°F F_L = 0.95

COMPOSITION DIAPHRAGM ONLY							
Outlet Pressure P ₂ , psig	Inlet Pressure P ₁ , psig	1-1/2" (DN40) Body Size			2" (DN50) Body Size		
		DROOP			DROOP		
		10%	20%	30%	10%	20%	30%
2	25	500	1000	1600	500	1200	2100
	50	700	1700	2700	800	2000	3500
	75	1000	2300	3700	1100	2800	4900
	100	1300	3000	4700	1500	3600	6200
	125	1600	3600	5700	1800	4400	7600
	150	HI DP	HI DP	HI DP	HI DP	HI DP	HI DP
5	25	1100	2600	4100	1300	3100	5400
	50	1900	4200	6700	2100	5000	8800
	75	2600	5800	9200	2900	7000	12200
	100	3300	7500	11800	3700	8900	15600
	125	4000	9100	14400	4500	10900	19000
	150	HI DP	HI DP	HI DP	HI DP	HI DP	HI DP
10	25	1500	3400	5700	1800	4300	7800
	50	2400	5500	9300	2900	7000	12700
	75	3300	7600	12900	4100	9700	17600
	100	4200	9800	16500	5200	12500	22500
	125	5200	11900	20100	6300	15200	27400
	150	HI DP	HI DP	HI DP	HI DP	HI DP	HI DP
15	25	1600	3900	6700	2100	5200	9500
	50	2800	6800	11700	3600	9100	16500
	75	3800	9400	16200	5000	12600	22800
	100	4900	12100	20700	6400	16100	29200
	125	6000	14700	25300	7800	19600	35600
	150	7000	17300	29800	9200	23100	41900
25	75	HI DP	HI DP	HI DP	HI DP	HI DP	HI DP
	50	2300	5100	8800	2600	6400	11900
	75	3200	7300	12400	3700	9100	16800
	100	4100	9300	15800	4700	11600	21500
	125	5000	11300	19300	5700	14200	26300
	150	5900	13400	22800	6700	16700	31000
35	175	6800	15400	26300	7700	19200	35700
	200	HI DP	HI DP	HI DP	HI DP	HI DP	HI DP
	50	2400	5500	9500	2900	7200	13000
	75	3800	8800	15100	4600	11400	20500
	100	4900	11300	19500	5900	14800	26500
	125	6000	13800	23800	7200	18000	32300
50	150	7000	16300	28000	8500	21300	38100
	175	8100	18800	32300	9800	24500	43900
	200	HI DP	HI DP	HI DP	HI DP	HI DP	HI DP
	75	4800	11100	17900	6400	16100	25500
	100	6800	15500	25100	8900	22600	35800
	125	8400	19300	31100	11100	28100	44400
75	150	9900	22800	36700	13100	33200	52500
	175	11400	26300	42300	15100	38200	60500
	200	12900	29700	47900	17100	43300	68500
	250	HI DP	HI DP	HI DP	HI DP	HI DP	HI DP
	100	7400	16900	20800	9900	25600	29800
	125	10400	23700	29200	13900	36000	41800
100	150	12800	29200	36000	17100	44300	51500
	175	15000	34200	42200	20100	51900	60200
	200	17100	38900	47900	22800	59000	68500
	250	HI DP	HI DP	HI DP	HI DP	HI DP	HI DP
	125	6300	14800	23400	8300	21700	33400
	150	8900	20800	32900	11700	30400	47000
135	175	10900	25600	40400	14400	37400	57700
	200	12700	29800	47000	16700	43500	67200
	250	15900	37400	59100	21000	54700	84400
	300	HI DP	HI DP	HI DP	HI DP	HI DP	HI DP
	150	5600	13100	20700	7300	19100	29500
	175	9000	21200	33400	11900	31000	47800
150	200	11500	26900	42600	15100	39400	60800
	250	15400	36200	57200	20300	52900	81700
	300	HI DP	HI DP	HI DP	HI DP	HI DP	HI DP
	175	10400	24200	27800	14200	36900	39700
200	14600	34000	39100	20100	51900	55900	
250	20700	48300	55500	28500	73800	79300	
300	25700	60000	69000	35400	91700	98500	

NOTE: Where "HI DP" is indicated, the actual pressure drop has exceeded the recommended limits of Table 2.

METRIC CONVERSION FACTORS: psi / 14.5 = Bar; SCFH / 35.31 = Sm³/Hr; SCFH / 37.32 = Nm³/Hr

TABLE 10
STEAM - LBS/HR
S.G. = Actual T = Saturated F_L = 0.95

METAL DIAPHRAGM ONLY								
Outlet Pressure P2, psig	Inlet Pressure P1, psig	1-1/2" (DN40) Body Size			2" (DN50) Body Size			
		DROOP			DROOP			
		10%	20%	30%	10%	20%	30%	
2	25	14	31	42	15	34	66	
	50	23	51	69	25	57	110	
	75	32	71	96	35	79	153	
	100	40	90	122	44	100	194	
	125	49	109	148	53	121	235	
	150	57	128	173	63	142	276	
	175	HI DP	HI DP	HI DP	HI DP	HI DP	HI DP	
5	25	36	81	129	40	97	170	
	50	60	135	214	66	161	282	
	75	85	192	305	94	230	401	
	100	108	244	388	120	292	510	
	125	131	296	470	145	354	618	
	150	154	347	551	171	415	725	
	175	HI DP	HI DP	HI DP	HI DP	HI DP	HI DP	
10	25	43	100	168	53	127	230	
	50	76	176	296	93	225	406	
	75	106	246	415	131	315	569	
	100	138	320	540	170	410	740	
	125	167	388	654	206	497	897	
	150	196	455	768	242	583	1052	
	175	HI DP	HI DP	HI DP	HI DP	HI DP	HI DP	
15	25	46	108	186	57	144	261	
	50	91	214	368	113	285	518	
	75	127	300	516	159	400	727	
	100	166	392	674	208	522	949	
	125	204	480	826	254	640	1163	
	150	239	563	969	299	750	1364	
	175	HI DP	HI DP	HI DP	HI DP	HI DP	HI DP	
25	50	67	153	261	77	191	355	
	75	100	228	387	115	284	527	
	100	129	294	500	148	367	681	
	125	158	360	612	181	450	834	
	150	190	435	739	219	543	1006	
	175	219	500	849	252	624	1156	
	200	HI DP	HI DP	HI DP	HI DP	HI DP	HI DP	
35	50	68	157	271	82	205	369	
	75	114	265	457	138	347	622	
	100	152	353	607	184	461	827	
	125	186	433	745	226	566	1015	
	150	219	510	877	266	666	1195	
	175	258	599	1031	313	783	1405	
	200	HI DP	HI DP	HI DP	HI DP	HI DP	HI DP	
50	75	142	323	535	186	470	870	
	100	206	469	778	271	684	1265	
	125	260	593	983	342	865	1599	
	150	310	707	1172	408	1031	1906	
	175	358	817	1354	471	1191	2203	
	200	405	924	1532	533	1348	2492	
	250	HI DP	HI DP	HI DP	HI DP	HI DP	HI DP	
75	100	216	492	796	288	746	1308	
	125	311	707	1145	415	1072	1881	
	150	389	884	1431	518	1340	2351	
	175	460	1045	1692	613	1585	2780	
	200	527	1198	1939	703	1816	3186	
	250	HI DP	HI DP	HI DP	HI DP	HI DP	HI DP	
	100	125	184	430	721	242	629	1176
150		263	614	1030	347	899	1682	
175		328	765	1282	431	1118	2093	
200		385	899	1508	507	1315	2461	
250		490	1144	1918	645	1673	3130	
300		HI DP	HI DP	HI DP	HI DP	HI DP	HI DP	
135		150	198	474	799	269	693	1216
	175	326	779	1281	442	1139	1999	
	200	419	1003	1650	569	1467	2576	
	250	572	1369	2252	776	2002	3514	
	300	HI DP	HI DP	HI DP	HI DP	HI DP	HI DP	
	150	175	299	699	1133	412	1068	1836
		200	426	996	1615	587	1522	2616
250		615	1438	2332	847	2198	3778	
300		773	1808	2932	1064	2763	4749	

NOTE: Where "HI DP" is indicated, the actual pressure drop has exceeded the recommended limits of Table 2.

DIMENSIONS & WEIGHTS

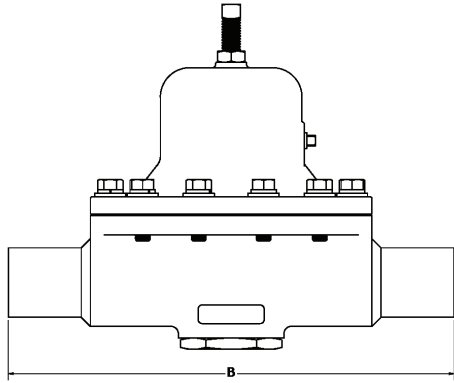

**OPTION - 32
EXTENDED NIPPLES**

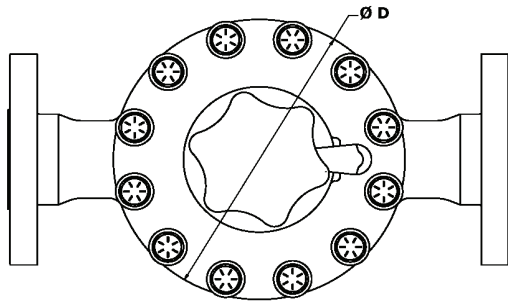
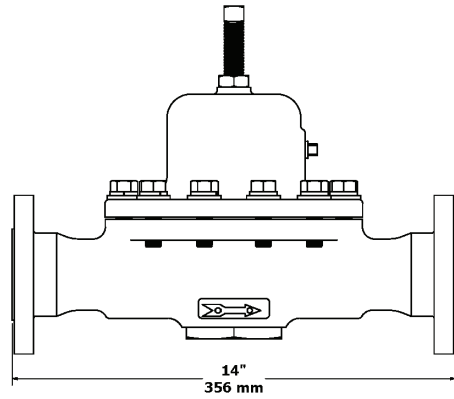

**OPTION - 3
HANDWHEEL & LOCKING LEVER
(TOP VIEW)**

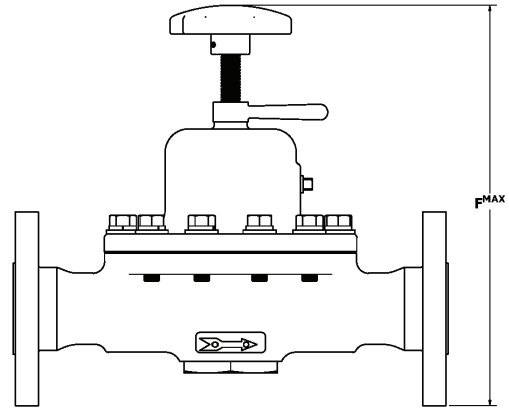

**OPTION - 3
HANDWHEEL & LOCKING LEVER**

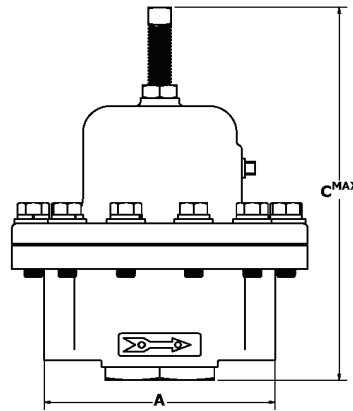

SIZE INCH	DIMENSIONS - ENGLISH (in.)					Shipping Weight (lbs)	
	A	B	C ^{MAX}	D	F ^{MAX}	NON-FLANGED	FLANGED
1-1/2	6 3/8	N/A	10 1/2	8 1/2	12 5/8	29	48
2	7 3/16	15 1/4	11 13/16	9 5/8	14 3/8	48	67
SIZE DN	DIMENSIONS - METRIC (mm)					Shipping Weight (kgs)	
	A	B	C ^{MAX}	D	F ^{MAX}	NON-FLANGED	FLANGED
40	161	N/A	266	207	321	13	22
50	182	387	300	245	266	22	31

MODEL DL - Cryogenic Service (Option -45) 09/02/21



POSITION 3 - SIZE		
Size		CODE
in.	(DN)	
1-1/2"	(40)	8
2"	(50)	9

POSITION 5 - BODY & SPRING CHAMBER MATERIALS	
Body/Sp. Ch.	CODE
BRZ/BRZ	3
SST/SST	A

POSITION 6 & 7 - TRIM DESIGNATION NUMBERS			
Brass Trim		Stainless Steel Trim	
Desig.	CODE	Desig.	CODE
B0	B0	S0	S0
B1	B1	S1	S1
B5	B5	S9	S9
		S36	36

POSITION 10 - END CONNECTIONS	
Description	CODE
NPT - Threaded	1
ASME 150 Flanges (14" Face to Face Dimension) *	V
ASME 300 Flanges (14" Face to Face Dimension) *	W
PN40 Flanges (356 mm Face to Face Dimension) *	A
Opt. -31P: BSPT Taper Threaded	B
Opt. -31P: BSPP Parallel Threaded	P

* SST Body Only

POSITION 11 - RANGE SPRING		
SST Range Spring		CODE
psig	(Barg)	
2-15	(.14-1.0)	A
10-40	(.69-2.8)	B
30-80	(2.1-5.5)	C
70-150	(4.8-10.3)	D

POSITION 15 - BODY OPTIONS		
Description	OPTION	CODE
No Option	—	0
Gauge Ports Included	-87	V

POSITION 16 - CERTIFICATE OPTIONS		
Description	OPTION	CODE
No Option	—	0
Oxygen Cleaning Per Cashco Specification S-1134.	-55	M
Non-oxygen Cleaning Per Cashco Specification S-1542	-56	N

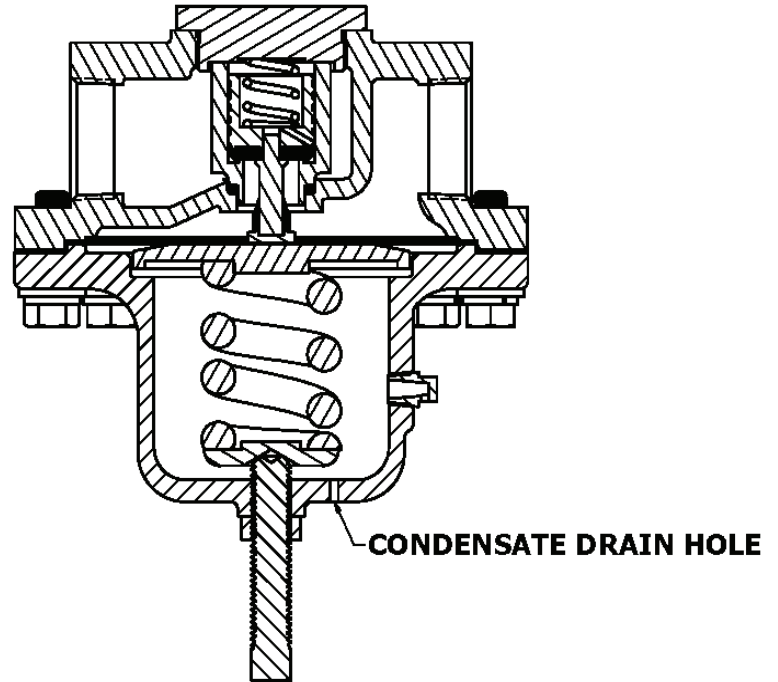

*** For information on ATEX see pages 8 & 9 on the IOM.**

CRYOGENIC SERVICE

The contents of this publication are presented for informational purposes only, and while every effort has been made to ensure their accuracy, they are not to be construed as warranties or guarantees, express or implied, regarding the products or services described herein or their use or applicability. We reserve the right to modify or improve the designs or specifications of such product at any time without notice. Cashco, Inc. does not assume responsibility for the selection, use or maintenance of any product. Responsibility for proper selection, use and maintenance of any Cashco, Inc. product remains solely with the purchaser.

MODEL DL - General Service 09/02/21

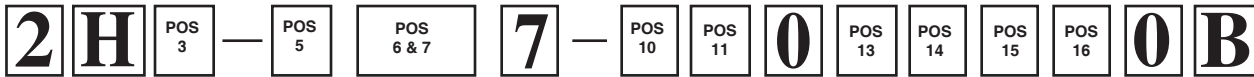

POSITION 3 - SIZE		
Size		CODE
in.	(DN)	
1-1/2"	(40)	8
2"	(50)	9

POSITION 5 - BODY & SPRING CHAMBER MATERIALS	
Body/Sp. Ch.	CODE
DI/DI	1
BRZ/DI	2
BRZ/BRZ	3
CS/DI	4
CS/CS	5
SST/DI	7
SST/CS	9
SST/SST	A

POSITION 6 & 7 - TRIM DESIGNATION NUMBERS			
Brass Trim		Stainless Steel Trim	
Desig.	CODE	Desig.	CODE
B0	B0	S0	S0
B1	B1	S1	S1
B2	B2	S2	S2
B4	B4	S2N	SN
B5	B5	S3	S3
BB	BB	S4	S4
BK	BK	S4N	SD
		S6	S6
		S9	S9
		SK	SK
		S36	36
		S40	40
		S40T	4T
		S40V	4V
		SB	SB

POSITION 10 - END CONNECTIONS	
Description	CODE
NPT - Threaded	1
ASME 150 Flanges (14" Face to Face Dimension) *	V
ASME 300 Flanges (14" Face to Face Dimension) *	W
PN40 Flanges (356 mm Face to Face Dimension) *	A
Opt. -31: BSPT - Taper Threaded	B
Opt. -31P: BSPP Parallel Threaded	P
Opt. -32: Plain End Extended Nipples *	E

POSITION 11 - RANGE SPRINGS		
SST Range Spring		CODE
psig	(Barg)	
2-15	(.14-1.0)	A
10-40	(.69-2.8)	B
30-80	(2.1-5.5)	C
70-150	(4.8-10.3)	D

POSITION 13 - FEATURE OPTIONS		
Description	OPTION	CODE
No Option	—	0
Handwheel & Locking Lever.	-3	3

POSITION 14 - SPRING CHAMBER OPTIONS		
Description	OPTION	CODE
Polyethylene Vented Plug	—	0
Stainless Steel Vented Plug	-25S	H

POSITION 15 - BODY OPTIONS		
Description	OPTION	CODE
No Option	—	0
Gauge Ports Included	-87	V

POSITION 16 - CERTIFICATE OPTIONS		
Description	OPTION	CODE
No Option	—	0
Oxygen Cleaning Per Cashco Specification S-1134	-55	M
Non-oxygen Cleaning Per Cashco Specification S-1542	-56	N

*** For information on ATEX see pages 8 & 9 on the IOM.**

Алматы (7273)495-231
 Ангарск (3955)60-70-56
 Архангельск (8182)63-90-72
 Астрахань (8512)99-46-04
 Барнаул (3852)73-04-60
 Белгород (4722)40-23-64
 Благовещенск (4162)22-76-07
 Брянск (4832)59-03-52
 Владивосток (423)249-28-31
 Владикавказ (8672)28-90-48
 Владимир (4922)49-43-18
 Волгоград (841)278-03-48
 Вологда (8172)26-41-59
 Воронеж (473)204-51-73
 Екатеринбург (343)384-55-89

Иваново (4932)77-34-06
 Ижевск (3412)26-03-58
 Иркутск (395)279-98-46
 Казань (843)206-01-48
 Калининград (4012)72-03-81
 Калуга (4842)92-23-67
 Кемерово (3842)65-04-62
 Киров (8332)68-02-04
 Коломна (4966)23-41-49
 Кострома (4942)77-07-48
 Краснодар (861)203-40-90
 Красноярск (391)204-63-61
 Курск (4712)77-13-04
 Курган (3522)50-90-47
 Липецк (4742)52-20-81

Магнитогорск (3519)55-03-13
 Москва (495)268-04-70
 Мурманск (8152)59-64-93
 Набережные Челны (8552)20-53-41
 Нижний Новгород (831)429-08-12
 Новокузнецк (3843)20-46-81
 Ноябрьск (3496)41-32-12
 Новосибирск (383)227-86-73
 Омск (3812)21-46-40
 Орел (4862)44-53-42
 Оренбург (353)237-68-04
 Пенза (8412)22-31-16
 Петрозаводск (8142)55-98-37
 Псков (8112)59-10-37
 Пермь (342)205-81-47

Ростов-на-Дону (863)308-18-15
 Рязань (4912)46-61-64
 Самара (846)206-03-16
 Санкт-Петербург (812)309-46-40
 Саратов (845)249-38-78
 Севастополь (8692)22-31-93
 Саранск (8342)22-96-24
 Симферополь (3652)67-13-56
 Смоленск (4812)29-41-54
 Сочи (862)225-72-31
 Ставрополь (8652)20-65-13
 Сургут (3462)77-98-35
 Сыктывкар (8212)25-95-17
 Тамбов (4752)50-40-97
 Тверь (4822)63-31-35

Тольятти (8482)63-91-07
 Томск (3822)98-41-53
 Тула (4872)33-79-87
 Тюмень (3452)66-21-18
 Ульяновск (8422)24-23-59
 Улан-Уде (3012)59-97-51
 Уфа (347)229-48-12
 Хабаровск (4212)92-98-04
 Чебоксары (8352)28-53-07
 Челябинск (351)202-03-61
 Череповец (8202)49-02-64
 Чита (3022)38-34-83
 Якутск (4112)23-90-97
 Ярославль (4852)69-52-93

Россия +7(495)268-04-70

Казахстан +7(7172)727-132

Киргизия +996(312)96-26-47