



ISO Registered Company

DA8-TB

02-20



MODEL DA8

DO-ALL SERIES VIII DIFFERENTIAL BACK PRESSURE REGULATOR

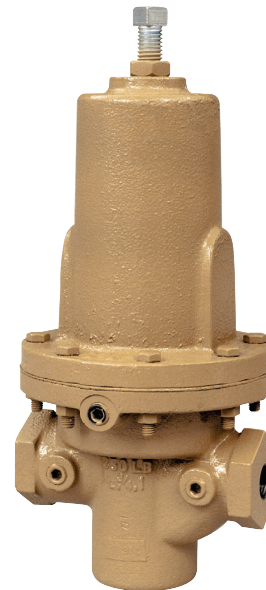

MODEL DA8

OVERVIEW

The Model DA8 is a differential back pressure regulators used to maintain a constant pressure differential between a fluid loading pressure (P_{LOAD}) piped to the spring chamber and the regulator's inlet pressure (P_1). In the Model DA8 the P_1 pressure is higher than the P_{LOAD} (Positive Bias). The amount of bias or differential pressure (ΔP_{DIFF}) is controlled by the user adjustable setting of the range spring in the spring chamber.

The regulator uses a flow-to-open, cage balanced trim. The diaphragm is isolated from the fluid flow path by a balancing piston, which allows the user to specify either internal or external sensing of the P_1 pressure.

FEATURES

- Versatile:** Four basic materials and multiple trim material combinations to select from.
- Tight Shutoff:** Multiple composition materials provide Class IV or VI inboard leakage rates. Designed as a soft-seated valve.
- Capacity:** Highest in the industry. Allows smaller body sizes than competitors in a majority of applications.
- Pressure Drop:** Highest in the industry when coupled with high flow capacity.
- Trim Design:** "DO-ALL" trim design provides FTO and pressure balancing for higher inlet pressure. Results in unmatched sensitivity and stability. Internals are cage-contained within easily removable quick change trim.
- Rangeability:** Basic valve gives outstanding rangeability due to close tolerances, balanced trim, and a broad range of elastomeric diaphragms and soft seats. Can be as high as 1000:1.
- Heavy-Duty Guiding:** Both top and bottom guided to maintain stability and increased diaphragm life.
- Failure Position:** DA8 fails closed on loss of P_1 pressure.



LINE SIZES AVAILABLE

1/2" (DN15), 3/4" (DN20), 1" (DN25), 1-1/4" (DN32), 1-1/2" (DN40), 2" (DN50), 3" (DN80), 4" (DN100)



END CONNECTIONS

NPT, FLANGED, BSPT, EXTENDED PIPE NIPPLES, 14" FACE TO FACE, EXTENSION TUBE ENDS



COMMON APPLICATIONS

CLEAN FLUIDS, ATMOSPHERIC INDUSTRIAL GASES, NATURAL GAS, AIR, OIL, WATER, STEAM, NON-CORROSIVE CHEMICAL SERVICES



DESIGN PRESSURE

INLET: 10-750 psig (0.69-51.7 Barg)
DROP: 5-750 psig (0.34-51.7 Barg)

Алматы (7273)495-231
Ангарск (3955)60-70-56
Архангельск (8192)63-90-72
Астрахань (8512)99-46-04
Барнаул (3852)73-04-60
Белгород (4722)40-23-64
Благовещенск (4162)22-76-07
Брянск (4832)59-03-52
Владивосток (423)249-28-31
Владикавказ (8672)28-90-48
Владимир (4922)49-43-18
Волгоград (844)278-03-48
Вологда (8172)26-41-59
Воронеж (473)204-51-73
Екатеринбург (343)384-55-89

Иваново (4932)77-34-06
Ижевск (3412)26-03-58
Иркутск (395)279-98-46
Казань (843)206-01-48
Калининград (4012)72-03-81
Калуга (4842)92-23-67
Кемерово (3842)65-04-62
Киров (8332)68-02-04
Коломна (4966)23-41-49
Кострома (4942)77-07-48
Краснодар (861)203-40-90
Красноярск (391)204-63-61
Курск (4712)77-13-04
Курган (3522)50-90-47
Липецк (4742)52-20-81

Магнитогорск (3519)55-03-13
Москва (495)268-04-70
Мурманск (8152)59-64-93
Набережные Челны (8552)20-53-41
Нижегний Новгород (831)429-08-12
Новокузнецк (3843)20-46-81
Новыйрськ (3496)41-32-12
Новосибирск (383)227-86-73
Омск (3812)21-46-40
Орел (4862)44-53-42
Оренбург (3532)37-68-04
Пенза (8412)22-31-16
Петрозаводск (8142)55-98-37
Псков (8112)59-10-37
Пермь (342)205-81-47

Ростов-на-Дону (863)308-18-15
Рязань (4912)46-61-64
Самара (846)206-03-16
Санкт-Петербург (812)309-46-40
Саратов (845)249-38-78
Севастополь (8692)22-31-93
Саранск (8342)22-96-24
Симферополь (3652)67-13-56
Смоленск (4812)29-41-54
Сочи (862)225-72-31
Ставрополь (8652)20-65-13
Сургут (3462)77-98-35
Сыктывкар (8212)25-95-17
Тамбов (4752)50-40-97
Тверь (4822)63-31-35

Тольятти (8482)63-91-07
Томск (3822)98-41-53
Тула (4872)33-79-87
Тюмень (3452)66-21-18
Ульяновск (8422)24-23-59
Улан-Удэ (3012)59-97-51
Уфа (347)229-48-12
Хабаровск (4212)92-98-04
Чебоксары (8352)28-53-07
Челябинск (351)202-03-61
Череповец (8202)49-02-64
Чита (3022)38-34-83
Якутск (4112)23-90-97
Ярославль (4852)69-52-93

Россия +7(495)268-04-70

Казахстан +7(7172)727-132

Киргизия +996(312)96-26-47

STANDARD / GENERAL SPECIFICATIONS

Body/Spring Chamber Materials

DI/DI	BRZ/BRZ *	SST/DI
CS/DI	BRZ/DI	SST/CS
CS/CS		SST/SST

* Through 2" (DN50) body size only.
 DI = Ductile Iron CS = Carbon Steel BRZ = Bronze
 SST = Stainless Steel

Body Sizes

1/2", 3/4", 1", 1-1/4", 1-1/2", 2", 3", 4"
 (DN15, 20, 25, 32, 40, 50 80, 100)

End Connections

Standard: Female NPT (screwed).
 ASME Flanged: 125#, 150#, 250#, 300#, 600#;
 DIN Flanged: PN16, PN25, PN40;
 (Integral Flanged Body unless listed under Opt.-30)
 Opt-31: British Standard Pipe Threads.
 Opt-32: Schedule 80 Extended Pipe Nipples.
 Opt-34: 14" Face to Face Flange Dimension.
 Opt-41: Extension Tube Ends.

Recommended Max. Useable Cv

Body Size		Diaphragm		Body Size		Diaphragm	
in	(DN)	Comp.	Metal	in	(DN)	Comp.	Metal
1/2"	(15)	3.6	3.1	2"	(50)	51	10.2
3/4"	(20)	7.2	3.1	3"	(80)	108	N/A
1"	(25)	12.7	3.1	4"	(100)	187	N/A
1-1/4"	(32)	20.7	5.0				
1-1/2"	(40)	25.5	5.0				
		Cv	Cv			Cv	Cv

See Table DAG-7 for Wide Open Cv Limits.
 See Tables 3A through 3D and 4A through 4C for Cv vs.
 Droop vs. Range Spring tables.

Inlet Pressure Range

Operating: 10–750 psig (.69-51.7 Barg).
 See Tables DAG-1A – 1F for design P vs. T limits.

Differential Pressure Range

1/2", 3/4" & 1" (DN15, DN20 & DN25):
 1 to 200 psid (.07 to 13.8 Bard)

1-1/4" & 1-1/2" (DN32 & DN40):
 1 to 125 psid (.07 to 8.6 Bard)

2" (DN50):
 1 to 90 psid (.07 to 6.2 Bard)

3" & 4" (DN80 & DN100):
 1 to 125 psid (0.07 to 8.6 Bard)

NOTE: Ranges may be limited by diaphragm selection.
 See Table 5

Pressure Drop Limits

5 - 750 psid (0.34 to 51.7 Bard)
 Function of service fluid, base trim material, diaphragm and
 dynamic seal design. See Table 5 and Table DAG-2, DAG-3
 & DAG-4.

Temperature Range

-425° to + 400° F (-254° to + 204° C]
 Limited by body/sp.ch. material combinations, and by
 elastomeric – diaphragm, seat, static seal, dynamic
 seal – materials. See Tables DAG-1A through 1F and Table
 DAG-5.
 Alternate "CS" Mat'l - Steel - ASTM A352 Gr. LCC - Minimum
 temperature -50 °F (-46 °C).

Inboard Leakage Rates

See Table DAG-10

Optional Constructions

<u>Opt-30:</u> Weld-on Flanges	<u>Opt-57:</u> Chlorine Cleaned
<u>Opt-31:</u> BSP End Conns	<u>Opt-65:</u> Flow-ThruSp.Chmb.
<u>Opt-32:</u> Ext. Pipe Nipples	<u>Opt-81:</u> Full Diaph Support
<u>Opt-34:</u> 14" F to F Flange Dim.	<u>Opt-85:</u> Extra Set Press Taps
<u>Opt-41:</u> Ext. Tube Ends	
<u>Opt-55:</u> Oxygen Cleaned	
<u>Opt-56:</u> Special Cleaned	

ABBREVIATIONS

FK = Fluorosilicone	NBR = Buna-N	PTFE = Polytetrafluoroethylene
FKM = Fluorocarbon	RTFE = Brz-fill TFE	V-TFE = Virgin TFE
EPR = Ethylene Propylene	GF-TFE = Glass-fill TFE	CTFE = Chlorotrifluoroethylene
BC = Neoprene	PA = PolyAll	3-ply (PTFE+FKM+PTFE)

MATERIAL SPECIFICATIONS

Body

- DI – ASTM A395
- CS – ASTM A216, Grade WCB.
 Alternate ASTM A352 Gr. LCC
- BRZ – ASTM B62, Alloy 83600,
- SST – ASTM A351, Grade CF3M.

See DAG-1A through DAG-1F for material specs.

Spring Chamber

- DI – ASTM A395
- CS – Sizes 1/2" - 2" ASTM A216 Gr. WCB;
 Alternate ASTM A352 Gr. LCC
 Sizes 3" & 4" ASTM A516 Gr. 55, A106 Gr. B;
- BRZ – ASTM B62, Alloy 83600.
- SST – Sizes 1/2" - 2" ASTM A351 Gr. CF3M;
 Sizes 3" & 4" ASTM A479 Gr. 316L, A312 Gr. 316L;

Diaphragm *

- Elastomeric – BC, EPR, FKM, FK, NBR, FKM+TFE,
 3-ply(PTFE+FKM+PTFE).
- Metallic – Be-Cu. (only 1/2" - 2" sizes)

Metallic Trim *

17-4PH SST, 316L SST, Nickel-Copper Alloy (Monel).
See Table 2.

Seat *

PolyAll, V-TFE, GF-TFE, CTFE, FKM

Static Seals (See Fig. DAG-F1) *

RTFE, NBR, FKM, FK, EPR, (All Sizes)
SST/TFE (1/2" - 2") (DN15 - 50)
V-TFE (3" - 4") (DN80 - 100)

Dynamic Seals (See Fig. DAG-F1) *

- Type CP – TFE cap+ NBR, FKM, EPR o-ring seal.
- Type UC – V-TFE u-cup seal with 316L SST energizer.
- Type PR – GF-TFE piston ring assembly seal with
 17-7PH SST energizer.

Painting

Standard: All non-corrosion resistant portions to be painted with corrosion resistant epoxy paint per Cashco Spec #S-1606.

* See Product Coder for acceptable combinations
Monel™, and Inconel® are registered trade names:
Monel™ is a mark owned by International Nickel Co.
Inconel® is a mark owned by International Nickel Co.

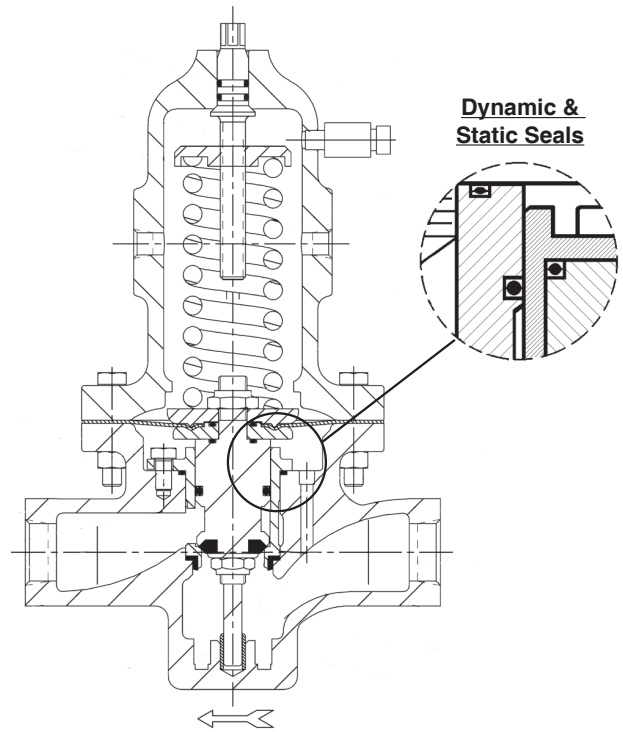

Reverse Flow Direction Composition Diaphragm
FTO – Flow-to-Open
Balanced at Outlet
Trim Balanced to Outlet Pressure Variations

FIGURE 1

OPTION SPECIFICATIONS

OPT-30: **WELDED FLANGED CONNECTIONS.** CS, SST or HC body materials only. 1/2"-2" (DN15-50) body sizes only (no 1-1/4" (DN32) size). Welded-on flange of same general chemistry as body.

Weld-On Flanges		
Sizes	Body Material	ASME Pressure Class
1/2" - 3/4"	CS, SST	150, 300, 600
1"	CS, SST	600
Sizes	Body Material	ISO Pressure Class
DN15-50	CS, SST	PN40 RF
DN80-100	CS, SST	PN16, 25, 40 RF
^ For 1/2" - 2" sizes, CS & SST, metal diaphragm only		

NOTES: 1. The body P vs. T ratings are the limiting variables for flanged end connections, unless further restricted by ASME B16.5.
2. No post-weld stress relieving performed.

OPT-31: **BSPT END CONNECTIONS.** British Standard Pipe threads per ISO 7/1; used as an alternate to NPT ends. 1/2" - 2" (DN15-50) sizes only.

OPT-32: **EXTENDED PIPE NIPPLES.** Sch. 80 extension pipe nipples available for CS and SST bodies; for body sizes 1/2" - 2" (DN15-50) only.

OPT-34: **SPECIAL 14" FACE TO FACE DIMENSION FOR FLANGED END CONNECTIONS.** Sizes 1/2" - 1" & 1-1/2" only. See Opt.-30 for standard face to face dimension.

OPT-41: **EXTENDED TUBE END CONN.** SST body material only. Body sizes 1/2"-1" (DN15-25), 1-1/2" & 2" (DN40-50) only. SST extension tubes are welded to body, ending in tube diameters with 0.065 inch (1.65 mm) wall thickness. **NOT FOR HIGH PURITY REQUIREMENTS.**

OPT-55: **SPECIAL CLEANING - GOX.** BRZ or SST body materials only. Cleaning, assembly and packaging per Cashco Spec #S-1134, making unit suitable for Oxygen Service. **NOTE: Design Pressure Rating shall not exceed 375 psig (25.8 Barg) when body/topworks material is SST and process medium is oxygen.**

OPT-56: **SPECIAL CLEANING.** Cleaning per Cashco Spec. #S-1542 for all body & spring chamber materials. Higher cleaning level than standard commercial cleaning. **NOT suitable for Oxygen Service.**

OPT-57: **SPECIAL CLEANING - Chlorine.** CS or SST materials only. Cleaning per Cashco Spec. #S-1589. For chlorine gas/liquid service.

OPT-65: **FLOW-THRU SPRING CHAMBER.** Spring chamber provided with two female NPT connections on spring chamber, allowing loading pressurizing fluid to be recirculated. Recommended for heavy oils with high paraffin content. CS spring chamber only. Tapped connection sizes dependent on body size.

OPT-81: **FULL DIAPHRAGM SUPPORT CONSTRUCTION.** Incorporates top & bottom diaphragm support that allows reaching higher fluid pressures on the underside and top side of diaphragm. Sizes 1/2"-2" (DN15-50) only. See Table 5.

OPT-85: **PRESSURE TAPS.** Provides second set of inlet and outlet 1/4" (DN8) - FNPT taps with plugs (same basic material as body) on backside of body. Includes second external sensing port tap. See page 21 for details on tap location for both STD. and Opt -85.

TECHNICAL SPECIFICATIONS

**TABLE 1
RANGE SPRINGS**

Body Size in. (DN)	Spring Range psid	Body Size in. (DN)	Spring Range psid
1/2" (15) 3/4" (20) 1" (25)	1-5* 1-10**	2" (50)	1-5* 1-10**
	5-20 10-35 20-80 30-150 70-200		5-15 10-30 15-50 30-90
1-1/4" (32) 1-1/2" (40)	1-5* 1-10**	3" (80) 4" (100)	1-10
	5-20 15-45 10-70 40-175		5-20 10-40 10-70 40-125

* Composition diaphragm construction ONLY.
 ** Metal diaphragm for set point pressure ≥ 5 psid (.34 Bard).
 METRIC CONVERSION: psid / 14.5 = Bard

**TABLE 2
METALLIC TRIM MATERIAL COMBINATIONS**

PART	TRIM DESIGNATION			
	S	P	M	T
Plug / Guide Bearing	316L SST	17-4 PH SST	Monel†	17-4 PH SST
Cage	316L SST	316L SST	Monel†	Monel†
Body Bushing	Monel†	17-4 PH SST	Monel†	Monel†

† See Page 3 for registered trade name information.

TABLE 3A
FULL PORT FLOW CAPACITY – Cv
COMPOSITION DIAPHRAGM
 $F_L = 0.90$

Differential Pressure ΔP Diff (psid)	COMPOSITION DIAPHRAGM															Range Spring psid
	BODY SIZE - 1/2" (DN15)					BODY SIZE - 3/4" (DN20)					BODY SIZE - 1" (DN25)					
	10%	20%	30%	40%	50%	10%	20%	30%	40%	50%	10%	20%	30%	40%	50%	
1	1.15	1.75	2.38	2.97	3.53	1.15	1.75	2.38	2.97	3.53	1.28	2.34	3.40	4.40	5.34	1-5
3	2.67	2.77	2.91	3.03	3.16	3.44	3.95	4.85	5.70	6.50	3.83	5.27	6.93	8.49	9.95	
5	3.52	3.54	3.56	3.58	3.60	4.97	7.14	7.16	7.18	7.20	5.53	9.60	12.70	12.73	12.75	
1	0.56	0.86	1.15	1.42	1.67	0.56	0.86	1.15	1.42	1.67	0.60	1.11	1.72	2.29	2.83	1-10
5	2.64	3.54	3.56	3.58	3.60	2.80	4.90	6.50	7.18	7.20	3.66	5.10	6.67	8.15	9.54	
10	3.52	3.54	3.56	3.58	3.60	4.76	7.14	7.16	7.18	7.20	5.23	9.15	12.10	12.73	12.75	
5	2.30	3.54	3.56	3.58	3.60	2.30	4.00	5.30	6.30	7.05	2.55	4.08	5.23	6.31	7.32	5-20
10	3.52	3.54	3.56	3.58	3.60	3.64	6.40	7.16	7.18	7.20	4.04	6.59	8.67	10.60	12.50	
15	3.52	3.54	3.56	3.58	3.60	4.40	7.14	7.16	7.18	7.20	4.89	9.10	11.30	12.73	12.75	
20	3.52	3.54	3.56	3.58	3.60	6.39	7.14	7.16	7.18	7.20	7.10	12.40	12.70	12.73	12.75	
10	1.11	1.79	2.53	3.24	3.60	1.11	1.79	2.53	3.24	3.90	1.23	2.38	3.61	4.77	5.86	10-35
20	1.96	2.68	3.05	3.40	3.60	2.45	3.83	5.09	6.28	7.20	2.72	5.10	7.27	9.30	11.20	
30	3.18	3.54	3.56	3.58	3.60	3.98	5.87	7.16	7.18	7.20	4.42	7.82	10.30	12.10	12.75	
35	3.40	3.54	3.56	3.58	3.60	4.59	6.90	7.16	7.18	7.20	5.10	8.50	11.10	12.73	12.75	
20	0.84	1.40	1.94	2.44	2.91	0.84	1.40	1.94	2.44	2.91	0.94	1.87	2.76	3.60	4.39	20-80
40	1.42	2.62	3.56	3.58	3.60	1.42	2.62	3.87	5.04	6.15	1.57	3.49	5.53	7.44	9.25	
60	2.39	3.24	3.56	3.58	3.60	2.98	4.62	6.07	7.18	7.20	3.32	6.16	8.67	11.00	12.17	
80	3.33	3.54	3.56	3.58	3.60	4.17	5.50	6.50	7.18	7.20	4.63	8.10	10.70	12.60	12.75	
30	0.77	1.28	1.79	2.26	2.72	0.77	1.28	1.79	2.26	2.72	0.85	1.70	2.55	3.35	4.10	30-150
50	1.34	2.24	2.98	3.58	3.60	1.34	2.24	2.98	3.67	4.32	1.49	2.98	4.25	5.45	6.58	
75	2.30	3.51	3.56	3.58	3.60	2.30	3.51	4.58	5.59	6.53	2.55	4.68	6.55	8.30	9.96	
100	2.91	3.51	3.56	3.58	3.60	2.91	4.46	5.65	6.77	7.20	3.23	5.95	8.08	10.10	12.00	
125	3.06	3.54	3.56	3.58	3.60	3.83	5.58	6.80	7.18	7.20	4.25	7.44	9.80	11.60	12.75	
150	3.52	3.54	3.56	3.58	3.60	4.21	6.20	7.16	7.18	7.20	5.10	8.90	11.70	12.73	12.75	
70	0.58	1.44	2.32	3.15	3.60	0.58	1.44	2.32	3.15	3.93	1.00	2.00	3.00	4.00	5.00	70-200
100	1.84	3.03	3.56	3.58	3.60	1.84	3.03	4.02	4.96	5.83	2.04	4.04	5.74	7.34	8.84	
125	2.49	3.52	3.56	3.58	3.60	2.49	3.89	5.06	6.15	6.80	2.76	5.19	7.23	9.14	10.90	
150	2.91	3.54	3.56	3.58	3.60	2.91	4.59	5.53	6.42	7.20	3.23	6.12	7.91	9.58	11.20	
175	3.52	3.54	3.56	3.58	3.60	3.56	5.68	6.74	7.18	7.20	3.95	7.57	10.30	12.34	12.75	
200	3.52	3.54	3.56	3.58	3.60	4.28	7.14	7.16	7.18	7.20	4.30	7.60	10.30	12.30	12.75	

METRIC CONVERSION FACTORS: psid / 14.5 = Bard; $C_v / 1.16 = k_v$

TABLE 3B
FULL PORT FLOW CAPACITY – Cv
COMPOSITION DIAPHRAGM $F_L = 0.90$

Differential Pressure ΔP Diff (psid)	COMPOSITION DIAPHRAGM										Range Spring psid
	BODY SIZE - 1 1/4" (DN32)					BODY SIZE - 1 1/2" (DN40)					
	10%	20%	30%	40%	50%	10%	20%	30%	40%	50%	
1	1.78	2.91	3.83	4.69	5.50	1.87	3.23	4.51	5.70	6.83	1-10
5	3.91	6.67	9.27	11.70	14.00	4.12	7.40	11.00	14.30	17.50	
10	6.16	13.30	18.50	20.00	20.70	6.72	14.00	19.00	24.00	25.50	
5	2.26	4.05	5.59	7.04	8.40	2.38	4.51	6.59	8.55	10.40	5-20
10	4.85	8.67	11.50	14.10	16.60	5.10	9.69	13.50	17.10	20.50	
15	7.30	13.00	17.00	19.60	20.70	8.00	16.80	22.80	25.00	25.50	
20	9.70	17.30	20.00	20.30	20.70	10.00	18.00	24.50	25.00	25.50	
15	3.79	6.89	9.10	11.20	13.10	4.00	7.65	10.70	13.60	16.30	15-45
25	6.30	11.10	14.90	18.40	19.60	6.63	12.40	17.50	22.30	25.50	
35	8.76	15.20	19.60	19.60	0.00	9.27	16.90	23.40	25.00	25.50	
45	11.40	19.80	20.00	20.30	20.70	12.80	21.00	24.50	25.00	25.50	
15	1.80	3.00	4.20	5.30	6.30	1.95	3.20	4.50	5.75	7.10	10-70
30	3.63	6.35	8.67	10.90	12.90	3.83	7.06	10.20	13.20	15.90	
50	6.26	10.70	14.00	17.10	19.60	6.59	12.00	16.60	20.90	24.90	
70	8.50	14.80	20.00	20.30	20.70	9.00	15.00	23.00	25.00	25.50	
40	2.18	4.36	5.99	7.53	8.97	2.30	4.85	7.06	9.13	11.10	40-125
50	3.23	5.66	7.58	9.39	11.10	3.40	6.29	8.93	11.40	13.70	
75	4.44	7.73	10.50	13.00	15.40	4.68	8.59	12.30	15.80	19.10	
100	5.85	9.95	13.10	16.00	18.80	6.16	11.10	15.50	19.50	23.40	
125	7.27	12.40	16.40	20.00	20.70	7.65	13.90	19.30	24.40	25.50	

TABLE 3C
FULL PORT FLOW CAPACITY – Cv
COMPOSITION DIAPHRAGM $F_L = 0.90$

Differential Pressure ΔP Diff (psid)	COMPOSITION DIAPHRAGM					Range Spring psid
	BODY SIZE - 2" (DN50)					
	10%	20%	30%	40%	50%	
1	4.25	10.60	14.90	18.90	22.60	1-10
5	13.90	25.70	38.30	50.00	51.00	
10	22.10	41.00	49.00	50.00	51.00	
5	7.23	12.80	18.30	23.50	28.40	5-15
10	12.30	24.70	37.00	48.60	51.00	
15	19.00	36.00	49.00	50.00	51.00	
10	4.17	8.50	12.80	16.70	20.50	10-30
20	10.00	17.00	27.70	37.80	47.20	
30	15.00	25.00	38.00	50.00	51.00	
15	2.55	5.95	9.35	12.50	15.60	15-50
25	5.10	9.78	14.60	19.20	23.50	
35	7.40	15.10	22.50	29.50	36.00	
50	10.60	19.00	29.00	38.00	47.00	
30	3.40	5.87	8.93	11.80	14.50	30-90
60	6.97	12.80	18.70	24.30	29.60	
90	10.20	19.00	28.00	36.00	44.00	

METRIC CONVERSION FACTORS: psid / 14.5 = Bard; $C_v / 1.16 = k_v$

TABLE 3D
FULL PORT FLOW CAPACITY – Cv
COMPOSITION DIAPHRAGM $F_L = 0.90$

Differential Pressure ΔP Diff (psid)	COMPOSITION DIAPHRAGM										Range Spring psid
	BODY SIZE - 3" (DN80)					BODY SIZE - 4" (DN100)					
	10%	20%	30%	40%	50%	10%	20%	30%	40%	50%	
1	12.80	20.00	27.00	33.00	38.00	12.80	20.00	27.00	33.00	38.00	1-10
3	17.00	34.00	51.00	64.00	77.00	17.00	34.00	51.00	67.00	82.00	
5	24.70	45.10	63.00	80.00	95.00	29.80	60.00	89.00	117.00	144.00	
10	53.00	90.00	102.00	105.00	108.00	64.00	110.00	150.00	185.00	187.00	
5	20.80	36.50	52.00	70.00	83.00	25.50	42.50	61.00	79.00	95.00	5-20
10	38.00	74.00	98.00	104.00	108.00	40.80	78.00	102.00	124.00	145.00	
15	56.00	99.00	102.00	105.00	108.00	64.00	106.00	136.00	164.00	187.00	
20	77.00	100.00	102.00	105.00	108.00	85.00	150.00	180.00	184.00	187.00	
10	20.00	39.60	56.00	70.00	83.00	21.30	40.80	57.00	72.00	86.00	10-40
20	41.00	51.00	68.00	84.00	99.00	43.40	86.00	116.00	114.00	170.00	
30	56.00	74.00	96.00	102.00	108.00	60.00	108.00	145.00	179.00	187.00	
40	81.00	94.00	102.00	105.00	108.00	89.00	150.00	180.00	184.00	187.00	
10	10.30	19.80	29.50	37.70	47.00	10.50	20.00	29.80	38.00	47.00	10-70
30	22.00	43.00	63.00	81.00	95.00	23.40	45.10	66.00	86.00	105.00	
50	37.00	72.00	100.00	104.00	108.00	41.20	80.00	112.00	143.00	171.00	
70	51.00	96.00	100.00	104.00	108.00	55.00	102.00	142.00	170.00	187.00	
40	19.60	35.20	46.00	57.50	68.00	21.30	36.10	48.00	60.00	71.00	40-125
50	24.40	43.20	57.00	71.00	85.00	25.10	40.80	57.00	72.00	86.00	
75	33.00	55.00	75.00	94.50	108.00	34.00	57.00	78.00	98.00	117.00	
100	38.00	71.00	96.00	105.00	108.00	40.80	71.00	97.00	122.00	145.00	
125	47.00	89.00	102.00	105.00	108.00	48.50	90.00	126.00	158.00	186.00	

METRIC CONVERSION FACTORS: psid / 14.5 = Bard; $C_v / 1.16 = k_v$

TABLE 4A
FULL PORT FLOW CAPACITY – Cv
METAL DIAPHRAGM $F_L = 0.90$

Differential Pressure ΔP_{Diff} (psid)	Cv Capacity @ % Droop															Range Spring psid
	BODY SIZE - 1/2" (DN15)					BODY SIZE - 3/4" (DN20)					BODY SIZE - 1" (DN25)					
	10%	20%	30%	40%	50%	10%	20%	30%	40%	50%	10%	20%	30%	40%	50%	
5	1.00	1.88	2.75	2.95	3.00	1.00	1.88	2.75	2.95	3.00	1.00	1.88	2.75	2.95	3.00	5-20
10	1.60	2.80	2.85	2.95	3.00	1.60	2.80	2.85	2.95	3.00	1.60	2.80	2.85	2.95	3.00	
15	2.00	2.80	2.85	2.95	3.00	2.00	2.80	2.85	2.95	3.00	2.00	2.80	2.85	2.95	3.00	
20	2.50	2.80	2.85	2.95	3.00	2.50	2.80	2.85	2.95	3.00	2.50	2.80	2.85	2.95	3.00	
10	0.55	1.03	1.51	1.99	2.45	0.55	1.03	1.51	1.99	2.45	0.55	1.03	1.51	1.99	2.45	10-35
20	1.05	1.97	2.89	2.95	3.00	1.05	1.97	2.89	2.95	3.00	1.05	1.97	2.89	2.95	3.00	
30	1.55	2.80	2.85	2.95	3.00	1.55	2.80	2.85	2.95	3.00	1.55	2.80	2.85	2.95	3.00	
35	1.93	2.80	2.85	2.95	3.00	1.93	2.80	2.85	2.95	3.00	1.93	2.80	2.85	2.95	3.00	
20	0.40	0.75	1.10	1.44	1.78	0.40	0.75	1.10	1.44	1.78	0.40	0.75	1.10	1.44	1.78	20-80
40	0.80	1.50	2.20	2.89	3.00	0.80	1.50	2.20	2.89	3.00	0.80	1.50	2.20	2.89	3.00	
60	1.10	2.07	2.85	2.95	3.00	1.10	2.07	2.85	2.95	3.00	1.10	2.07	2.85	2.95	3.00	
80	1.50	2.80	2.85	2.95	3.00	1.50	2.80	2.85	2.95	3.00	1.50	2.80	2.85	2.95	3.00	
30	0.30	0.56	0.83	1.08	1.34	0.30	0.56	0.83	1.08	1.34	0.30	0.56	0.83	1.08	1.34	30-150
50	0.50	0.94	1.38	1.81	2.23	0.50	0.94	1.38	1.81	2.23	0.50	0.94	1.38	1.81	2.23	
75	0.70	1.32	1.93	2.53	3.00	0.70	1.32	1.93	2.53	3.00	0.70	1.32	1.93	2.53	3.00	
100	0.95	1.79	2.61	2.95	3.00	0.95	1.79	2.61	2.95	3.00	0.95	1.79	2.61	2.95	3.00	
125	1.20	2.26	2.85	2.95	3.00	1.20	2.26	2.85	2.95	3.00	1.20	2.26	2.85	2.95	3.00	
150	1.40	2.63	2.85	2.95	3.00	1.40	2.63	2.85	2.95	3.00	1.40	2.63	2.85	2.95	3.00	
70	0.50	0.94	1.38	1.81	2.23	0.50	0.94	1.38	1.81	2.23	0.50	0.94	1.38	1.81	2.23	70-200
100	0.80	1.50	2.20	2.89	3.00	0.80	1.50	2.20	2.89	3.00	0.80	1.50	2.20	2.89	3.00	
125	1.10	2.07	2.85	2.95	3.00	1.10	2.07	2.85	2.95	3.00	1.10	2.07	2.85	2.95	3.00	
150	1.30	2.44	2.85	2.95	3.00	1.30	2.44	2.85	2.95	3.00	1.30	2.44	2.85	2.95	3.00	
175	1.45	2.73	2.85	2.95	3.00	1.45	2.73	2.85	2.95	3.00	1.45	2.73	2.85	2.95	3.00	
200	1.60	2.80	2.85	2.95	3.00	1.60	2.80	2.85	2.95	3.00	1.60	2.80	2.85	2.95	3.00	

METRIC CONVERSION FACTORS: psid / 14.5 = Bard; $C_v / 1.16 = k_v$

TABLE 4B
FULL PORT FLOW CAPACITY – Cv
DA8 - METAL DIAPHRAGM
F L = 0.90

Differential Pressure ΔP Diff (psid)	Cv Capacity @ % Droop										Range Spring psid
	BODY SIZE - 1 1/4" (DN32)					BODY SIZE - 1 1/2" (DN40)					
	10%	20%	30%	40%	50%	10%	20%	30%	40%	50%	
5	1.30	2.44	3.43	4.25	4.87	1.30	2.44	3.43	4.25	4.87	5-20
10	2.20	4.14	4.80	4.90	5.00	2.20	4.14	4.80	4.90	5.00	
15	3.00	4.70	4.80	4.90	5.00	3.00	4.70	4.80	4.90	5.00	
20	3.75	4.70	4.80	4.90	5.00	3.75	4.70	4.80	4.90	5.00	
15	1.10	2.07	2.90	3.59	4.12	1.10	2.07	2.90	3.59	4.12	15-45
25	1.75	3.29	4.61	4.90	5.00	1.75	3.29	4.61	4.90	5.00	
35	2.40	4.51	4.80	4.90	5.00	2.40	4.51	4.80	4.90	5.00	
45	3.00	4.70	4.80	4.90	5.00	3.00	4.70	4.80	4.90	5.00	10-70
10	1.05	1.97	2.77	3.43	3.93	1.05	1.97	2.77	3.43	3.93	
30	3.02	4.70	4.80	4.90	5.00	3.02	4.70	4.80	4.90	5.00	
50	4.60	4.70	4.80	4.90	5.00	4.60	4.70	4.80	4.90	5.00	
70	4.60	4.70	4.80	4.90	5.00	4.60	4.70	4.80	4.90	5.00	40-125
40	2.04	3.84	4.80	4.90	5.00	2.04	3.84	4.80	4.90	5.00	
50	2.59	4.70	4.80	4.90	5.00	2.59	4.70	4.80	4.90	5.00	
75	4.08	4.70	4.80	4.90	5.00	4.08	4.70	4.80	4.90	5.00	
100	4.60	4.70	4.80	4.90	5.00	4.60	4.70	4.80	4.90	5.00	
125	4.60	4.70	4.80	4.90	5.00	4.60	4.70	4.80	4.90	5.00	

METRIC CONVERSION FACTORS:
psid / 14.5 = Bard; Cv / 1.16 = kv

TABLE 4C
FULL PORT FLOW CAPACITY – Cv
DA8 - METAL DIAPHRAGM
F L = 0.90

Differential Pressure ΔP Diff (psid)	Cv Capacity @ % Droop					Range Spring psid
	BODY SIZE - 2" (DN50)					
	10%	20%	30%	40%	50%	
5	1.90	3.57	5.01	6.21	7.11	5-15
10	3.40	6.39	8.96	9.80	10.00	
15	5.50	9.20	9.60	9.80	10.00	
10	2.70	5.08	7.12	8.82	10.00	10-30
20	5.20	9.00	9.60	9.80	10.00	
30	7.90	9.40	9.60	9.80	10.00	
15	4.10	7.71	9.60	9.80	10.00	15-50
25	6.60	9.40	9.60	9.80	10.00	
35	9.20	9.40	9.60	9.80	10.00	
50	9.20	9.40	9.60	9.80	10.00	
30	5.10	9.40	9.60	9.80	10.00	30-90
60	9.20	9.40	9.60	9.80	10.00	
90	9.20	9.40	9.60	9.80	10.00	

TABLE 5
MAXIMUM DIAPHRAGM RATING *
psig (BARG)

NOTE: The below ratings may be further "derated" by limitations through the Pressure Equipment Directive (2014/68/EU).

DIAPHRAGM MATERIAL	BODY SIZE 1/2" - 2"		BODY SIZE 3" - 4"
	STD DIAPHRAGM CONSTRUCTION	**OPT-81 FULL DIAPHRAGM SUPPORT	STD DIAPHRAGM CONSTRUCTION
	P ₁ MAX	P ₁ MAX	P ₁ MAX
BC, EPR	1250 (86.1)	1250 (86.1)	800 (55.1)
NBR	450 (31.0)	1250 (86.1)	300 (20.6)
FKM, FKM+TFE, FK	700 (48.2)	1250 (86.1)	550 (37.9)
3-ply (PTFE+FKM+PTFE) ***	125 (8.6)	125 (8.6)	125 (8.6)
METAL Be-Cu	1500 (103)	NA	NA

*Maximum setting of pressure safety device – safety relief valve or rupture disc.
** Not Available for DI/DI, BRZ/DI, BRZ/BRZ,CS/DI & SST/DI construction.
*** For Steam applications.
NA = Not Available

DAG TECHNICAL APPENDIX INDEX

<u>TABLE</u>	<u>TITLE</u>	<u>PAGE</u>
DAG-1A	DI – Press vs Temp vs End Conn Ratings	12
DAG-1B	BRZ – Press vs Temp vs End Conn Ratings	13
DAG-1D	CS – Design Inlet/Outlet - DA8	14
DAG-1F.....	SST – Design Inlet/Outlet - DA8.....	14
DAG-2.....	Max Pressure Drop - Comp Seat	15
DAG-3.....	Max Pressure Drop - Dynamic Seal Design.....	15
DAG-4.....	Max Pressure Drop - Basic Trim Mat'ls.....	15
DAG-5.....	Temperature Limits – Elastomer Mat'ls.....	16
DAG-7.....	Back Pressure Max Capacity - Plug Wide Open.....	17
DAG-10.....	Inboard Leakage Ratings	17
DAG-12.....	Back Press Recommended Velocity Limits.....	17
DAG-14.....	Recommended Internal Materials - Liquids.....	18
DAG-14.....	Recommended Internal Materials - Gases.....	18
DAG-14.....	Supplement - Chemical Resistance	19

<u>FIGURE</u>	<u>TITLE</u>	<u>PAGE</u>
DAG-F1.....	Dynamic/Static Seals	20
DAG-F2.....	Location of Body/Spring Chamber Taps	21

TABLE DAG-1A
DI – DUCTILE IRON
BODY / TOPWORKS MATERIAL SPECIFICATIONS
DESIGN PRESSURE vs. TEMPERATURE vs. END CONNECTION RATINGS
(To ASME B16.1 for Flanged and B16.4 for NPT Connections per Cast Iron Rating)

Material Specifications (Body / Topworks)		End Connection – Inlet & Outlet					
Description (Abbr.)	ASTM No.	Temperature °F	Working Pressure – psig				
			End Connection – Pressure Class				
			NPT	125# FF	250# RF		
DI/DI (Note 1)	A395/ A395	-20° to +150°	400	200	500		
		200°	370	190	460		
		225°	355	180	440		
		250°	340	175	415		
		300°	310	165	375		
		350°	300	150	335		
		400°	250	140	290		
		406°	250	140	290		
			400 WOG, 250 S	225 WOG, 125 S	400 WOG, 250 S		
				Working Pressure – Barg			
				End Connection – Pressure Class			
					NPT	125# FF	250# RF
				-29° to +65°	27.6	13.8	34 .5
				107	24.5	12.5	30.2
				120°	23.4	12.1	28.7
		150°	21.2	11.2	25.7		
		177°	19.2	10.6	23.8		
		204°	17.5	9.6	20.3		

NOTE 1: Whenever body and topworks materials are mixed, the P vs. T ratings that should be applied are those which are lowest of the two materials.

Example: CS body, DI topworks; NPT end connections, 200°F temperature.

Because the topworks is not “end flanged”, use the DI limits of “400 PSIG CWP 370/200F” from above to compare to CS limits from DAG-1C values. The DI limits are lower, so ratings from DAG-1A MUST be used as the limits.

NOTE 2: Unless stated otherwise, design pressure is Maximum Allowable Working Pressure (MAWP) for Inlet and Outlet.

**TABLE DAG-1B
BRZ – BRONZE
BODY / TOPWORKS MATERIAL SPECIFICATIONS**

**DESIGN PRESSURE vs. TEMPERATURE vs. END CONNECTION RATINGS
(Per ASME B16.24 for Flanged and B16.15 for NPT Connections)**

Material Specifications (Body / Topworks)		End Connection – Inlet & Outlet (Note 2)					
Description (Abbr.)	ASTM No.	Temperature °F	Working Pressure –psig				
			End Connection – Pressure Class				
			NPT	150# FF	300# FF		
BRZ/BRZ (Note 1)	B62, Alloy C83600/B62, Alloy C83600	-325° to +150° *	500	225	500		
		175°	390	220	480		
		200°	385	210	465		
		225°	375	205	445		
		250°	365	195	425		
		300°	335	180	390		
		350°	300	165	350		
		400°	250	150	315		
		406°	250	150	315		
				Working Pressure – Barg			
				End Connection – Pressure Class			
				NPT	150# FF	300# FF	
				-198° to +65° *	34.5	15.5	34.5
				107°	25.8	14.0	30.8
				120°	25.1	13.5	29.5
				150°	23.0	12.4	26.8
				177°	20.4	11.3	24.0
		204°	17.8	10.3	21.4		

NOTE 1: Whenever body and topworks materials are mixed, the P vs. T ratings that should be applied are those which are lowest of the two materials.

Example: BRZ body, DI topworks; NPT end connections, ambient temperature.
Because the topworks is not “end flanged”, use the DI limits of “400 PSIG CWP 370/200F” from DAG-1A to compare to above DAG-1B values. The DI limits are lower, so ratings from DAG-1A MUST be used as the limits.

NOTE 2: Unless stated otherwise, design pressure is Maximum Allowable Working Pressure (MAWP) for Inlet and Outlet.

* See Minimum Temperature Ratings Table below.

**DESIGN PRESSURE RATING
AT MIN. TEMPERATURE**

Regulator Function	Material Specifications (Body / Topworks - Connections) Description (Abbr.)	Pressure at Min. Temperature
Back Pressure Relief	BRZ/BRZ	Inlet - 500 psig CWP to -325°F (-198°C)
		Outlet - 500 psig CWP to -325°F (-198°C)
	SST/SST - NPT, BSP, Ext. Nipples, Tube Ends and 600# Flgs	Inlet - 625 psig CWP to -425°F (-254°C)
		Outlet - 625 psig CWP to -425°F (-254°C)

Body Material Specifications

Cast Steel A216 Gr.WCB or Steel Weldment A216 Gr. WCB w/ forged flanges A105

Alternate Material: Cast Steel A352 Gr. LCC or Steel Weldment A352 Gr. LCC w/ forged flanges A350 Gr. LF6 Class 2

Topworks Material Specifications

Cast Steel A216 Gr. WCB or Steel Weldment A516 Gr. 55 & A105

Alternate Material: Cast Steel A352 Gr. LCC

DESIGN PRESSURE vs. TEMPERATURE vs. END CONNECTION RATINGS

(Per ASME B16.5 and B16.34) See NOTE 1

TABLE DAG-1D DESIGN PRESSURE (BOTH INLET AND OUTLET) FOR DA8 in PSIG (BARG)				
CONSTRUCTION	END CONNECTIONS			
	STD DIAPHRAGM	ALL		Opt-81 (Full Support Diaph.) DA8
DESIGN TEMP. RANGE: Deg F (Deg C) **	NPT, BSP, 600#, EXTD NIPP	150#	300#	NPT, BSP. 600#, EXTD NIPP
-20 to +100 (-29 to +38)	750 (51.7)	285 (19.6)	740 (51.1)	1350 (93.0)
-20 to +200 (-29 to +93)	680 (47.1)	260 (17.9)	680 (47.1)	1350 (93.0)
-20 to +300 (-29 to +149)	655 (45.1)	230 (15.8)	655 (45.1)	1310 (90.3)
-20 to +400 (-29 to +204)	635 (43.6)	200 (13.7)	635 (43.8)	1265 (87.3)

** Alternate Mat'l: ASTM 352 Gr. LCC Min. Temperature -50 °F(-46°C).

Cast Stainless Steel A351 Gr.CF3M or Stainless Steel Weldment A315 Gr. CF3M w/ forged flanges A182 Gr. F 316L

Topworks Material Specifications

Cast Stainless Steel A351 Gr.CF3M or Stainless Steel Weldment A312 Gr. 316/316L, A479 Gr. 316/316L

DESIGN PRESSURE vs. TEMPERATURE vs. END CONNECTION RATINGS

(Per ASME B16.5 and B16.34) See NOTE 1 using SST specifications; & NOTE 2

TABLE DAG-1F DESIGN PRESSURE (BOTH INLET AND OUTLET) FOR DA8 in PSIG (BARG)				
CONSTRUCTION *	END CONNECTIONS			
	STD DIAPHRAGM	ALL		Opt-81 (Full Support Diaph.) DA8
DESIGN TEMP. RANGE: Deg F (Deg C)	NPT, BSP, 600#, EXTD NIPP, TUBE	150#	300#	NPT, BSP. 600#, EXTD NIPP, TUBE
-425 to +100 (-254 to +38)	625 (43.0)	275 (19.0)	625 (43.0)	1125 (77.5)
-20 to +200 (-29 to +93)	620 (42.3)	235 (16.5)	620 (42.3)	1125 (77.5)
-20 to +300 (-29 to +149)	560 (38.6)	215 (14.8)	560 (38.6)	1120 (77.0)
-20 to +400 (-29 to +204)	515 (35.5)	195 (13.6)	515 (35.5)	1025 (70.9)

NOTE 1: These pressure ratings may be further derated by limitations through the Pressure Equipment Directive (2014/68/EU). Whenever body and topworks are mixed, the P vs. T ratings that should be applied are those which are lowest for the two materials.

Example: 600 lb. RF flanged **steel** body at 200 deg F maximum temp would have a preliminary inlet to 680 psig, but if fitted with a **ductile iron** topworks pressure rating is only 370 psig. Must derate both the inlet and outlet to 370 psig. (Note: Topworks pressure rating, same as NPT design outlet pressure rating for the selected topworks material and diaphragm type.)

NOTE 2: Maximum Design Pressure Rating for 2" Opt -41 limited by 0.065" wall thickness to 1200 psig.

300# Flanges are derated due to the bolting for these products.

**TABLE DAG-2
MAXIMUM PRESSURE DROP FOR
COMPOSITION SEATS**

Body Size		Max. Pressure Drop - psid (Bard)											
		Seat Material											
in	(DN)	POLYALL *						GF-TFE					
		Liquid *		Gas		Steam	Liquid *		Gas		Steam √		
1/2" – 1"	(15-25)	600	(41.3)	750	(51.7)	DNA		450	(31.0)	1000	(68.9)	150/125	(10.3/8.6)
1-1/4" – 1-1/2"	(32-40)	600	(41.3)	600	(41.3)	DNA		450	(31.0)	900	(62.0)	150/125	(10.3/8.6)
2"	(50)	600	(41.3)	600	(41.3)	DNA		450	(31.0)	750	(51.7)	150/125	(10.3/8.6)
3" – 4"	(80-100)	500	(34.4)	600	(41.3)	DNA		450	(31.0)	750	(51.7)	125	(8.6)
		V-TFE						CTFE					
1/2" – 1"	(15-25)	300	(20.7)	600	(41.3)	125	(8.6)	600	(41.3)	3000	(206.9)	DNA	
1-1/4" – 1-1/2"	(32-40)	300	(20.7)	600	(41.3)	125	(8.6)	600	(41.3)	3000	(206.9)	DNA	
2"	(50)	300	(20.7)	600	(41.3)	125	(8.6)	600	(41.3)	2000	(137.9)	DNA	
3" – 4"	(80-100)	300	(20.7)	450	(31.0)	125	(8.6)	500	(34.4)	1500	(103.4)	DNA	

* Only seat material to be applied in liquid "partially cavitating" service is PolyAll.
√ Steam Service: metal diaphragm/composition diaphragm.
N/A = Not Available
DNA = Do Not Apply

**TABLE DAG-3
MAXIMUM PRESSURE DROP FOR
DYNAMIC SEAL DESIGNS**

Body Size		Max. Pressure Drop - psid (Bard)																	
		Dynamic Seal Design																	
in	(DN)	"OR" – O-RING *						"CP" – TFE CAP						"CW" – TFE CAP w/WIPER					
		Liquid *		Gas *		Steam		Liquid		Gas		Steam		Liquid		Gas		Steam	
1/2" – 1"	(15-25)	600	(41.3)	750	(51.7)	DNA		600	(41.3)	600	(41.3)	DNA		450	(31.0)	600	(41.3)	DNA	
1-1/4" – 1-1/2"	(32-40)	600	(41.3)	750	(51.7)	DNA		600	(41.3)	600	(41.3)	DNA		450	(31.0)	600	(41.3)	DNA	
2"	(50)	600	(41.3)	750	(51.7)	DNA		600	(41.3)	600	(41.3)	DNA		450	(31.0)	600	(41.3)	DNA	
3" – 4"	(80-100)	600	(41.3)	750	(51.7)	DNA		600	(41.3)	600	(41.3)	DNA		450	(31.0)	600	(41.3)	DNA	
		"PR" – PISTON RING ASSY.						"PW" – PISTON RING ASSY. w/WIPER						"UC" – U-CUP					
1/2" – 1"	(15-25)	DNA		DNA		150/125	(10.3/8.6)	DNA		DNA		150/125	(10.3/8.6)	600	(41.3)	3000	(206.9)	DNA	
1-1/4" – 1-1/2"	(32-40)	DNA		DNA		150/125	(10.3/8.6)	DNA		DNA		150/125	(10.3/8.6)	600	(41.3)	3000	(206.9)	DNA	
2"	(50)	DNA		DNA		150/125	(10.3/8.6)	DNA		DNA		150/125	(10.3/8.6)	600	(41.3)	3000	(206.9)	DNA	
3" – 4"	(80-100)	DNA		DNA		125	(8.6)	DNA		DNA		125	(8.6)	600	(41.3)	3000	(206.9)	DNA	

* Only seat material to be applied in liquid "partially cavitating" or "flashing" service is PolyAll.
√ Steam Service: metal diaphragm/composition diaphragm.
N/A = Not Available DNA = Do Not Apply wo/ = without w/ = with

**TABLE DAG-4
MAXIMUM PRESSURE DROP FOR
BASIC TRIM MATERIAL**

Body Size		Max Pressure Drop - psid (Bard)							
		Basic Trim Material							
in	(DN)	"P" – 17-4PH SST		"S" – 316L SST		"M" – Monel		"T" – Hybrid *	
1/2" – 2"	(15-50)	3000	(206.9)	800	(55.1)	1500	(103.4)	3000	(206.9)
3" – 4"	(80-100)	3000	(206.9)	800	(55.1)	1500	(103.4)	3000	(206.9)

* 17-4PH SST plug & piston, Monel cage.

**TABLE DAG-5
TEMPERATURE LIMITS
FOR ELASTOMERIC MATERIALS**

Elastomer			T Maximum		T Minimum	
	ID	Description	°F	(°C)	°F	(°C)
	Seats	PolyAll	Proprietary Polyurethane Derivative	225°	(107°)	-60°
GF-TFE		Glass-filled Polytetrafluorethylene	425°	(218°)	-325°	(-198°)
V-TFE		Virgin TFE	400°	(205°)	-325°	(-198°)
CTFE		Chlorotrifluoroethylene TFE	300°	(148°)	-325°	(-198°)
FKM		Fluorocarbon Elastomer	400°	(205°)	0°	(-17°)
Diaphragms		3-Ply	3-Ply TFE/FKM/TFE	400°	(205°)	0°
	BC	Neoprene (Polychloroprene)	250°	(121°)	-65°	(-53°)
	EPR	Ethylene Propylene	300°	(148°)	-40°	(-40°)
	FK	Fluorosilicone	350°	(177°)	-65°	(-54°)
	FKM	Fluorocarbon Elastomer	400°	(205°)	0°	(-17°)
	NBR	Buna-N (Nitrile)	250°	(121°)	-70°	(-56°)
	FKM+TFE	Fluorocarbon Elastomer + TFE	400°	(205°)	0°	(-17°)
Static Seals	RTFE	Bronze-filled TFE	425°	(218°)	70°	(21°)
	V-TFE	Virgin TFE	400°	(205°)	-325°	(-198°)
	EPR	Ethylene Propylene	300°	(148°)	-40°	(-40°)
	FK	Fluorosilicone	350°	(177°)	-65°	(-54°)
	FKM	Fluorocarbon Elastomer	400°	(205°)	-20°	(-28°)
	NBR	Buna-N	212°	(100°)	-40°	(-40°)
	SST/TFE	301/302 SST U-cup / TFE	400°	(205°)	-325°	(-198°)
	HC/TFE	Hastelloy C U-cup / TFE	400°	(205°)	-325°	(-198°)
Dynamic Seals	"PR"	Piston Ring Assy, GF-TFE / SST	425°	(218°)	-40°	(-40°)
	"PW"	PRA* w/Wiper, GF-TFE / SST / GF-TFE	425°	(218°)	70°	(21°)
	"CW" – EPR/TFE	TFE Cap Seal, EPR O-ring, GF-TFE Wiper	300°	(148°)	-40°	(-40°)
	"CW" – NBR/TFE	TFE Cap Seal, NBR O-ring, GF-TFE Wiper	212°	(100°)	-40°	(-40°)
	"CW" – FK/TFE	TFE Cap Seal, FK O-ring, GF-TFE Wiper	350°	(177°)	-40°	(-40°)
	"CW" – FKM/TFE	TFE Cap Seal, FKM O-ring, GF-TFE Wiper	400°	(205°)	-20°	(-28°)
	"CP" – EPR/TFE	TFE Cap Seal, EPR O-ring	300°	(148°)	-40°	(-40°)
	"CP" – NBR/TFE	TFE Cap Seal, NBR O-ring	212°	(100°)	-40°	(-40°)
	"CP" – FK/TFE	TFE Cap Seal, FK O-ring	350°	(177°)	-10°	(-23°)
	"CP" – FKM/TFE	TFE Cap Seal, FKM O-ring	400°	(205°)	-20°	(-28°)
	SST/TFE	301/302 SST U-cup / TFE	400°	(205°)	-325°	(-198°)
	HC/TFE	Hastelloy C U-cup / TFE	400°	(205°)	-325°	(-198°)
	ELG/TFE	Elgiloy / TFE U-cup	400°	(205°)	-325°	(-198°)

* PRA - Piston Ring Assembly

Metal Diaphragm		T Maximum		T Minimum	
ID	Description	°F	(°C)	°F	(°C)
BE-CU	Beryllium Copper	400°	(205°)	-325°	(-198°)

ABBREVIATIONS			
FK = Fluorosilicone	NBR = Buna-N	PTFE = Polytetrafluoroethylene	PRA = GF-TFE/SST
FKM = Fluorocarbon Elastomer	RTFE = Brz-fill TFE	V-TFE = Virgin TFE	BC = Neoprene
EPR = Ethylene Propylene	GF-TFE = Glass-fill TFE	CTFE = Chlorotrifluoroethylene TFE	ELG = Elgiloy

**TABLE DAG-7
BACK PRESSURE MAXIMUM CAPACITY WITH PLUG WIDE-OPEN**

Body Size		Full Port Max Capacity		Full Port Max Capacity	
in	(DN)	Cv	Kv	Cv	Kv
1/2"	(15)	4.0	2.9	3.0	2.6
3/4"	(20)	8.0	5.9	3.0	2.6
1"	(25)	12.8	11.0	3.0	2.6
1-1/4"	(32)	23	20	5.1	4.4
1-1/2"	(40)	26	22	5.1	4.4
2"	(50)	51	44	10.2	8.8
3"	(80)	120	104	X	
4"	(100)	187	161		
Diaphragm		Composition		Metal	

NOTE: The above Cv factors may be used for sizing of safety relief valves or rupture discs.

**TABLE DAG-10
INBOARD LEAKAGE RATINGS *
Per ANSI/FCI 70-2**

Seat Material	Dynamic Seal	
	O-Ring	Dynamic Seals Except O-Ring
CTFE, GF-TFE, and V-TFE	IV	IV
PolyAll, FKM	VI	IV

*Inboard leak rates are the composite leakage of the seat leakage + dynamic seal leakage, considered as a single inboard leakage value.

**TABLE DAG-12
BACK PRESSURE RECOMMENDED VELOCITY LIMITS**

Application Fluid	Valve Type	Valve Size Range		Upstream Pipe		Valve Body Inlet (1-Phase)		Valve Body Outlet	Downstream Pipe	Units
		in	(DN)	Recommend	Max.	Recommend	Max.			
		Liquid	BPV	1/2"-4"	(15-100)	5-8	16			
6"	(150)			7-12	20	15	24			
8"-12"	(200-300)			9-14	24	-	-			
Gas	BPV	1/2"-1"	(15-25)	0.15	0.30	0.15	0.25	<1.00	<0.8	Mach #
		1-1/4"-2"	(32-50)	0.20	0.30	0.20	0.30			
		2-1/2"-6"	(65-150)	0.22	0.30	0.25	0.35			
Steam	BPV	1/2"-1"	(15-25)	0.10	0.30	0.20	0.30	<0.8	<0.65	Mach #
		1-1/4"-2"	(32-50)	0.12		0.22				
		2-1/2"-6"	(65-150)	0.15		0.25				
Steam	BPV	8"-12"	(200-300)	0.20		-	-			

NOTES:

- Liquids experiencing no 2-phase flow at valve outlet will have same valve body outlet velocity as inlet velocity.
- Liquids experiencing 2-phase flow at valve outlet should have average velocity less than 150-200 ft/sec.
- Liquids experiencing 2-phase flow at outlet pipe should have average velocity less than 20-50 ft/sec.
- If valve outlet exceeds recommended limits, then can use external sensing to reach maximum limits.
- On gas service, a pilot operated prv can work with a outlet Mach = 0.75.

TABLE DAG-14
RECOMMENDED INTERNAL MATERIALS
For P_{max}, Reference Individual Technical Bulletins

LIQUIDS				
LIQUIDS	Fluid	Tmax °F	Tmin °F	Metal Trim
	Industrial Water – Cold		180°	32°
Hot		225°	32°	PJ
DI, DM		225°	32°	PJ
		250°	32°	PL
Seawater		180°	-20°	MH
Fuel Oils – Diesel, #1, #2‡		180°	-40°	P6
Bunker C, #3 - #6‡		180°	-40°	P6
		400°	0°	PD
Jet Fuel JP3, JP4, JP5, JP6‡		400°	0°	PD
Kerosene‡		400°	0°	PD
Crude Oils –Sweet‡		225°	0°	PB
		400°	0°	PD
Sour‡		225°	0°	CF *
Heat Transfer Oils – Dowtherm, Therminol, Mobil-Therm, Silvatherm		400°	0°	PD
Misc. Oils – Lube Oil‡		180°	-40°	P6
Naptha‡		400°	0°	PD
Turbine Oil‡		225°	0°	PB
Edible Oils – Vegetable Oil‡		180°	-30°	PH
Animal Fats‡		180°	-30°	PH
Seed Oils‡		180°	-30°	PH
Inorganic Acids – Acetic - 5%		100°	0°	SL
Acetic - 30%		100°	0°	SL
Sulfuric - conc.		100°	0°	CF *
Sulfuric - dilute		100°	0°	CF *
Nitric - conc.		140°	0°	SL
Nitric - dilute		140°	0°	SL
Hydrofluoric (air free) - dilute, concentrate		100°	0°	CF *
Hydrobromic		140°	0°	CF *
Phosphoric - dilute, concentrate		150°	0°	SL
Misc. Liquids – Gasoline‡		150°	-40°	P6
Benzene (C ₆ H ₆)‡		150°	0°	SL
Chlorine (Cl ₂)		150°	0°	ML
Bromine (Br ₂)		150°	0°	CF *
Ammonia (NH ₃)		140°	0°	SL
Hydrogen Peroxide (H ₂ O ₂)		125°	0°	SL
Hydrogen Chloride (HCl)		125°	0°	ML
Hydrogen Bromide (HBr)		125°	0°	SL
Cane Sugar Liquor		180°	0°	PH

‡ In accordance with ASME B31.3 "Process Piping", do not use Ductile Iron Body for hydrocarbon or flammable service with inlet pressures greater than 150 psig (10.3 Barg) or temperatures greater than 300 deg F (149 deg C).
* CF = Consult Factory

GASES				
LIQUIDS	Fluid	Tmax °F	Tmin °F	Trim
	Atmospheric Gases	Atmospheric Gases – O ₂ (GOX)	225°	-60°
350°			-65°	M9
350°			-325°	TN
N ₂ (GN ₂), Air, Argon		180°	-60°	P2
		350°	-65°	P8
CO ₂ (dry)		180°	-40°	P6
CO ₂ (wet)	180°	-40°	P6	
Process Gases	Process Gases – Nat. Gas (Sweet)	180°	-65°	P9
	Nat. Gas (Sour)	180°	-40°	CF *
	LPG (propane)	180°	-40°	PH
	Ammonia	120°	-40°	CF *
	Hydrogen	180°	-325°	SN
	Helium	180°	-325°	SN
	Chlorine (dry)	200°	0°	ME
	Hydrogen Chloride (dry)	120°	-40°	SJ
	Hydrogen Bromide (dry)	120°	0°	PE
	Hydrogen Fluoride (dry)	120°	0°	PE
	Hydrogen Sulfide (dry)	140°	0°	CF *
	Hydrogen Sulfide (wet)	140°	0°	CF *
	Sulfur Dioxide (dry)	120°	0°	PE
STEAM	P1 ≤ 125 psig	350°	—	PG

DAG-14 SUPPLEMENT CHEMICAL RESISTANCE

General Statement: Statements located within this technical bulletin concerning suitability of fluids with TFE materials are general statements, and should not be construed as recommendations. Any statements of suitability are the result of a compilation of various sources of information based on experience, tests, and published technical literature. No guarantee or warranty is in anyway implied for a given particular service or application.

Additional Reference: For an inclusive listing covering a broader range of service application fluids, reference "Handbook of Corrosion Resistant Piping", P.A. Schweitzer, Industrial Press or "Compass Corrosion Guide", 2nd Edition, K.M. Pruett, Compass Publications. This publication will include information based on the following fluid variables:

1. Solution concentration
2. Pressure
3. Temperature

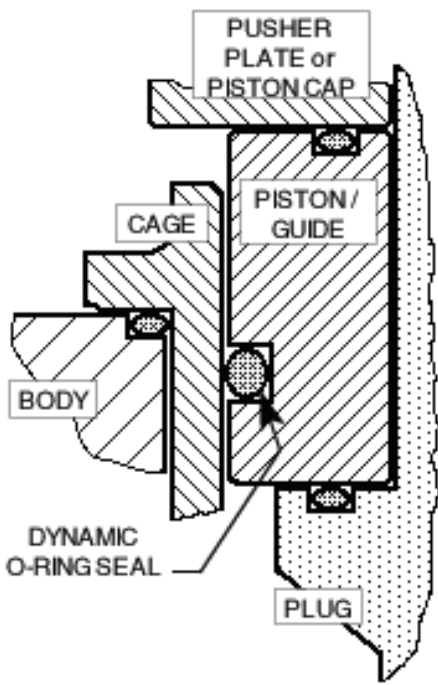

O-RING DYNAMIC SEAL

PRV, BPV

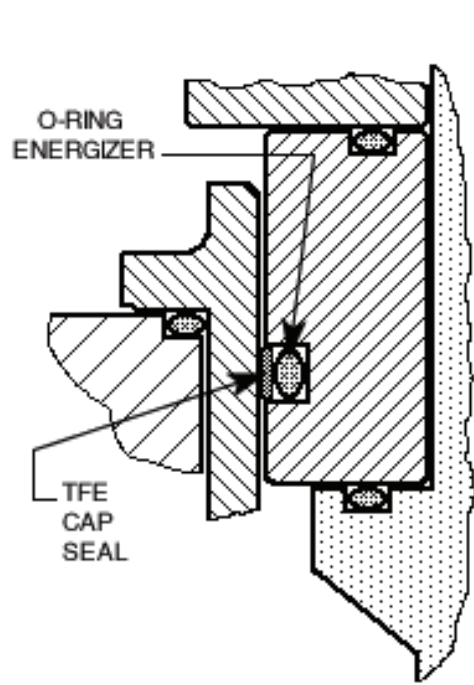

TFE CAP DYNAMIC SEAL

BPV

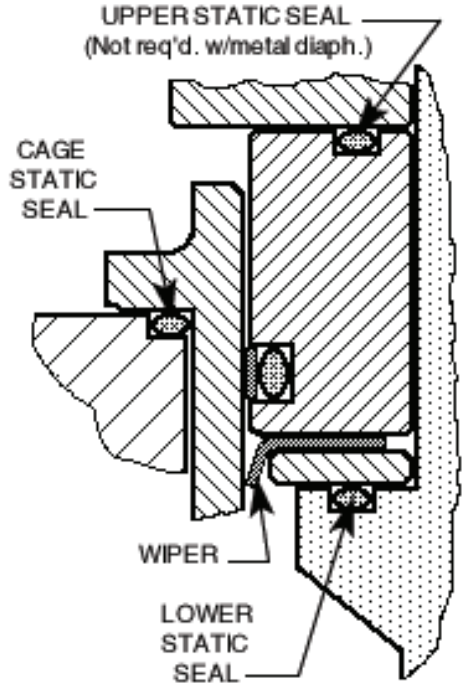

TFE CAP DYNAMIC SEAL + WIPER

PRV

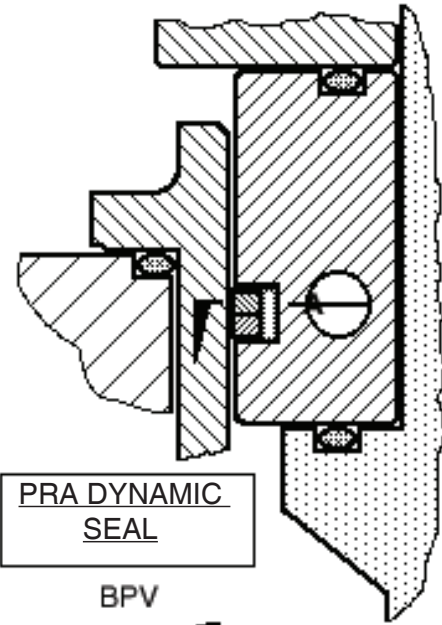

PRA DYNAMIC SEAL

BPV

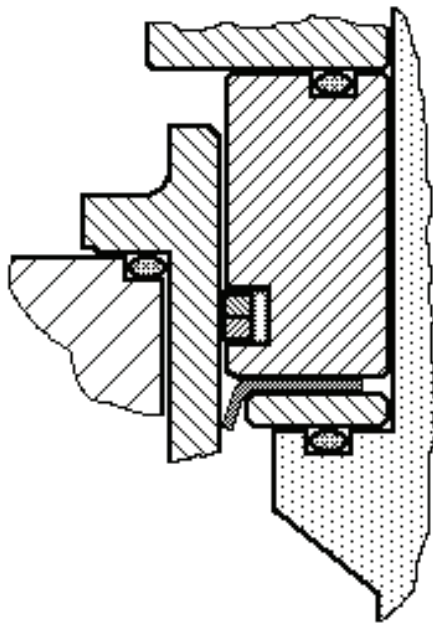

PRA DYNAMIC SEAL + WIPER

PRV

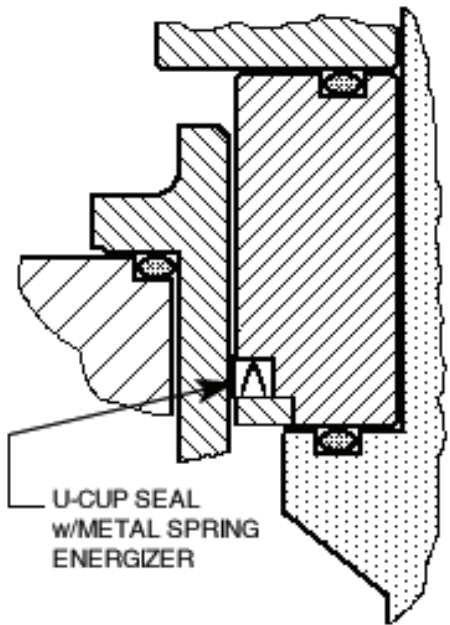

U-CUP DYNAMIC SEAL

PRV, BPV

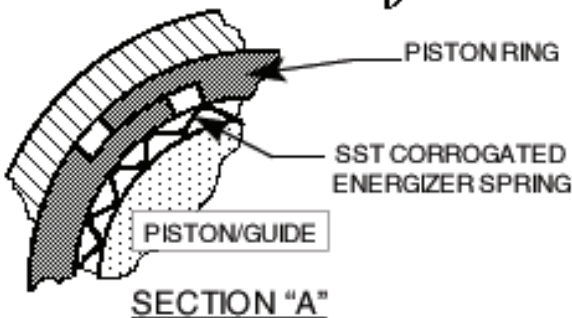

SECTION "A"

FIGURE DAG-F1
DYNAMIC & STATIC SEALS

FIGURE DAG-F2
Location of BODY / SPRING CHAMBER TAPS

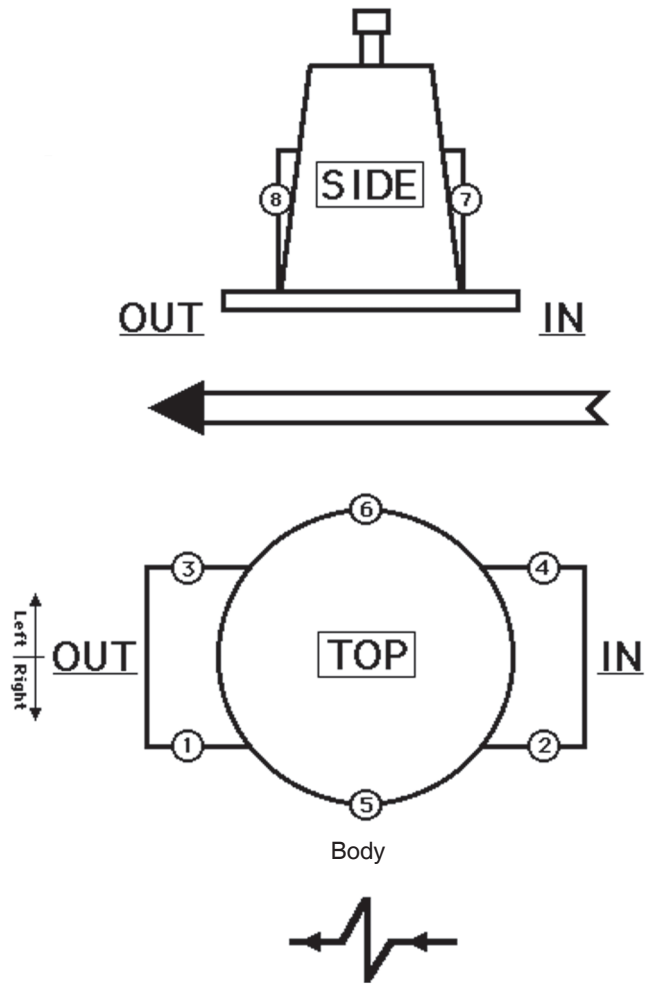

Flow To Open Direction

Location	Description	Opt. No.	NPT - Size	Body Mat'l.
1 & 2	Inlet & Outlet – Right	STD	1/4"	DI, CS & SST
1, 2 & 3	Inlet & Outlet – Right	STD	1/4"	BRZ
5	External Sensing – Right	STD	1/4"	ALL
1, 2, 3 & 4	Inlet & Outlet – Right Inlet & Outlet – Left	85	1/4"	ALL
5 & 6	Double External Sensing	85	1/4"	ALL

Location	Description	Opt. No.	NPT - Size	Sp. Ch. Mat'l.
7	Spring Ch. – Inlet Side	STD	1/4"	ALL
7 & 8	Double Spring Ch.	65A	1/4"	ALL
	Double Spring Ch.	65B	1/2"	CS ONLY
	Double Spring Ch.	65C	3/4"	
	Double Spring Ch.	65D	1"	

DIMENSION and WEIGHTS

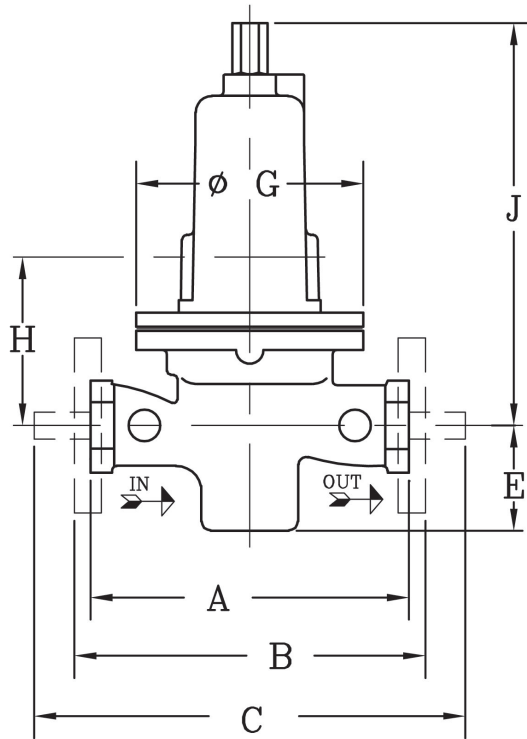

ENGLISH UNITS (in) (lbs)

DIMEN.	END CONN.	BODY MAT'L	BODY SIZE				
			1/2", 3/4 & 1"	1-1/4" & 1-1/2"	2"	3"	4"
A	NPT	DI, BRZ	6.00	9.88	9.88	-	-
		CS, SST	8.25	9.88	9.75	-	-
B	125# FF	DI	-	-	-	11.75	13.88
	250# RF	DI	-	-	-	12.50	14.50
	150# FF	BRZ **	9.63	11.50 ✓	11.50	11.75	13.88
	300# FF	BRZ **	9.63	11.50 ✓	11.50	12.15	14.50
	150# RF	CS, SST	10.75	12.38 ✓	10.00	11.75	13.88
	150# RF ‡	CS, SST	14.00	14.00 ✓	14.00	-	-
	300# RF	CS, SST	10.75	12.38 ✓	10.50	12.15	14.50
	300# RF ‡	CS, SST	14.00	14.00 ✓	14.00	-	-
	600# RF	CS, SST	10.75	12.38 ✓	11.25	13.25	15.50
	600# RF ‡	CS, SST	14.00	14.00 ✓	14.00	-	-
C	OPT-32 EXT NIPS	CS, SST	14.00	15.75	15.75	-	-
	OPT-41	SST	11.00	15.25	15.50	-	-
E	ALL	ALL	2.84	3.69	4.00	5.75	7.00
G	ALL	ALL	6.00	7.00	8.00	11.00	11.13
H	ALL	BRZ/DI †	5.00	5.44	5.80	8.50	8.50
	ALL	CS/SST †	6.10	6.36	6.91	10.50	10.50
J	ALL	ALL	10.13	12.63	13.00	23.00	23.50
WEIGHT	wo/ Flanges	ALL	23	33	39	-	-
	w/Flanges	ALL	28	43	52	175	190

METRIC UNITS (mm) (kg)

END CONN.	BODY MAT'L	BODY SIZE				
		DN15, DN20 & DN25	DN32 & DN40	DN50	DN80	DN100
NPT	DI, BRZ	152	251	251	-	-
	CS, SST	209	251	248	-	-
125# FF	DI	-	-	-	298	352
250# RF	DI	-	-	-	318	368
150# FF	BRZ **	246	292 ✓	292	298	352
300# FF	BRZ **	246	292 ✓	292	309	368
150# RF	CS, SST	273	314 ✓	254	298	352
150# RF ‡	CS, SST	356	356 ✓	356	-	-
300# RF	CS, SST	273	314 ✓	267	309	368
300# RF ‡	CS, SST	356	356 ✓	356	-	-
600# RF	CS, SST	273	314 ✓	286	336	394
600# RF ‡	CS, SST	356	356 ✓	356	-	-
OPT-32 EXT NIPS	CS, SST	356	400	400	-	-
OPT-41	SST	279	387	394	-	-
ALL	ALL	72	94	102	146	178
ALL	ALL	152	178	203	279	283
ALL	BRZ/DI †	127	138	147	216	216
ALL	CS/SST †	155	161	175	267	267
ALL	ALL	257	321	330	584	597
wo/ Flanges	ALL	11	16	18	-	-
w/Flanges	ALL	13	20	24	79	86

** Flanged BRZ bodies available in sizes 1", 1-1/2", 2", 3", & 4" ONLY.

† Spring Chamber material.

✓ Flange Connections not available for 1-1/4" body size.

‡ Opt-34: Special 14" F to F Flange dimensions, CS and SST body material only.

Consult Factory for dimensions of ISO DIN Flanged units. (PN16, PN25, PN40)

NOTES

The contents of this publication are presented for informational purposes only, and while every effort has been made to ensure their accuracy, they are not to be construed as warranties or guarantees, express or implied, regarding the products or services described herein or their use or applicability. We reserve the right to modify or improve the designs or specifications of such product at any time without notice. Cashco, Inc. does not assume responsibility for the selection, use or maintenance of any product. Responsibility for proper selection, use and maintenance of any Cashco, Inc. product remains solely with the purchaser.

MODEL DA8 PRODUCT CODER 02/07/20

An "X" in POS 12 followed by a 5-digit control number overrides remaining selections.

D8 POS 3 — POS 5 POS 6 & 7 **7** — POS 10 POS 11 POS 12 **0** POS 14 POS 15 POS 16 **0E**

POSITION 3 SIZES & DIAPHRAGM CONSTRUCTION			
Body Size		Diaphragm Support	
in	(DN)	STD CODE	OPT-81 CODE
1/2"	(15)	4	J
3/4"	(20)	5	K
1"	(25)	6	L
1-1/4"	(32)	7	M
1-1/2"	(40)	8	N
2"	(50)	9	P
3" ^	(80)	B	NA
4" ^	(100)	C	NA

^ Not available with metal diaphragms.
NA Not Available

POSITION 5 BODY & SPRING CHAMBER MATERIALS			
Materials	CODE	Materials	CODE
DI/DI	1	LCC/LCC * / **	6
BRZ/DI	2	LCC/SST *	8
BRZ/BRZ ††	B	SST/DI	7
CS/DI	4	SST/CS * √	9
CS/CS * √	5	SST/SST *	A

* For Opt-81 Select CS, LCC or SST Spring Chamber Material except in Canada, use SST. See Table 1. NOTE: (CS Spg Chmb Mat'l in Sizes 3"-4" not registered for shipment into Canada.)
**LCC Mat'l not available in 3" - 4".
†† Sizes 1/2" - 2"

POSITION 6 & 7 - DIAPHRAGM AND SEAT MATERIALS					
Trim Material	Seat	Diaphragm	O-ring/Seal		CODE
			Static	Dynamic	
17-4PH SST "P"	PA	BC	NBR	SST/TFE u-cup	P2
	CTFE	BC	NBR	SST/TFE u-cup	P3
	PA	NBR	NBR	SST/TFE u-cup	P6
	PA	FK	FK	SST/TFE u-cup	P7 ‡
	GF-TFE	FK	FK	SST/TFE u-cup	P8 ‡
	V-TFE	FK	FK	SST/TFE u-cup	P9 ‡
	PA	FKM	FKM	SST/TFE u-cup	PB
	GF-TFE	FKM	FKM	SST/TFE u-cup	PD
	V-TFE	FKM + TFE	SST/TFE u-cup	SST/TFE u-cup √	PE
	GF-TFE	3-ply	RTFE	SST/TFE u-cup \$	PF
	GF-TFE	3-ply	RTFE	PRA \$	PG
	PA	NBR	NBR	TFE+NBR CP	PH
	PA	EPR	EPR	TFE+EPR CP	PJ
	PA	FK	FK	TFE+FK CP	PK
	GF-TFE	FKM	FKM	TFE+FKM CP	PL
FKM	FKM	FKM	SST/TFE u-cup	PZ	
Monel "M"	PA	FK	FK	SST/TFE u-cup ††	M7 ‡
	V-TFE	FK	FK	SST/TFE u-cup	M9 ‡
	V-TFE	FKM-TFE	SST/TFE u-cup	SST/TFE u-cup √	ME
	PA	NBR	NBR	TFE+NBR CP	MH
	PA	EPR	EPR	TFE+EPR CP	MJ
	PA	FK	FK	TFE+FK CP	MK
	GF-TFE	FKM	FKM	TFE+FKM CP	ML
	FKM	FKM	FKM	SST/TFE u-cup	MZ
	PA	FK	FK	SST/TFE u-cup	S7 ‡
	V-TFE	FK	FK	SST/TFE u-cup	S9 ‡
316L SST "S"	PA	BE-CU *	SST/TFE u-cup	SST/TFE u-cup	SM
	V-TFE	BE-CU *	SST/TFE u-cup	SST/TFE u-cup	SN
	PA	NBR	NBR	TFE+NBR CP	SH
	PA	EPR	EPR	TFE+EPR CP	SJ
	PA	FK	FK	TFE+FK CP	SK
	GF-TFE	FKM	FKM	TFE+FKM CP	SL
	PA	FK	FK	SST/TFE u-cup ††	T7 ‡
	V-TFE	FK	FK	SST/TFE u-cup	T9 ‡
	PA	BE-CU *	SST/TFE u-cup	SST/TFE u-cup	TM
	V-TFE	BE-CU *	SST/TFE u-cup	SST/TFE u-cup	TN
17-4PH/ Monel/17-4PH "T"	PA	NBR	NBR	TFE+NBR CP	TH
	PA	EPR	EPR	TFE+EPR CP	TJ
	PA	FK	FK	TFE+FK CP	TK
	GF-TFE	FKM	FKM	TFE+FKM CP	TL

* 3" - 4" sizes are not available with metal diaphragm.
‡ For Low Ambient Temperatures (See DAG for Min. Temperatures)
†† For GOX service, PA seats allowed in BRZ Bodies w/ trim materials "M" or "T" only.
√ Sizes 3"-4" use V-TFE static seal.
\$ For Steam applications Max Press < 125 psig. Abbreviations defined on page 2

POSITION 10 - END CONNECTIONS / ASME								
Size	Material	Method	End Conn	CODE	End Conn	CODE	End Conn	CODE
1/2" - 2"	ALL	-	NPT	1	-	-	-	-
2-1/2" - 4"	DI	Integral	125#FF	2	250#RF	3	-	-
1", 1-1/2" - 4"	BRZ	Integral	150#FF	6	300#FF	7	-	-
1/2" - 3/4"	CS,SST	Opt-30	-	-	-	-	-	-
1" - 4"	CS-SST	Integral *	150#RF	4	300#RF	5	600# RF	8
1/2" - 2"	ALL	Opt-31	BSPT	P	-	-	-	-
1/2" - 2"	CS, SST	Opt-32	-	-	Extended Nipples	E	-	-
1/2" - 2" (14" F to F)	CS, SST	Opt-34 *	150#RF	V	300#RF	W	600#RF	Y
1/2" - 1", 1-1/2" - 2	SST	Opt-41	Non-High Purity Tube Ends	T	-	-	-	-

END CONNECTIONS FOR ISO DIN FLANGES						
DN	Material	Method	End Conn	CODE	End Conn	CODE
DN15-25, 40, 50	-	-	PN40 FF - will mate with PN16, 25 and 40	-	-	J
DN65-100	BRZ	Integral	PN16 FF	K	PN25 FF	L
DN15-25, 40, 50	CS, SST	Opt-30	PN40 RF - will mate with PN16, 25 and 40	-	-	D
DN80-100	CS, SST	Integral	PN16 RF	A	PN25 RF	C

* Flanges Not Available for 1-1/4" (DN32) size.
** 1" size w/ 600# RF CS, or SST has weld-on flanges Opt-30.

POSITION 11 - RANGE SPRINGS							
Body Size	Pressure Range		CODE	Body Size	Pressure Range		CODE
	psid	bard			psid	bard	
1/2" 3/4" 1" (DN15, 20 & 25)	1-5 ^	.07-.34	1	2" (DN50)	1-5 ^	.07-.34	1
	1-10 *	.07-.68	S		1-10 *	.07-.68	S
	5-20	.34-1.3	A		5-15	.34-1.0	M
	10-35	.68-2.4	B		10-30	.68-2.0	N
	20-80	1.3-5.5	C		15-50	1.0-3.4	P
	30-150	2.0-10.3	D		30-90	2.0-6.2	Q
1-1/4" 1-1/2" (DN3 & 40)	70-200	4.8-13.7	E	1-10	.07-.68	S	
	1-5 ^	.07-.34	1	3" & 4" (DN80 & 100)	5-20	.34-1.3	A
	1-10 *	.07-.68	S		10-40	.68-2.7	T
	5-20	.34-1.3	A		10-70	.68-4.8	J
	15-45	1.0-3.1	H		40-125	2.7-8.6	K
	10-70	.68-4.8	J		-	-	-
40-175	2.7-12.0	2	-		-	-	

^ Composition diaphragm construction ONLY
* Metal Diaphragm for P_{sp} ≥ 5 psid. (.34Bard)

POSITION 12 - SENSING FLOW DIRECTION	
Option	Flow To Open CODE
Internal	1
External	2
Large Internal	4
For Special Construction Contact Cashco for Special Code	X

*** For information on ATEX see pages 17 & 18 on the IOM.**

POSITION 14 - SPRING CHAMBER OPTIONS		
Description	Option	CODE
Std Flow-thru connections 1/4"	-65A	F
Flow-thru Spring Chamber, 1/2" NPT CS Material ONLY.	-65B	G
Flow-thru Spring Chamber, 3/4" NPT CS Material ONLY.	-65C	H
Flow-thru Spring Chamber, 1" NPT CS Material ONLY.	-65D	K

POSITION 15 - BODY OPTIONS		
Description	Option	CODE
No Option	-	0
Second "SET" of 1/4" (DN8) FNPT Pressure Taps & Plugs.	-85	T

POSITION 16 - CERTIFICATE OPTIONS		
Description	Option	CODE
No Option	-	0
SPECIAL CLEANING: Per Cashco Spec #S-1134. W/ properly selected mat'ls. Suitable for Oxygen Service. BRZ or SST body material.	-55	M
SPECIAL CLEANING: Per Cashco Spec #S-1542.	-56	N
SPECIAL CLEANING: Per Cashco Spec #S-1589 Cl ₂ Service.	-57	P

Алматы (7273)495-231
Ангарск (3955)60-70-56
Архангельск (8182)63-90-72
Астрахань (8512)99-46-04
Барнаул (3852)73-04-60
Белгород (4722)40-23-64
Благовещенск (4162)22-76-07
Брянск (4832)59-03-52
Владивосток (423)249-28-31
Владикавказ (8672)28-90-48
Владимир (4922)49-43-18
Волгоград (844)278-03-48
Вологда (8172)26-41-59
Воронеж (473)204-51-73
Екатеринбург (343)384-55-89

Иваново (4932)77-34-06
Ижевск (3412)26-03-58
Иркутск (395)279-98-46
Казань (843)206-01-48
Калининград (4012)72-03-81
Калуга (4842)92-23-67
Кемерово (3842)65-04-62
Киров (8332)68-02-04
Копонна (4966)23-41-49
Кострома (4942)77-07-48
Краснодар (861)203-40-90
Красноярск (391)204-63-61
Курск (4712)77-13-04
Курган (3522)50-90-47
Липецк (4742)52-20-81

Магнитогорск (3519)55-03-13
Москва (495)268-04-70
Мурманск (8152)59-64-93
Набережные Челны (8552)20-53-41
Нижний Новгород (831)429-08-12
Новокузнецк (3843)20-46-81
Ноябрьск (3496)41-32-12
Новосибирск (383)227-86-73
Омск (3812)21-46-40
Орел (4862)44-53-42
Оренбург (3532)37-68-04
Пенза (8412)22-31-16
Петрозаводск (8142)55-98-37
Псков (8112)59-10-37
Пермь (342)205-81-47

Ростов-на-Дону (863)308-18-15
Рязань (4912)46-61-64
Самара (846)206-03-16
Санкт-Петербург (812)309-46-40
Саратов (845)249-38-78
Севастополь (8692)22-31-93
Саранск (8342)22-96-24
Симферополь (3652)67-13-56
Смоленск (4812)29-41-54
Сочи (862)225-72-31
Ставрополь (8652)20-65-13
Сургут (3462)77-98-35
Сыктывкар (8212)25-95-17
Тамбов (4752)50-40-97
Тверь (4822)63-31-35

Тольятти (8482)63-91-07
Томск (3822)98-41-53
Тула (4872)33-79-87
Тюмень (3452)66-21-18
Ульяновск (8422)24-23-59
Улан-Удэ (3012)59-97-51
Уфа (347)229-48-12
Хабаровск (4212)92-98-04
Чебоксары (8352)28-53-07
Челябинск (351)202-03-61
Череповец (8202)49-02-64
Чита (3022)38-34-83
Якутск (4112)23-90-97
Ярославль (4852)69-52-93

Россия +7(495)268-04-70

Казахстан +7(7172)727-132

Киргизия +996(312)96-26-47

<https://cashco.nt-rt.ru/> || coc@nt-rt.ru