



MODEL DA6

DO-ALL SERIES VI BACK PRESSURE REGULATOR

OVERVIEW

The Model DA6 is a high performance, pressure loaded, back pressure regulator with top-guided piston-cylinder that provides high flow capacity and high pressure drop capability. Internal trim design allows the same basic unit to cover a broad range of pressure settings. Performance approaches that of competitive pilot-operated designs in the basic design. Applied primarily in clean gaseous service, but also can be applied as a liquid or steam valve. Truly a "DO-ALL" pressure regulator. Requires auxiliary pressure loading fluid.

FEATURES

- Versatile:** Four basic materials and multiple trim material combinations to select from.
- Tight Shutoff:** Multiple composition materials provide Classes II, IV or VI inboard leakage rates. Designed as a soft-seated valve.
- Capacity:** Highest in the industry. Allows smaller body sizes than competitors in a majority of applications.
- Pressure Drop:** One of highest in the industry when coupled with high flow capacity.
- Trim Design:** "DO-ALL" trim design provides *FTO* flow direction. Results in high *sensitivity* and *stability*. Internals are *cage*-contained within easily removable *quick change trim*.
- Rangeability:** Basic valve gives outstanding rangeability due to close tolerances, balanced trim, and a broad range of elastomeric diaphragms and soft seats. Can be as high as 1000:1.
- Heavy-Duty Guiding:** Heavy top guided to maintain stability and increased diaphragm life.
- Failure Position:** Fails open on loss of loading pressure.
Fails closed on loss of P₁ pressure with loading pressure yet applied.

APPLICATIONS

"DO-ALL" concept allows application of all types of *clean* fluids. Designed primarily as a gaseous service valve, can be applied in liquid service applications where excessive cavitation or flashing is absent. Excellent for atmospheric industrial gases – GN₂, GOX, Ar, He, H₂, CO₂ – as well as a natural gas regulator. Used as a utilities – air, oil, water, steam – regulator. Corrosive and non-corrosive chemical services – gas or liquid – are possible with broad materials range.

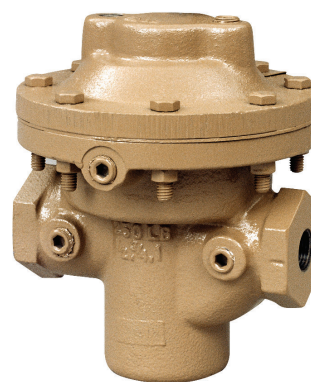

MODEL DA6



LINE SIZES AVAILABLE

1/2" (DN15), 3/4" (DN20), 1" (DN25),
1-1/4" (DN32), 1-1/2" (DN40), 2" (DN50),
2-1/2" (DN65), 3" (DN80), 4" (DN100)



END CONNECTIONS

NPT, FLANGED, BSPT, EXTENDED PIPE
NIPPLES, 14" FACE TO FACE, EXTENSION
TUBE ENDS



COMMON APPLICATIONS

CLEAN FLUIDS, ATMOSPHERIC
INDUSTRIAL GASES, NATURAL GAS,
AIR, OIL, WATER, STEAM, CORROSIVE &
NON-CORROSIVE CHEMICAL SERVICES



DESIGN PRESSURE

INLET: 2.0 WC" - 750 psig (51.7 Barg)
DROP: 5-750 psig (0.34-51.7 Barg)

Алматы (7273)495-231
Ангарск (3955)60-70-56
Архангельск (8182)63-90-72
Астрахань (8512)99-46-04
Барнаул (3852)73-04-60
Белгород (4722)40-23-64
Благовещенск (4162)22-76-07
Брянск (4832)59-03-52
Владивосток (423)249-28-31
Владикавказ (8672)28-90-48
Владимир (4922)49-43-18
Волгоград (844)278-03-48
Волгодонск (8172)26-41-59
Воронеж (473)204-51-73
Екатеринбург (343)384-55-89

Иваново (4932)77-34-06
Ижевск (3412)26-03-58
Иркутск (395)279-98-46
Казань (843)206-01-48
Калининград (4012)72-03-81
Калуга (4842)92-23-67
Кемерово (3842)65-04-62
Киров (8332)68-02-04
Коломна (4966)23-41-49
Кострома (4942)77-07-48
Краснодар (861)203-40-90
Красноярск (391)204-63-61
Курск (4712)77-13-04
Курган (3522)50-90-47
Липецк (4742)52-20-81

Магнитогорск (3519)55-03-13
Москва (495)268-04-70
Мурманск (8152)59-64-93
Набережные Челны (8552)20-53-41
Нижний Новгород (831)429-08-12
Новокузнецк (3943)20-46-81
Ноябрьск (3496)41-32-12
Новосибирск (383)227-86-73
Омск (3812)21-46-40
Орел (4862)44-53-42
Оренбург (3532)37-68-04
Пенза (8412)22-31-16
Петрозаводск (8142)55-98-37
Псков (8112)59-10-37
Пермь (342)205-81-47

Ростов-на-Дону (863)308-18-15
Рязань (4912)46-61-64
Самара (846)206-03-16
Санкт-Петербург (812)309-46-40
Саратов (845)249-38-78
Севастополь (8692)22-31-93
Саранск (8542)22-96-24
Симферополь (3652)67-13-56
Смоленск (4812)29-41-54
Сочи (862)225-72-31
Ставрополь (8652)20-65-13
Сургут (3462)77-98-35
Сыктывкар (8212)25-95-17
Тамбов (4752)50-40-97
Тверь (4822)63-31-35

Тольятти (8482)63-91-07
Томск (3822)98-41-53
Тула (4872)33-79-87
Тюмень (3452)66-21-18
Ульяновск (8422)24-23-59
Улан-Удэ (3012)59-97-51
Уфа (347)229-48-12
Хабаровск (4212)92-98-04
Чебоксары (8352)28-53-07
Челябинск (351)202-03-61
Череповец (8202)49-02-64
Чита (3022)38-34-83
Якутск (4112)23-90-97
Ярославль (4852)69-52-93

Россия +7(495)268-04-70

Казахстан +7(7172)727-132

Киргизия +996(312)96-26-47

STANDARD / GENERAL SPECIFICATIONS

Body / Cover Dome Materials

DI/DI	BRZ/BRZ	SST/DI
CS/DI	BRZ/DI	SST/CS
CS/CS	HC/CS *	SST/SST
	HC/SST *	

* Through 2" body size only.

DI = Ductile Iron CS = Carbon Steel BRZ = Bronze
SST = Stainless Steel HC = Hastelloy C

Body Sizes

1/2", 3/4", 1", 1-1/4", 1-1/2", 2", 2-1/2", 3", 4"
(DN15, 20, 25, 32, 40, 50, 65, 80, 100)

End Connections

Standard: Female NPT (screwed).
ASME Flanged: 125#, 150#, 250#, 300#, 600#;
DIN Flanged: PN16, PN25, PN40;
(Integral Flanged Body unless listed under Opt.-30)
Opt-31: British Standard Pipe Threads.
Opt-32: P.E. Extended Pipe Nipples.
Opt-34: 14" Face to Face Flange Dimension.
Opt-41 Extension Tube Ends.

Recommended Max. Useable Cv

Body Size		Diaphragm		Body Size		Diaphragm	
		Comp. Cv	Metal Cv			Comp. Cv	Metal Cv
in	(DN)			in	(DN)		
1/2"	(15)	2.7	2.1	2"	(50)	41	8.6
3/4"	(20)	5.4	2.1	2-1/2"	(65)	60	N/A
1"	(25)	10.2	2.5	3"	(80)	82	N/A
1-1/4"	(32)	15.7	4.3	4"	(100)	150	N/A
1-1/2"	(40)	20.8	4.3	–	–	–	–

See Table DAG-7 for Wide Open Cv Limits.

N/A = Not Available

METRIC CONVERSION FACTOR: $C_v / 1.16 = k_v$

Inlet Pressure Range

2.0" WC - 750 psig (51.7 Barg)
See Tables DAG-1A through -1H for design P vs. T limits for pressure containment. See Table 1 for maximum operating pressure to prevent diaphragm rupture.

Pressure Drop Limits

5–750 psid (.34-51.7 Bard)
Function of service fluid, base trim material, diaphragm and dynamic seal design. See Table 1 and Table DAG-2, DAG-3 and DAG-4.

Temperature Range

-425° to +400°F (-254° to +204° C)
Limited by body/cover dome/diaphragm material combinations, and by elastomeric seat, static seal, dynamic seal materials. See Tables DAG-1A through-1H & Table DAG-5.
Alternate "CS" Mat'l - Steel - ASTM A352 Gr. LCC - Minimum temperature -50 °F (-46 °C).

Inboard Leakage Rates

See Table DAG-10.

Optional Constructions

<u>Opt-30</u> : Weld-on Flanges	<u>Opt-81</u> : Full Diaphragm Support
<u>Opt-31</u> : BSP End Conns.	<u>Opt-85</u> : Extra Set Pressure Taps
<u>Opt-32</u> : Ext. Pipe Nipples	<u>Opt-96</u> : Bias Spring
<u>Opt-34</u> : 14" F to F Flange Dim.	
<u>Opt-40</u> : NACE Const.	
<u>Opt-41</u> : Ext. Tube Ends	
<u>Opt-55</u> : Oxygen Cleaned	
<u>Opt-56</u> : Special Cleaned	

ABBREVIATIONS

FK = Fluorosilicone	NBR = Buna-N	PTFE = Polytetrafluoroethylene
FKM = Fluorocarbon	RTFE = Brz-fill TFE	V-TFE = Virgin TFE
EPR = Ethylene Propylene	GF-TFE = Glass-fill TFE	CTFE = Chlorotrifluoroethylene
BC = Neoprene	PA = PolyAll	3-ply (PTFE+FKM+PTFE)

MATERIAL SPECIFICATIONS

Body

- DI – ASTM A395
- CS – ASTM A216, Grade WCB.
 Alternate ASTM A352 Gr. LCC
- BRZ – ASTM B62, Alloy 83600,
- SST – ASTM A351, Grade CF3M.
- HC – ASTM A494, Gr. CW-12 MW.

See DAG-1A through DAG-1H for material specs.

Cover Dome

- DI – ASTM A395
- CS – ASTM A216, Grade WCB.
 Alternate ASTM A352 Grade. LCC
- BRZ – ASTM B62, Alloy 83600,
- SST – ASTM A351, Grade CF3M

Metallic Trim *

17-4PH SST, 316LSST, Nickel-Copper Alloy (Monel †)
See Table 2

Diaphragm *

- Elastomeric – BC, EPR, FKM, FK, NBR, FKM+TFE,
 3-ply (PTFE+FKM+PTFE).
- Metallic – Be-Cu. (only 1/2" - 2" sizes)

Seat *

PolyAll, V-TFE, GF-TFE, CTFE, FKM

Static Seals (See Fig. DAG-F1)*

- RTFE, NBR, FKM, FK, EPR
- SST/TFE (1/2" - 2") (DN15 - 50)
- V-TFE (2-1/2" - 4") (DN65 - 100)

Dynamic Seals (See Fig. DAG-F1) *

- Type CP – TFE cap + NBR, FKM, FK, EPR o-ring seal.
- Type UC - V-TFE u-cup seal with 316L SST energizer;
 - V-TFE u-cup seal with Elgiloy energizer.
- Type PR - GF-TFE piston ring assembly seal with 17-7PH SST energizer.

Painting

Standard: All non-corrosion resistant portions to be painted with corrosion resistant epoxy paint per Cashco Spec #S-1606.

* See Product Coder for acceptable combinations
 † Monel™, and Inconel® are registered trade names:
 Monel™ is a mark owned by International Nickel Co.
 Inconel® is a mark owned by International Nickel Co.

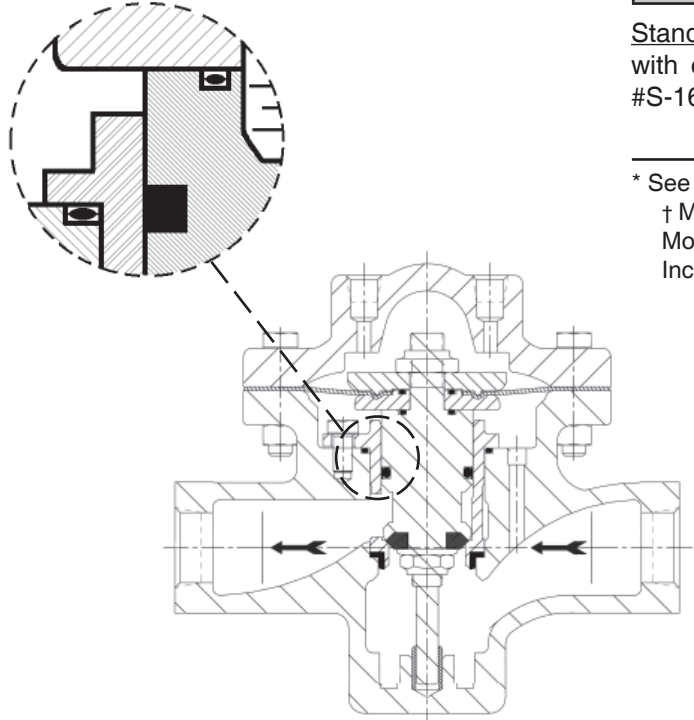

Reverse Flow Direction
Composition Diaphragm
FTO – Flow-to-Open
Balanced at Outlet

FIGURE 1 – Model DA6

OPTION SPECIFICATIONS

OPT-30: WELDED FLANGED CONNECTIONS. CS, SST or HC body materials only. 1/2"-2" (DN15-50) body sizes only (no 1-1/4" (DN32) size). Welded-on flange of same general chemistry as body.

Weld-On Flanges		
Sizes	Body Material	ASME Pressure Class
1/2" - 3/4"	CS, SST	150, 300, 600
1"	CS, SST	600
1" - 2"	HC	150, 300
Sizes	Body Material	ISO Pressure Class
DN15-50	CS, SST	PN40 RF
DN65-100	CS, SST	PN16, 25, 40 RF

NOTES: 1. The body P vs. T ratings are the limiting variables for flanged end connections, unless further restricted by ASME B16.5.

2. No post-weld stress relieving performed.

OPT-31: BSPT END CONNECTIONS. British Standard Pipe threads per ISO 7/1; used as an alternate to NPT ends. 1/2" – 2" (DN15-50) sizes only.

OPT-32: EXTENDED PIPE NIPPLES. Sch. 80 extension pipe nipples available for CS and SST bodies; for body sizes 1/2" – 2" (DN15-50) only.

OPT-34: SPECIAL 14" FACE TO FACE DIMENSION FOR FLANGED END CONNECTIONS. Sizes 1/2" - 1" & 1-1/2" only. See Opt.-30 for standard face to face dimension.

OPT-40: NACE CONSTRUCTION. Internal wetted portions meet NACE Std. MR0175; for application in sour gas/crude service. Exterior of unit to not be directly buried, insulated, or otherwise denied direct atmospheric exposure. CS/CS, LCC/LCC, LCC/SST, SST/CS, or SST/SST body/cover dome materials only. 316L SST trim materials only. ELG/TFE U-cup dynamic seals. Available in all end connections. All welded portions heat treated to stress relieve weldments.

OPT-41: EXTENDED TUBE END CONN. SST body material only. Body sizes 1/2"-1"(DN15-25), 1-1/2" & 2"(DN40-50) only. SST extension tubes are welded to body, ending in tube diameters with 0.065 inch (1.65 mm) wall thickness. NOT FOR HIGH PURITY REQUIREMENTS.

OPT-55: SPECIAL CLEANING - GOX. BRZ or SST body materials only. Cleaning, assembly and packaging per Cashco Spec. #S-1134, making unit suitable for Oxygen Service. **NOTE: Design Pressure Rating shall not exceed 375 psig (25.8 Barg) when body/topworks material is SST and process medium is oxygen.**

OPT-56: SPECIAL CLEANING. Cleaning per Cashco Spec. #S-1542 for all body & cover dome materials. Higher cleaning level than standard commercial cleaning. NOT suitable for Oxygen Service.

OPT-81: FULL DIAPHRAGM SUPPORT CONSTRUCTION. Incorporates top and bottom diaphragm support that allows reaching higher fluid pressures on the underside and top side of diaphragm. Sizes 1/2"-2" (DN15-50) only. See Table 1.

OPT-85: PRESSURE TAPS. Provides second set of inlet and outlet 1/4" (DN8) - FNPT taps with plugs (same basic material as body) on backside of body. Includes second external sensing port tap. See page 18 for details on tap location for both STD. and Opt -85. **NOTE:** Not available for HC body.

OPT-96: BIAS SPRING. On loss of P1 signal, plug/guide bearing strokes to full open position.

TECHNICAL SPECIFICATIONS

**TABLE 1
MAXIMUM DIAPHRAGM RATING***

NOTE: The below ratings may be further "derated" by limitations through the Pressure Equipment Directive (2014/68/EU).

Diaphragm Material	BODY SIZE 1/2"-2" (DN15-50)		BODY SIZE 2-1/2"-4" (DN65-100)
	STD DIAPHRAGM CONSTRUCTION	** OPT-81 FULL DIAPHRAGM SUPPORT	STD DIAPHRAGM CONSTRUCTION
BC, EPR	1250 (86.1)	1250 (86.1)	800 (55.1)
NBR	450 (31.0)	1250 (86.1)	300 (20.6)
FKM, FKM+TFE, FK	700 (48.2)	1250 (86.1)	550 (37.9)
3-ply (PTFE+FKM+PTFE) ***	125 (8.6)	125 (8.6)	125 (8.6)
METAL Be-Cu ****	1500 (103)	NA	NA

* Maximum pressure setting of pressure safety device - safety relief valve or rupture disc.
 ** Not available for DI/DI, BRZ/DI, BRZ/BRZ, CS/DI & SST/DI body/cover dome constructions.
 *** For Steam applications. NA = NOT AVAILABLE
 **** Metal diaphragm not available w/ Bronze Cover Dome or for sizes 2-1/2" - 4".

**TABLE 2
METALLIC TRIM MATERIAL COMBINATIONS**

PART	TRIM DESIGNATION			
	P	M	S	T
Plug / Guide Bearing	17-4 PH SST	Monel†	316L SST	17-4 PH SST
Cage	316L SST	Monel†	316L SST	Monel†
Body Bushing	17-4 PH SST	Monel†	Monel†	Monel†
Bias Spring Opt-96	302 SST	–	302 SST	–

† See Page 3 for registered trade name information.

DAG TECHNICAL APPENDIX INDEX

<u>TABLE</u>	<u>TITLE</u>	<u>PAGE</u>
DAG-1A	DI – Press vs Temp vs End Conn Ratings	7
DAG-1B	BRZ – Press vs Temp vs End Conn Ratings	8
DAG-1D	CS – Design Inlet/Outlet - DA6	9
DAG-1F	SST – Design Inlet/Outlet - DA6	9
DAG-1H	HC – Design Inlet/Outlet - DA6	10
DAG-2	Max Pressure Drop - Comp Seat	11
DAG-3	Max Pressure Drop - Dynamic Seal Design	11
DAG-4	Max Pressure Drop - Basic Trim Mat'ls	11
DAG-5	Temperature Limits – Elastomer Mat'ls	12
DAG-7	Back Pressure Max Capacity - Plug Wide Open	13
DAG-8	Pressure Loading or Pilot Systems Tubing & Fitting Maximum Containment Pressure Process or Auxiliary Fluids	13
DAG-10	Inboard Leakage Ratings	14
DAG-12	Back Press Recommended Velocity Limits	14
DAG-14	Recommended Internal Materials - Liquids	15
DAG-14	Recommended Internal Materials - Gases	15
DAG-14	Supplement - Chemical Resistance	16

<u>FIGURE</u>	<u>TITLE</u>	<u>PAGE</u>
DAG-F1	Dynamic/Static Seals	17
DAG-F2	Location of Body Taps	18

TABLE DAG-1A
DI – DUCTILE IRON
BODY / TOPWORKS MATERIAL SPECIFICATIONS

DESIGN PRESSURE vs. TEMPERATURE vs. END CONNECTION RATINGS
(To ASME B16.1 for Flanged and B16.4 for NPT Connections per Cast Iron Rating)

Material Specifications (Body / Topworks)		End Connection – Inlet & Outlet					
Description (Abbr.)	ASTM No.	Temperature °F	Working Pressure – psig				
			End Connection – Pressure Class				
			NPT	125# FF	250# RF		
DI/DI (Note 1)	A395/ A395	-20° to +150°	400	200	500		
		200°	370	190	460		
		225°	355	180	440		
		250°	340	175	415		
		300°	310	165	375		
		350°	300	150	335		
		400°	250	140	290		
		406°	250	140	290		
			400 WOG, 250 S	225 WOG, 125 S	400 WOG, 250 S		
				Working Pressure – Barg			
				End Connection – Pressure Class			
				NPT	125# FF	250# RF	
				-29° to +65°	27.6	13.8	34.5
				107	24.5	12.5	30.2
				120°	23.4	12.1	28.7
		150°	21.2	11.2	25.7		
		177°	19.2	10.6	23.8		
		204°	17.5	9.6	20.3		

NOTE 1: Whenever body and topworks materials are mixed, the P vs. T ratings that should be applied are those which are lowest of the two materials.

Example: CS body, DI topworks; NPT end connections, 200°F temperature.

Because the topworks is not “end flanged”, use the DI limits of “400 PSIG CWP 370/200F” from above to compare to CS limits from DAG-1C values. The DI limits are lower, so ratings from DAG-1A MUST be used as the limits.

NOTE 2: Unless stated otherwise, design pressure is Maximum Allowable Working Pressure (MAWP) for Inlet and Outlet.

**TABLE DAG-1B
BRZ – BRONZE
BODY / TOPWORKS MATERIAL SPECIFICATIONS**

**DESIGN PRESSURE vs. TEMPERATURE vs. END CONNECTION RATINGS
(Per ASME B16.24 for Flanged and B16.15 for NPT Connections)**

Material Specifications (Body / Topworks)		End Connection – Inlet & Outlet (Note 2)				
Description (Abbr.)	ASTM No.	Temperature °F	Working Pressure –psig			
			End Connection – Pressure Class			
			NPT	150# FF	300# FF	
BRZ/BRZ (Note 1)	B62, Alloy C83600/B62, Alloy C83600	-325° to +150° *	500	225	500	
		175°	390	220	480	
		200°	385	210	465	
		225°	375	205	445	
		250°	365	195	425	
		300°	335	180	390	
		350°	300	165	350	
		400°	250	150	315	
		406°	250	150	315	
		Temperature °C	Working Pressure – Barg			
			End Connection – Pressure Class			
				NPT	150# FF	300# FF
			-198° to +65° *	34.5	15.5	34.5
			107°	25.8	14.0	30.8
			120°	25.1	13.5	29.5
			150°	23.0	12.4	26.8
			177°	20.4	11.3	24.0
			204°	17.8	10.3	21.4

NOTE 1: Whenever body and topworks materials are mixed, the P vs. T ratings that should be applied are those which are lowest of the two materials.

Example: BRZ body, DI topworks; NPT end connections, ambient temperature.
Because the topworks is not “end flanged”, use the DI limits of “400 PSIG CWP 370/200F” from DAG-1A to compare to above DAG-1B values. The DI limits are lower, so ratings from DAG-1A MUST be used as the limits.

NOTE 2: Unless stated otherwise, design pressure is Maximum Allowable Working Pressure (MAWP) for Inlet and Outlet.

* See Minimum Temperature Ratings Table below.

**DESIGN PRESSURE RATING
AT MIN. TEMPERATURE**

Regulator Function	Material Specifications (Body / Topworks - Connections) Description (Abbr.)	Pressure at Min. Temperature
Back Pressure Relief	BRZ/BRZ	Inlet - 500 psig CWP to -325°F (-198°C)
		Outlet - 500 psig CWP to -325°F (-198°C)
	SST/SST - NPT, BSP, Ext. Nipples, Tube Ends and 600# Flgs	Inlet - 625 psig CWP to -425°F (-254°C)
		Outlet - 625 psig CWP to -425°F (-254°C)

Body Material Specifications

Cast Steel A216 Gr.WCB or Steel Weldment A216 Gr. WCB w/ forged flanges A105

Alternate Material: Cast Steel A352 Gr. LCC or Steel Weldment A352 Gr. LCC w/ forged flanges A350 Gr. LF6 Class 2

Topworks Material Specifications

Cast Steel A216 Gr. WCB

Alternate Material: Cast Steel A352 Gr. LCC

DESIGN PRESSURE vs. TEMPERATURE vs. END CONNECTION RATINGS

(Per ASME B16.5 and B16.34) See NOTE 1

TABLE DAG-1D DESIGN PRESSURE (BOTH INLET AND OUTLET) FOR DA6 in PSIG (BARG)				
CONSTRUCTION	END CONNECTIONS			
	STD DIAPHRAGM	ALL		Opt-81 (Full Support Diaph.) DA6
DESIGN TEMP. RANGE: Deg F (Deg C) **	NPT, BSP, 600#, EXTD NIPP	150#	300#	NPT, BSP. 600#, EXTD NIPP
-20 to +100 (-29 to +38)	750 (51.7)	285 (19.6)	740 (51.1)	1350 (93.0)
-20 to +200 (-29 to +93)	680 (47.1)	260 (17.9)	680 (47.1)	1350 (93.0)
-20 to +300 (-29 to +149)	655 (45.1)	230 (15.8)	655 (45.1)	1310 (90.3)
-20 to +400 (-29 to +204)	635 (43.6)	200 (13.7)	635 (43.8)	1265 (87.3)

** Alternate Mat'l: ASTM 352 Gr. LCC Min. Temperature -50 °F(-46°C).

Body Material Specifications

Cast Stainless Steel A351 Gr.CF3M or Stainless Steel Weldment A315 Gr. CF3M w/ forged flanges A182 Gr. F 316L

Topworks Material Specifications

Cast Stainless Steel A351 Gr.CF3M

DESIGN PRESSURE vs. TEMPERATURE vs END CONNECTION RATINGS

(Per ASME B16.5 and B16.34) See NOTE 1 using SST specifications; & NOTE 2

TABLE DAG-1F DESIGN PRESSURE (BOTH INLET AND OUTLET) FOR DA6 in PSIG (BARG)				
CONSTRUCTION *	END CONNECTIONS			
	STD DIAPHRAGM	ALL		Opt-81 (Full Support Diaph.) DA6
DESIGN TEMP. RANGE: Deg F (Deg C)	NPT, BSP, 600#, EXTD NIPP, TUBE	150#	300#	NPT, BSP. 600#, EXTD NIPP, TUBE
-425 to +100 (-254 to +38)	625 (43.0)	275 (19.0)	625 (43.0)	1125 (77.5)
-20 to +200 (-29 to +93)	620 (42.3)	235 (16.5)	620 (42.3)	1125 (77.5)
-20 to +300 (-29 to +149)	560 (38.6)	215 (14.8)	560 (38.6)	1120 (77.0)
-20 to +400 (-29 to +204)	515 (35.5)	195 (13.6)	515 (35.5)	1025 (70.9)

NOTE 1: These pressure ratings may be further derated by limitations through the Pressure Equipment Directive (2014/68/EU). Whenever body and topworks are mixed, the P vs. T ratings that should be applied are those which are lowest for the two materials.

Example: 600 lb. RF flanged **steel** body at 200 deg F maximum temp would have a preliminary inlet to 680 psig, but if fitted with a **ductile iron** topworks pressure rating is only 370 psig. Must derate both the inlet and outlet to 370 psig. (Note: Topworks pressure rating, same as NPT design outlet pressure rating for the selected topworks material and diaphragm type.)

NOTE 2: Maximum Design Pressure Rating for 2" Opt -41 limited by 0.065" wall thickness to 1200 psig.

300# Flanges are derated due to the bolting for these products.

Body Material Specifications

Cast Hastelloy A494 Gr.CW-12MW or Hastelloy Weldment A494 Gr. CW-12MW w/ forged flanges B462 Gr. N10276

Topworks Material Specifications

Cast Steel A216 Gr. WCB

DESIGN PRESSURE vs. TEMPERATURE vs END CONNECTION RATINGS

(Per ASME B16.5 and B16.34) See NOTE 1

TABLE DAG-1H			
DESIGN PRESSURE (BOTH INLET AND OUTLET)			
FOR DA6 in PSIG (BARG)			
CONSTRUCTION	END CONNECTIONS		
DESIGN TEMP. RANGE: Deg F (Deg C)	NPT, BSP	150#	300#
-325 to +100 (-198 to +38)	625 (43.0)	230 (15.9)	600 (41.4)
-20 to +200 (-29 to +93)	550 (38.2)	210 (14.7)	550 (38.2)
-20 to +300 (-29 to +149)	520 (35.9)	200 (13.7)	520 (35.9)
-20 to +400 (-29 to +204)	490 (33.8)	190 (12.9)	490 (33.8)

NOTE 1: These pressure ratings may be further derated by limitations through the Pressure Equipment Directive (2014/68/EU).

**TABLE DAG-2
MAXIMUM PRESSURE DROP FOR
COMPOSITION SEATS**

Body Size		Max. Pressure Drop - psid (Bard)											
		Seat Material											
in	(DN)	POLYALL *, FKM						GF-TFE					
		Liquid *		Gas		Steam	Liquid *		Gas		Steam √		
1/2" - 1"	(15-25)	600	(41.3)	750	(51.7)	DNA		450	(31.0)	1000	(68.9)	150/125	(10.3/8.6)
1-1/4" - 1-1/2"	(32-40)	600	(41.3)	600	(41.3)	DNA		450	(31.0)	900	(62.0)	150/125	(10.3/8.6)
2"	(50)	600	(41.3)	600	(41.3)	DNA		450	(31.0)	750	(51.7)	150/125	(10.3/8.6)
2-1/2" - 4"	(65-100)	500	(34.4)	600	(41.3)	DNA		450	(31.0)	750	(51.7)	125	(8.6)
		V-TFE					CTFE						
1/2" - 1"	(15-25)	300	(20.7)	600	(41.3)	125	(8.6)	600	(41.3)	3000	(206.9)	DNA	
1-1/4" - 1-1/2"	(32-40)	300	(20.7)	600	(41.3)	125	(8.6)	600	(41.3)	3000	(206.9)	DNA	
2"	(50)	300	(20.7)	600	(41.3)	125	(8.6)	600	(41.3)	2000	(137.9)	DNA	
2-1/2" - 4"	(65-100)	300	(20.7)	450	(31.0)	125	(8.6)	500	(34.4)	1500	(103.4)	DNA	

* Only seat material to be applied in liquid "partially cavitating" service is PolyAll.
 √ Steam Service: metal diaphragm/composition diaphragm.
 N/A = Not Available
 DNA = Do Not Apply

**TABLE DAG-3
MAXIMUM PRESSURE DROP FOR
DYNAMIC SEAL DESIGNS**

Body Size		Max. Pressure Drop - psid (Bard)																
		Dynamic Seal Design																
in	(DN)	"OR" - O-RING *					"CP" - TFE CAP					"CW" - TFE CAP w/WIPER						
		Liquid *		Gas *		Steam	Liquid		Gas		Steam	Liquid		Gas		Steam		
1/2" - 1"	(15-25)	600	(41.3)	750	(51.7)	DNA		600	(41.3)	600	(41.3)	DNA		450	(31.0)	600	(41.3)	DNA
1-1/4" - 1-1/2"	(32-40)	600	(41.3)	750	(51.7)	DNA		600	(41.3)	600	(41.3)	DNA		450	(31.0)	600	(41.3)	DNA
2"	(50)	600	(41.3)	750	(51.7)	DNA		600	(41.3)	600	(41.3)	DNA		450	(31.0)	600	(41.3)	DNA
2-1/2" - 4"	(65-100)	600	(41.3)	750	(51.7)	DNA		600	(41.3)	600	(41.3)	DNA		450	(31.0)	600	(41.3)	DNA
		"PR" - PISTON RING ASSY.					"PW" - PISTON RING ASSY. w/WIPER					"UC" - U-CUP						
1/2" - 1"	(15-25)	DNA		DNA		√	(10.3/8.6)	DNA		DNA		√	(10.3/8.6)	600	(41.3)	3000	(206.9)	DNA
1-1/4" - 1-1/2"	(32-40)	DNA		DNA		√	(10.3/8.6)	DNA		DNA		√	(10.3/8.6)	600	(41.3)	3000	(206.9)	DNA
2"	(50)	DNA		DNA		√	(10.3/8.6)	DNA		DNA		√	(10.3/8.6)	600	(41.3)	3000	(206.9)	DNA
2-1/2" - 4"	(65-100)	DNA		DNA		125	(8.6)	DNA		DNA		125	(8.6)	600	(41.3)	3000	(206.9)	DNA

* Only seat material to be applied in liquid "partially cavitating" or "flashing" service is PolyAll.
 √ Steam Service: metal diaphragm/composition diaphragm.
 N/A = Not Available DNA = Do Not Apply wo/ = without w/ = with

**TABLE DAG-4
MAXIMUM PRESSURE DROP FOR
BASIC TRIM MATERIAL**

Body Size		Max Pressure Drop - psid (Bard)							
		Basic Trim Material							
in	(DN)	"P" - 17-4PH SST		"S" - 316L SST		"M" - Monel		"T" - Hybrid *	
1/2" - 2"	(15-50)	3000	(206.9)	800	(55.1)	1500	(103.4)	3000	(206.9)
2-1/2" - 4"	(65-100)	3000	(206.9)	800	(55.1)	1500	(103.4)	3000	(206.9)

* 17-4PH SST plug & piston, Monel cage.

**TABLE DAG-5
TEMPERATURE LIMITS
FOR ELASTOMERIC MATERIALS**

Elastomer			T Maximum		T Minimum	
Seats	ID	Description	°F	(°C)	°F	(°C)
	Seats	PolyAll	Proprietary Polyurethane Derivative	225°	(107°)	-60°
GF-TFE		Glass-filled Polytetrafluorethylene	425°	(218°)	-325°	(-198°)
V-TFE		Virgin TFE	400°	(205°)	-325°	(-198°)
CTFE		Chlorotrifluoroethylene TFE	300°	(148°)	-325°	(-198°)
FKM		Fluorocarbon Elastomer	400°	(205°)	0°	(-17°)
Diaphragms	3-Ply	3-Ply TFE/FKM/TFE	400°	(205°)	0°	(-17°)
	BC	Neoprene (Polychloroprene)	250°	(121°)	-65°	(-53°)
	EPR	Ethylene Propylene	300°	(148°)	-40°	(-40°)
	FK	Fluorosilicone	350°	(177°)	-65°	(-54°)
	FKM	Fluorocarbon Elastomer	400°	(205°)	0°	(-17°)
	NBR	Buna-N (Nitrile)	250°	(121°)	-70°	(-56°)
	FKM+TFE	Fluorocarbon Elastomer + TFE	400°	(205°)	0°	(-17°)
Static Seals	RTFE	Bronze-filled TFE	425°	(218°)	70°	(21°)
	V-TFE	Virgin TFE	400°	(205°)	-325°	(-198°)
	EPR	Ethylene Propylene	300°	(148°)	-40°	(-40°)
	FK	Fluorosilicone	350°	(177°)	-65°	(-54°)
	FKM	Fluorocarbon Elastomer	400°	(205°)	-20°	(-28°)
	NBR	Buna-N	212°	(100°)	-40°	(-40°)
	SST/TFE	301/302 SST U-cup / TFE	400°	(205°)	-325°	(-198°)
	HC/TFE	Hastelloy C U-cup / TFE	400°	(205°)	-325°	(-198°)
Dynamic Seals	"PR"	Piston Ring Assy, GF-TFE / SST	425°	(218°)	-40°	(-40°)
	"PW"	PRA* w/Wiper, GF-TFE / SST / GF-TFE	425°	(218°)	70°	(21°)
	"CW" – EPR/TFE	TFE Cap Seal, EPR O-ring, GF-TFE Wiper	300°	(148°)	-40°	(-40°)
	"CW" – NBR/TFE	TFE Cap Seal, NBR O-ring, GF-TFE Wiper	212°	(100°)	-40°	(-40°)
	"CW" – FK/TFE	TFE Cap Seal, FK O-ring, GF-TFE Wiper	350°	(177°)	-40°	(-40°)
	"CW" – FKM/TFE	TFE Cap Seal, FKM O-ring, GF-TFE Wiper	400°	(205°)	-20°	(-28°)
	"CP" – EPR/TFE	TFE Cap Seal, EPR O-ring	300°	(148°)	-40°	(-40°)
	"CP" – NBR/TFE	TFE Cap Seal, NBR O-ring	212°	(100°)	-40°	(-40°)
	"CP" – FK/TFE	TFE Cap Seal, FK O-ring	350°	(177°)	-10°	(-23°)
	"CP" – FKM/TFE	TFE Cap Seal, FKM O-ring	400°	(205°)	-20°	(-28°)
	SST/TFE	301/302 SST U-cup / TFE	400°	(205°)	-325°	(-198°)
	HC/TFE	Hastelloy C U-cup / TFE	400°	(205°)	-325°	(-198°)
	ELG/TFE	Elgiloy / TFE U-cup	400°	(205°)	-325°	(-198°)

* PRA - Piston Ring Assembly

Metal Diaphragm		T Maximum		T Minimum	
ID	Description	°F	(°C)	°F	(°C)
BE-CU	Beryllium Copper	400°	(205°)	-325°	(-198°)

ABBREVIATIONS			
FK = Fluorosilicone	NBR = Buna-N	PTFE = Polytetrafluoroethylene	PRA = GF-TFE/SST
FKM = Fluorocarbon Elastomer	RTFE = Brz-fill TFE	V-TFE = Virgin TFE	BC = Neoprene
EPR = Ethylene Propylene	GF-TFE = Glass-fill TFE	CTFE = Chlorotrifluoroethylene TFE	ELG = Elgiloy

**TABLE DAG-7
BACK PRESSURE MAXIMUM CAPACITY WITH PLUG WIDE-OPEN**

Body Size		Full Port Max Capacity		Full Port Max Capacity	
in	(DN)	Cv	Kv	Cv	Kv
1/2"	(15)	4.0	3.4	3.0	2.6
3/4"	(20)	8.0	6.9	3.0	2.6
1"	(25)	12.8	11.0	3.0	2.6
1-1/4"	(32)	23	20	5.1	4.4
1-1/2"	(40)	26	22	5.1	4.4
2"	(50)	51	44	10.2	8.8
2-1/2"	(65)	77	66	X	
3"	(80)	120	104		
4"	(100)	187	161		
Diaphragm		Composition		Metal	
NOTE: The above Cv factors may be used for sizing of safety relief valves or rupture discs.					

**TABLE DAG-8
PRESSURE LOADING OR PILOT SYSTEMS
MAXIMUM CONTAINMENT PRESSURE PROCESS OR AUXILIARY FLUIDS**

TUBE	FITTINGS	PRESSURE		vs.	TEMPERATURE	
		psig	(Barg)		°F	(°C)
CU*	BR	1400	(96.5)		-325 to +100	(-198 to +37.7)
		1140	(78.6)		200	(93.3)
		1100	(75.8)		300	(148.8)
		700	(48.2)		400	(204.4)
		3300	(227)		-325 to +400	(-198 to +204.4)
SST^	SST	3300	(227)		-325 to +400	(-198 to +204.4)

*1/4" O.D. X 0.030" Wall Thickness
^1/4" O.D. X 0.028" Wall Thickness

Application Notes:

1. For CU+BR System - if P1 pressure exceeds above limits, tubing & fittings materials as well as other system components MUST be switched over to SST materials.
2. Consult Factory for T1<0° F.
3. Use Heat Exchange "coils" when loading fluid (process, auxiliary) T1>140°F
4. Use Heat Exchange "coils" when T1<0°F
5. Other components of a given loading or piloting system may have lower limits of pressure or temperature than the tubing & fittings.

**TABLE DAG-10
INBOARD LEAKAGE RATINGS *
Per ANSI/FCI 70-2**

Seat Material	Dynamic Seal	
	O-Ring	Dynamic Seals Except O-Ring
CTFE, GF-TFE, and V-TFE	IV	IV
PolyAll, FKM	VI	IV
*Inboard leak rates are the composite leakage of the seat leakage + dynamic seal leakage, considered as a single inboard leakage value.		

**TABLE DAG-12
BACK PRESSURE RECOMMENDED VELOCITY LIMITS**

Application Fluid	Valve		Upstream Pipe		Valve Body			Downstream Pipe	Units	
	Type	Size Range			Inlet (1-Phase)		Outlet			
		in	(DN)	Recommend	Max.	Recommend				Max.
Liquid	BPV	1/2"-4"	(15-100)	5-8	16	15	20	See Notes 1 & 2 Below	See Notes 3 & 4 Below	Ft/Sec
		6"	(150)	7-12	20	15	24			
	BPV	8"-12"	(200-300)	9-14	24	-	-			
Gas	BPV	1/2"-1"	(15-25)	0.15	0.30	0.15	0.25	<1.00	<0.8	Mach #
		1-1/4"-2"	(32-50)	0.20	0.30	0.20	0.30			
	BPV	2-1/2"-6"	(65-150)	0.22	0.30	0.25	0.35			
Steam	BPV	1/2"-1"	(15-25)	0.10	0.30	0.20	0.30	<0.8	<0.65	Mach #
		1-1/4"-2"	(32-50)	0.12		0.22				
	BPV	2-1/2"-6"	(65-150)	0.15		0.25				
Steam	BPV	8"-12"	(200-300)	0.20		-	-			

NOTES:

- Liquids experiencing no 2-phase flow at valve outlet will have same valve body outlet velocity as inlet velocity.
- Liquids experiencing 2-phase flow at valve outlet should have average velocity less than 150-200 ft/sec.
- Liquids experiencing 2-phase flow at outlet pipe should have average velocity less than 20-50 ft/sec.
- If valve outlet exceeds recommended limits, then can use external sensing to reach maximum limits.
- On gas service, a pilot operated prv can work with a outlet Mach = 0.75.

TABLE DAG-14
RECOMMENDED INTERNAL MATERIALS
For P_{max}' Reference Individual Technical Bulletins

LIQUIDS					
LIQUIDS	Fluid	Tmax °F	Tmin °F	Metal Trim	
	LIQUIDS	Industrial Water – Cold	180°	32°	P2
Hot		225°	32°	PJ	
DI, DM		225°	32°	PJ	
		250°	32°	PL	
Seawater		180°	-20°	CF *	
Fuel Oils – Diesel, #1, #2‡		180°	-40°	P6	
Bunker C, #3 - #6‡		180°	-40°	P6	
		400°	0°	PD	
Jet Fuel JP3, JP4, JP5, JP6‡		400°	0°	PD	
Kerosene‡		400°	0°	PD	
Crude Oils – Sweet‡		225°	0°	PB	
		400°	0°	PD	
Sour‡		225°	0°	NS	
Heat Transfer Oils – Dowtherm, Therminol, Mobil-Therm, Silvatherm		400°	0°	PD	
Misc. Oils – Lube Oil‡		180°	-40°	P6	
Naptha‡	400°	0°	PD		
Turbine Oil‡	225°	0°	PB		
LIQUIDS	Edible Oils – Vegetable Oil‡	180°	-30°	PH	
	Animal Fats‡	180°	-30°	PH	
	Seed Oils‡	180°	-30°	PH	
	Inorganic Acids – Acetic - 5%	100°	0°	CF *	
	Acetic - 30%	100°	0°	CF *	
	Sulfuric - conc.	100°	0°	CF *	
	Sulfuric - dilute	100°	0°	CF *	
	Nitric - conc.	140°	0°	CF *	
	Nitric - dilute	140°	0°	CF *	
	Hydrofluoric (air free) - dilute, concentrate	100°	0°	CF *	
	Hydrobromic	140°	0°	CF *	
	Phosphoric - dilute, concentrate	150°	0°	CF *	
	Misc. Liquids – Gasoline‡	150°	-40°	P6	
	LIQUIDS	Benzene (C ₆ H ₆)‡	150°	0°	CF *
		Chlorine (Cl ₂)	150°	0°	CF *
Bromine (Br ₂)		150°	0°	CF *	
Ammonia (NH ₃)		140°	0°	CF *	
Hydrogen Peroxide (H ₂ O ₂)		125°	0°	CF *	
Hydrogen Chloride (HCl)		125°	0°	cf *	
Hydrogen Bromide (HBr)		125°	0°	CF *	
Cane Sugar Liquor		180°	0°	PH	

‡ In accordance with ASME B31.3 "Process Piping", do not use Ductile Iron Body for hydrocarbon or flammable service with inlet pressures greater than 150 psig (10.3 Barg) or temperatures greater than 300 deg F (149 deg C).
 * CF = Consult Factory

GASES				
GASES	Fluid	Tmax °F	Tmin °F	Trim
	Atmospheric Gases	Atmospheric Gases – O₂ (GOX)	225°	-60°
350°			-65°	M9
350°			-325°	TN
N ₂ (GN ₂), Air, Argon		180°	-60°	P2
		350°	-65°	P8
CO ₂ (dry)		180°	-40°	P6
CO ₂ (wet)	180°	-40°	P6	
Process Gases	Process Gases – Nat. Gas (Sweet)	180°	-65°	P9
	Nat. Gas (Sour)	180°	-40°	NR
	LPG (propane)	180°	-40°	PH
	Ammonia	120°	-40°	CF *
	Hydrogen	180°	-325°	SN
	Helium	180°	-325°	SN
	Chlorine (dry)	200°	0°	ME
	Hydrogen Chloride (dry)	120°	-40°	CF *
	Hydrogen Bromide (dry)	120°	0°	PE
	Hydrogen Fluoride (dry)	120°	0°	PE
	Hydrogen Sulfide (dry)	140°	0°	NS
	Hydrogen Sulfide (wet)	140°	0°	NS
	Sulfur Dioxide (dry)	120°	0°	PE
	STEAM	P1 ≤ 125 psig	350°	—

DAG-14 SUPPLEMENT CHEMICAL RESISTANCE

General Statement: Statements located within this technical bulletin concerning suitability of fluids with TFE materials are general statements, and should not be construed as recommendations. Any statements of suitability are the result of a compilation of various sources of information based on experience, tests, and published technical literature. No guarantee or warranty is in anyway implied for a given particular service or application.

Additional Reference: For an inclusive listing covering a broader range of service application fluids, reference "Handbook of Corrosion Resistant Piping", P.A. Schweitzer, Industrial Press or "Compass Corrosion Guide", 2nd Edition, K.M. Pruett, Compass Publications. This publication will include information based on the following fluid variables:

1. Solution concentration
2. Pressure
3. Temperature

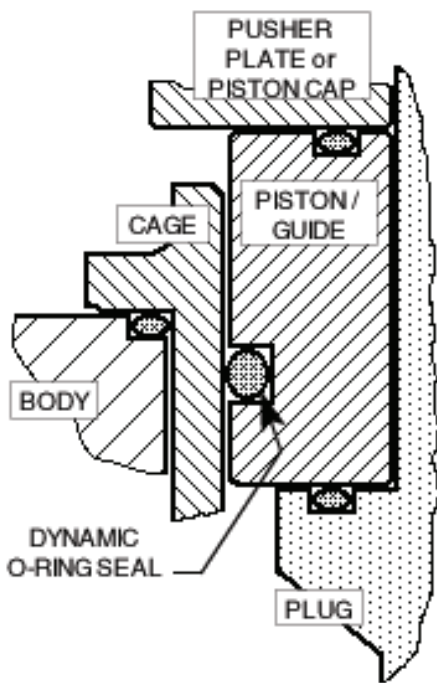

O-RING DYNAMIC SEAL

PRV, BPV

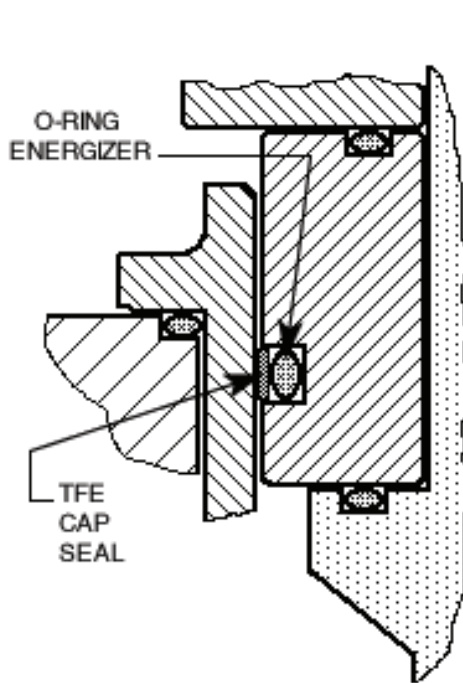

TFE CAP DYNAMIC SEAL

BPV

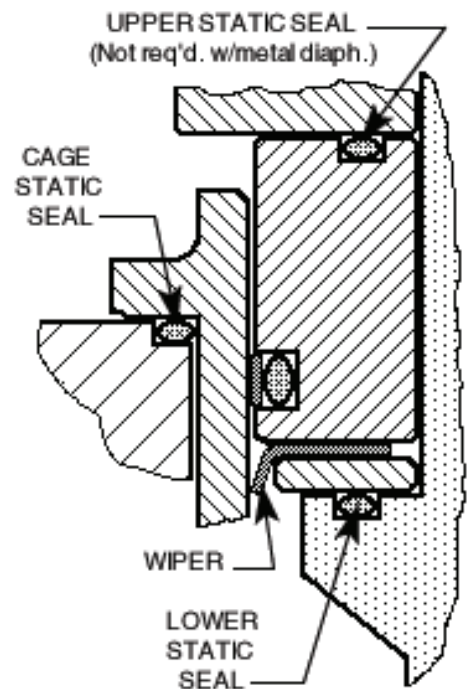

TFE CAP DYNAMIC SEAL + WIPER

PRV

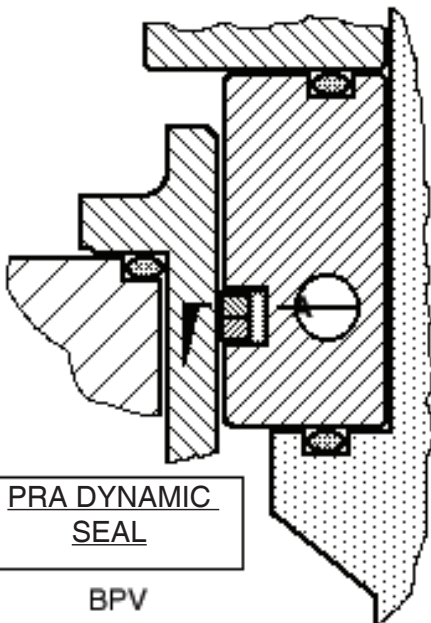

PRA DYNAMIC SEAL

BPV

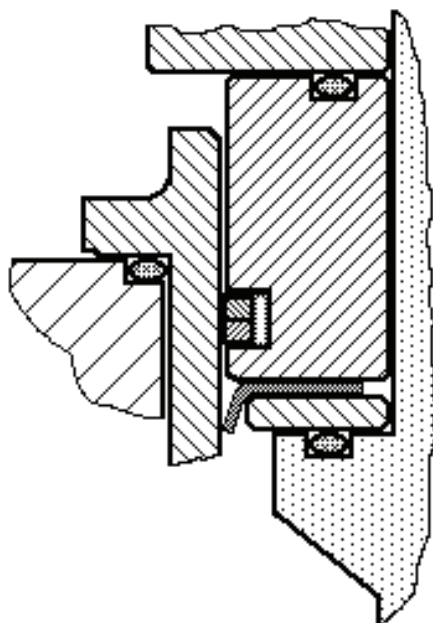

PRA DYNAMIC SEAL + WIPER

PRV

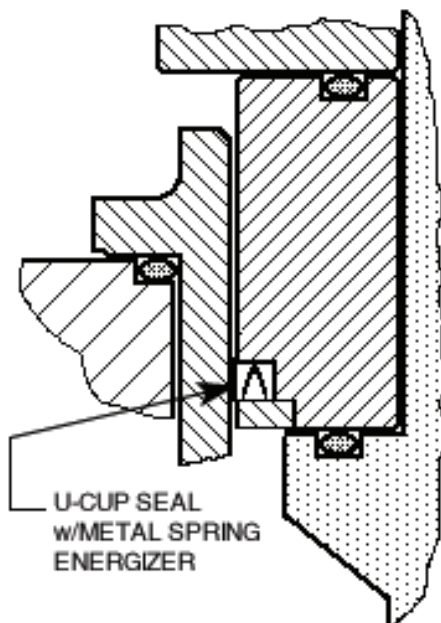

U-CUP DYNAMIC SEAL

PRV, BPV

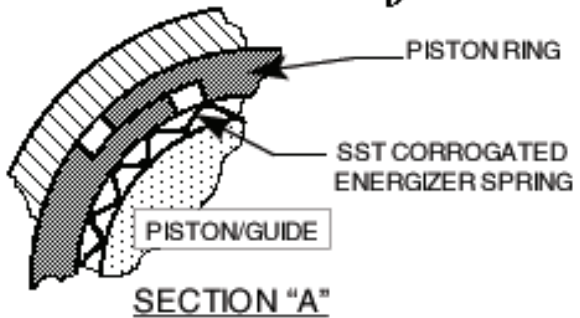

**FIGURE DAG-F1
DYNAMIC & STATIC SEALS**

FIGURE DAG-F2
Location of BODY TAPS

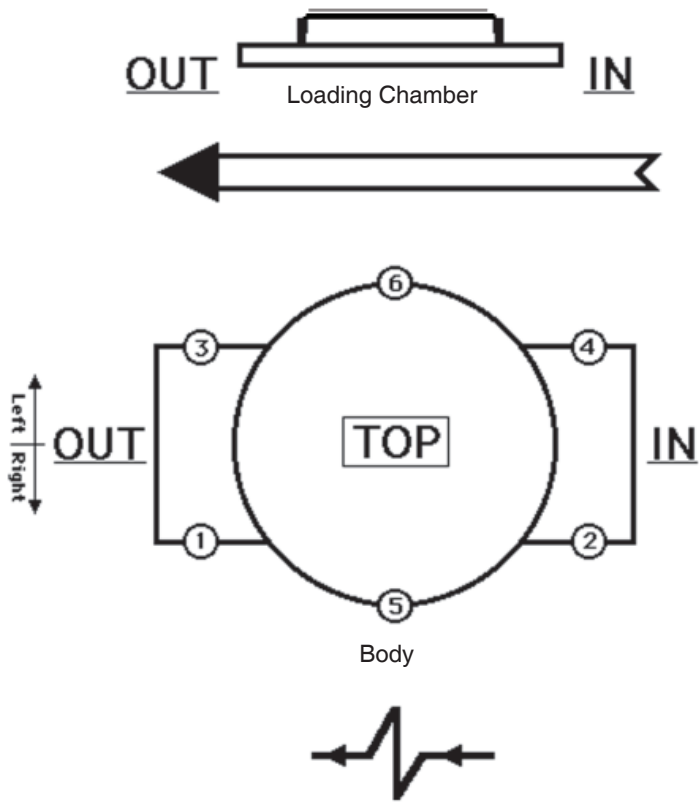

Flow To Open Direction

Location	Description	Opt. No.	NPT - Size	Body Mat'l.
1 & 2	Inlet & Outlet – Right	STD	1/4"	DI, CS & SST
1, 2 & 3	Inlet & Outlet – Right	STD	1/4"	BRZ
5	External Sensing – Right	STD	1/4"	DI, BRZ, CS & SST
1, 2, 3 & 4	Inlet & Outlet – Right Inlet & Outlet – Left	85	1/4"	DI, BRZ, CS & SST
5 & 6	Double External Sensing	85	1/4"	DI, BRZ, CS & SST

DIMENSION and WEIGHTS

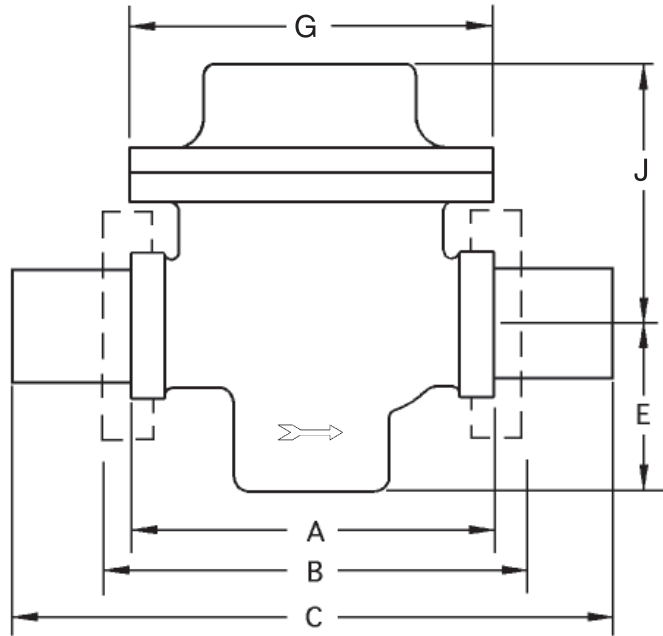

ENGLISH UNITS (in) (lbs)

DIMEN.	END CONN.	BODY MAT'L	BODY SIZE					
			1/2", 3/4 & 1"	1-1/4" & 1-1/2"	2"	2-1/2"	3"	4"
A	NPT	DI, BRZ	6.00	9.88	9.88	-	-	-
		CS, SST, HC	8.25	9.88	9.75	-	-	-
B	125# FF	DI	-	-	-	10.88	11.75	13.88
	250# RF	DI	-	-	-	11.50	12.50	14.50
	150# FF	BRZ **	9.63	11.50 √	11.50	10.88	11.75	13.88
	300# FF	BRZ **	9.63	11.50 √	11.50	11.50	12.15	14.50
	150# RF	CS, SST	10.75	12.38 √	10.00	10.88	11.75	13.88
		HC*			13.75	-	-	-
	150# RF ‡	CS, SST	14.00	14.00 √	14.00	-	-	-
	300# RF	CS, SST	10.75	12.38 √	10.50	11.50	12.50	14.50
		HC*			14.25	-	-	-
	300# RF ‡	CS, SST	14.00	14.00 √	14.00	-	-	-
600# RF	CS, SST	10.75	12.38 √	11.25	12.25	13.25	15.50	
600# RF ‡	CS, SST	14.00	14.00 √	14.00	-	-	-	
C	OPT-32 EXT NIPS	CS, SST	14.00	15.75	15.75	-	-	-
	OPT-41	SST	11.00	15.25	15.50	-	-	-
E	ALL	ALL	2.84	3.69	4.00	5.25	5.75	7.00
J	ALL	ALL	5.19	5.56	6.56	9.00	9.50	10.00
G	ALL	ALL	6.00	7.00	8.00	10.00	11.00	11.13
WEIGHT	wo/ Flanges	ALL	23	32	48	-	-	-
	w/ Flanges	ALL	28	42	61	90	155	164

METRIC UNITS (mm) (kg)

END CONN.	BODY SIZE					
	DN15, DN20 & DN25	DN32 & DN40	DN50	DN65	DN80	DN100
NPT	152	251	251	-	-	-
	209	251	248	-	-	-
125# FF	-	-	-	276	298	352
250# RF	-	-	-	292	318	368
150# FF	245	292 √	292	276	298	352
300# FF	245	292 √	292	292	309	368
150# RF	273	314 √	254	276	298	352
			349	-	-	-
150# RF ‡	356	356 √	356	-	-	-
300# RF	273	314 √	267	292	318	368
			362	-	-	-
300# RF ‡	356	356 √	356	-	-	-
600# RF	273	314 √	286	311	336	394
600# RF ‡	356	356 √	356	-	-	-
OPT-32 EXT NIPS	356	400	400	-	-	-
OPT-41	279	387	394	-	-	-
ALL	72	94	102	133	146	178
ALL	132	141	167	229	241	254
ALL	152	178	203	254	279	283
wo/ Flanges	10	14	22	-	-	-
w/ Flanges	12	19	28	41	70	74

* HC body material available in sizes 1", 1-1/2", & 2" ONLY.
 ** Flanged BRZ bodies available in sizes 1", 1-1/2", 2", 2-1/2", 3", & 4" ONLY.
 √ Flange Connection not available for 1-1/4" size.
 ‡ Opt-34: Special 14" F to F Flange dimensions, CS and SST body material only.
 Consult Factory for dimensions of ISO DIN Flanged units. (PN16, PN25, PN40)

The contents of this publication are presented for informational purposes only, and while every effort has been made to ensure their accuracy, they are not to be construed as warranties or guarantees, express or implied, regarding the products or services described herein or their use or applicability. We reserve the right to modify or improve the designs or specifications of such product at any time without notice.
 Cashco, Inc. does not assume responsibility for the selection, use or maintenance of any product. Responsibility for proper selection, use and maintenance of any Cashco, Inc. product remains solely with the purchaser.

MODEL DA6 PRODUCT CODER 02/07/20

An "X" in POS 12 followed by a 5-digit control number overrides remaining selections.

D6 POS 3 — POS 5 POS 6 & 7 **7** — POS 10 **0** POS 12 POS 13 **0** POS 15 POS 16 **0E**

POSITION 3 - SIZE			
Size		STD CODE	FULL Opt-81
in	(DN)		
1/2"	(15)	4	J
3/4"	(20)	5	K
1"	(25)	6	L
1-1/4"	(32)	7	M
1-1/2"	(40)	8	N
2"	(50)	9	P
2-1/2"	(65)	A	NA
3"	(80)	B	NA
4"	(100)	C	NA

^ Not available with metal diaphragms.
NA Not Available

POSITION 5 - BODY/COVER DOME MATERIALS			
Materials	CODE	Materials	CODE
DI/DI	1	LCC/SST *	8
BRZ/DI	2	SST/DI	7
BRZ/BRZ	B	SST/CS *	9
CS/DI	4	SST/SST *	A
CS/CS *	5	HC/CS **	G
LCC/LCC *	6	HC/SST **	H

* For Opt-81 Select CS, LCC or SST Loading Chamber Material except in Canada, use SST. See Position 3.
** Sizes 1/2" - 2" Except No 1-1/4".

POSITION 6 & 7 - DIAPHRAGM AND SEAT MATERIALS					
Trim Material	Seat	Diaphragm	O-ring/Seal		CODE
			Static	Dynamic	
17-4PH SST "P"	PA	BC	NBR	SST/TFE u-cup	P2
	CTFE	BC	NBR	SST/TFE u-cup	P3
	PA	NBR	NBR	SST/TFE u-cup	P6
	PA	FK	FK	SST/TFE u-cup	P7 ‡
	GF-TFE	FK	FK	SST/TFE u-cup	P8 ‡
	V-TFE	FK	FK	SST/TFE u-cup	P9 ‡
	PA	FKM	FKM	SST/TFE u-cup	PB
	GF-TFE	FKM	FKM	SST/TFE u-cup	PD
	V-TFE	FKM + TFE	SST/TFE u-cup √	SST/TFE u-cup	PE
	GF-TFE	3-ply	RTFE	SST/TFE u-cup \$	PF
	GF-TFE	3-ply	RTFE	PRA	PG
	PA	NBR	NBR	TFE+NBR CP	PH
	PA	EPR	EPR	TFE+EPR CP	PJ
	PA	FK	FK	TFE+FK CP	PK
GF-TFE	FKM	FKM	TFE+FKM CP	PL	
FKM	FKM	FKM	SST/TFE u-cup	PZ	
Monel "M"	PA	FK	FK	SST/TFE u-cup ‡‡	M7 ‡
	V-TFE	FK	FK	SST/TFE u-cup	M9 ‡
	V-TFE	FKM-TFE	SST/TFE u-cup √	SST/TFE u-cup	ME
316L SST "S"	FKM	FKM	FKM	SST/TFE u-cup	MZ
	PA	FK	FK	SST/TFE u-cup	S7 ‡
	V-TFE	FK	FK	SST/TFE u-cup	S9 ‡
NACE	PA	BE-CU *	SST/TFE u-cup	SST/TFE u-cup	SM
	V-TFE	BE-CU *	SST/TFE u-cup	SST/TFE u-cup	SN
	PA	BC	V-TFE	ELG/TFE u-cup	NP ‡
	PA	NBR	NBR	ELG/TFE u-cup	NR
	PA	FKM	FKM	ELG/TFE u-cup	NS
	FKM	FKM	FKM	ELG/TFE u-cup	NF
	CTFE	NBR	V-TFE	ELG/TFE u-cup	NT ‡
	V-TFE	BC	V-TFE	ELG/TFE u-cup	NV ‡
	PA	FK	FK	SST/TFE u-cup ‡‡	T7 ‡
	V-TFE	FK	FK	SST/TFE u-cup	T9 ‡
17-4PH/ Monel/17-4PH "T"	PA	BE-CU *	SST/TFE u-cup	SST/TFE u-cup	TM
	V-TFE	BE-CU *	SST/TFE u-cup	SST/TFE u-cup	TN

* Metal diaphragm not available w/ Bronze Cover Dome or for sizes 2-1/2" - 4".
‡ For Low Ambient Temperatures (See DAG for Min. Temperatures)
‡‡ For GOX service, PA seats allowed in BRZ Bodies w/ trim materials "M" or "T" only.
√ Sizes 2-1/2"-4" use V-TFE static seal.
\$ For Steam applications Max Press < 125 psig. Abbreviations defined on page 2

POSITION 10 - END CONNECTIONS / ASME								
Size	Material	Method	End Conn	CODE	End Conn	CODE	End Conn	CODE
1/2" - 2"	ALL	—	NPT	1	—	—	—	—
2-1/2" - 4"	DI	Integral	125#FF	2	250#RF	3	—	—
1", 1-1/2" - 4"	BRZ	Integral	150#FF	6	300#FF	7	—	—
1/2" - 3/4"	CS,SST	Opt-30	150#RF	4	300#RF	5	600# RF	8
1" - 4"	CS-SST	Integral *						
1" - 2"	HC	Opt-30 *	—	—	—	—	—	—
1/2" - 2"	ALL	Opt-31	BSPT	P	—	—	—	—
1/2" - 2"	CS, SST	Opt-32	Extended Nipples		—	E	—	—
1/2" - 2" (14" F to F)	CS, SST	Opt-34 *	150#RF	V	300#RF	W	600#RF	Y
1/2" - 1", 1-1/2" - 2	SST	Opt-41	Non-High Purity Tube Ends		—	T	—	—

END CONNECTIONS FOR ISO DIN FLANGES								
DN15-25, 40, 50	BRZ	Integral	PN40 FF - will mate with PN16, 25 and 40			J		
DN65-100			PN16 FF	K	PN25 FF	L	PN40 FF	M
DN15-25, 40, 50	CS, SST, HC	Opt-30	PN40 RF - will mate with PN16, 25 and 40			D		
DN65-100	CS, SST	Integral	PN16 RF	A	PN25 RF	C	PN40 RF	G

* Flanges Not Available for 1-1/4" (DN32) size.
** 1" size w/ 600# RF CS, or SST has weld-on flanges Opt-30 (Not available in HC material)

POSITION 12 - SENSING / LOADING CONFIGURATION (FLOW TO OPEN)		
Option	Sensing Only	Sensing WITH Loading Conf. *
	CODE	CODE
Internal	1	A
External	2	B
Large Internal	4	C
Ratio Loaded	R	D
For Special Construction Contact Cashco for Special Code	X	

*Requires Additional Loading Schematic. See Product Coders 92 thru 98.

*** For information on ATEX see pages 17 & 18 on the IOM.**

POSITION 13 - FEATURE OPTIONS			
Description	Option	CODE	
No Option	—	0	
Bias Spring.	-96	5	

POSITION 15 - BODY OPTIONS			
Description	Option	CODE	
No Option	—	0	
Second Set 1/4" (DN8) FNPT Pressure Taps & Plugs.	-85	T	

POSITION 16 - CERTIFICATE OPTIONS			
Description	Option	CODE	
No Option	—	0	
NACE Construction (Body/Cover Dome); CS/CS, LCC/LCC, LCC/SST, SST/CS, SST/SST per MR0175, All Sizes except 1-1/4" (DN32)	-40	J	
SPECIAL CLEANING: Per Cashco Spec #S-1134. W/ properly selected materials. Suitable for Oxygen Service. BRZ or SST body material.	-55	M	
SPECIAL CLEANING: Per Cashco Spec #S-1542.	-56	N	

Алматы (7273)495-231
Ангарск (3955)60-70-56
Архангельск (8182)63-90-72
Астрахань (8512)99-46-04
Барнаул (3852)73-04-60
Белгород (4722)40-23-64
Благовещенск (4162)22-76-07
Брянск (4832)59-03-52
Владивосток (423)249-28-31
Владикавказ (8672)28-90-48
Владимир (4922)49-43-18
Волгоград (844)278-03-48
Вологда (8172)26-41-59
Воронеж (473)204-51-73
Екатеринбург (343)384-55-89

Иваново (4932)77-34-06
Ижевск (3412)26-03-58
Иркутск (395)279-98-46
Казань (843)206-01-48
Калининград (4012)72-03-81
Калуга (4842)92-23-67
Кемерово (3842)65-04-62
Киров (8332)65-02-04
Коломна (4966)23-41-49
Кострома (4942)77-07-48
Краснодар (861)203-40-90
Красноярск (391)204-63-61
Курск (4712)77-13-04
Курган (3522)50-90-47
Липецк (4742)52-20-81

Магнитогорск (3519)55-03-13
Москва (495)268-04-70
Мурманск (8152)59-64-93
Набережные Челны (8552)20-53-41
Нижний Новгород (831)429-08-12
Новокузнецк (3843)20-46-81
Новосибирск (3496)41-32-12
Новосибирск (383)227-86-73
Омск (3812)21-46-40
Орел (4862)44-53-42
Оренбург (3532)37-68-04
Пенза (8412)22-31-16
Петрозаводск (8142)55-98-37
Псков (8112)59-10-37
Пермь (342)205-81-47

Ростов-на-Дону (863)308-18-15
Рязань (4912)46-61-64
Самара (846)206-03-16
Санкт-Петербург (812)309-46-40
Саратов (845)249-38-78
Севастополь (8692)22-31-93
Севастополь (8642)22-96-24
Симферополь (3652)67-13-56
Смоленск (4812)29-41-54
Сочи (862)225-72-31
Ставрополь (8652)20-65-13
Сургут (3462)77-98-35
Сыктывкар (8212)25-95-17
Тамбов (4752)50-40-97
Тверь (4822)63-31-35

Тольятти (8482)63-91-07
Томск (3822)98-41-53
Тула (4872)33-79-87
Тюмень (3452)66-21-18
Ульяновск (8422)24-23-59
Улан-Удэ (3012)59-97-51
Уфа (347)229-48-12
Хабаровск (4212)92-98-04
Чебоксары (8352)28-53-07
Челябинск (351)202-03-61
Череповец (8202)49-02-64
Чита (3022)38-34-83
Якутск (4112)23-90-97
Ярославль (4852)69-52-93

Россия +7(495)268-04-70 Казахстан +7(7172)727-132 Киргизия +996(312)96-26-47

<https://cashco.nt-rt.ru/> || coc@nt-rt.ru