

MODEL 3100

PRESSURE/VACUUM VENT END-OF-LINE

OVERVIEW

The Model 3100 end-of-line conservation breather vent is designed for use on atmospheric and low-pressure storage tanks where pressure and vacuum relief is required.

SPECIAL FEATURES

Modular Design: The Model 3100 end-of-line conservation breather vent is part of the Valve Concepts, Inc. modular vent product line. The Model 3100 can easily be field converted to a vacuum only vent, a pressure/vacuum vent with pipe away and can either be direct acting or pilot operated. Only Valve Concepts offers complete modularity throughout its complete vent product line.

Maintains Accurate Settings: Minimum setting available is approximately 0.25 OZ/IN² for both pressure and vacuum relief. Maximum setting upwards to 2.5 psig for pressure and 2 psig for vacuum, see Set Point Limits Table 4. If higher settings are required, see Valve Concepts Series 4000 Spring Loaded Vents or Valve Concepts Series 5000 Pilot Operated Vents. All vents are tested to Valve Concepts, Inc. high standards for both leakage and set point prior to shipment. A certified test certificate is included with each vent verifying the accuracy of both the pressure and vacuum setting and leakage. Seat leakage meets or exceeds API Standard 2000 for both pressure and vacuum.

Condensate Drainage: Self-draining body and specially designed seat ring keeps condensate away from seating surfaces, preventing freezing, binding, and logging.

Air-Cushioned Seating: Air-cushion seating provides tight sealing to reduce evaporation losses and the release of toxic vapors. The pallets have outer guiding and center stabilizing stem to provide self alignment and tight seating.

Sizes-Connections: Available in line sizes 2" (DN50) through 12" (DN300). Carbon steel and stainless steel vents have raised face tank connection flange. All other vent materials come standard with flat face flanges. Standard flanged bolt patterns are available to mate with ASME Class 150, DIN PN16, or DIN PN10 flanged connections. PN10 is available on DN200, DN250, and DN300 sizes only.

*Derakane 470 and Hetron 800 are registered trademarks of Ashland, inc.

TECHNIQUE

Weight loaded pallets in the vent housing allow the intake of air and the escape of vapors as the tank breathes due to thermal changes and product movement in and out of the tank. The pallets open and close to permit in breathing and out breathing necessary to maintain the tank pressure within permissible limits to avoid damage to the tank.



MODEL 3100



LINE SIZES AVAILABLE

2" (DN50), 3" (DN80), 4" (DN100), 6" (DN150), 8" (DN200), 10" (DN250), 12" (DN300)



END CONNECTIONS FLANGED



COMMON APPLICATIONS

ATMOSPHERIC & LOW-PRESSURE
STORAGE TANKS



DESIGN PRESSURE

MULTIPLE SET PRESSURE & VACUUM
RANGES AVAILABLE

Алматы (7273)495-231
Ангарск (3955)60-70-56
Архангельск (8182)63-90-72
Астрахань (8512)99-46-04
Барнаул (3852)73-04-60
Белгород (4722)40-23-64
Благовещенск (4162)22-76-07
Брянск (4832)59-03-52
Владивосток (423)249-28-31
Владикавказ (8672)28-90-48
Владимир (4922)49-43-18
Волгоград (844)278-03-48
Вологда (8172)26-41-59
Воронеж (473)204-51-73
Екатеринбург (343)384-55-89

Иваново (4932)77-34-06
Ижевск (3412)26-03-58
Иркутск (395)279-98-46
Казань (843)206-01-48
Калининград (4012)72-03-81
Калуга (4842)92-23-67
Кемерово (3842)65-04-62
Киров (8332)68-02-04
Коломна (4966)23-41-49
Кострома (4942)77-07-48
Краснодар (861)203-40-90
Красноярск (391)204-63-61
Курск (4712)77-13-04
Курган (3522)50-90-47
Липецк (4742)52-20-81

Магнитогорск (3519)55-03-13
Москва (495)268-04-70
Мурманск (8152)59-64-93
Набережные Челны (8552)20-53-41
Нижний Новгород (831)429-08-12
Новокузнецк (3843)20-46-81
Ноябрьск (3496)41-32-12
Новосибирск (383)227-86-73
Омск (3812)21-46-40
Орел (4862)44-53-42
Оренбург (3532)37-68-04
Пенза (8412)22-31-16
Петрозаводск (8142)55-98-37
Псков (8112)59-10-37
Пермь (342)205-81-47

Ростов-на-Дону (863)308-18-15
Рязань (4912)46-61-64
Самара (846)206-03-16
Санкт-Петербург (812)309-46-40
Саратов (845)249-38-78
Севастополь (8692)22-31-93
Саранск (8342)22-96-24
Симферополь (3652)67-13-56
Смоленск (4812)29-41-54
Сочи (862)225-72-31
Ставрополь (8652)20-65-13
Сургут (3462)77-98-35
Сыктывкар (8212)25-95-17
Тамбов (4752)50-40-97
Тверь (4822)63-31-35

Тольятти (8482)63-91-07
Томск (3822)98-41-53
Тула (4872)33-79-87
Тюмень (3452)66-21-18
Ульяновск (8422)24-23-59
Улан-Уда (3012)59-97-51
Уфа (347)229-48-12
Хабаровск (4212)92-98-04
Челябск (8352)28-53-07
Челябинск (351)202-03-61
Череповец (8202)49-02-64
Чита (3022)38-34-83
Якутск (4112)23-90-97
Ярославль (4852)69-52-93

Россия +7(495)268-04-70

Казахстан +7(7172)727-132

Киргизия +996(312)96-26-47

CONSTRUCTION

Housing Material: Available in aluminum, carbon steel, 316 stainless steel, 304 or corrosion resistance fiberglass reinforced plastic (FRP) with Derakane 470* or Hetrion 800* resins.

Seat Rings: Replaceable metal seat rings available in aluminum, 304 stainless steel, or 316 stainless steel. FRP vents have integral seats that match the body resin material.

Pallets Assemblies: Replaceable 316 stainless steel pallet assemblies are standard for metal vents. Pallet assemblies lower than 0.5 OZ/IN² may contain a polycarbonate pallet material. Replaceable FRP pallet assemblies match the body resin material.

Pallet Diaphragms: Standard diaphragm material is FEP film. Also available in FKM, EPDM, and Buna-N.

STANDARD/GENERAL SPECIFICATIONS

Gaskets: Expanded PTFE tape.

Pressure and Vacuum Protection Screens: Replaceable 4x4 welded mesh screens in 304 stainless steel to prevent obstructions to pressure and vacuum relief flow paths.

Set Point Accuracy: Pressure and vacuum setpoints are calibrated to be within +/-2% of customer requested setting across the range of available settings. Exceeds API Bulletin 2521.

Seat Leakage: Seat leakage rate of less than 1 SCFH of air at 75% of set point. Exceeds API Bulletin 2521.

Calibration Certificate: Calibration certificates are issued standard with every line item demonstrating acceptable set point accuracy and seat leakage rates.

Painting: All carbon steel surfaces are epoxy coated VCI blue per Cashco specification S-1777. Flange mating surfaces, threaded holes, and corrosion resistant parts are excluded. Non-coated surfaces have lubricant applied for corrosion prevention.

Flange Studs: 304 stainless steel studs supplied for threaded holes in connection flange. UNC threaded studs are supplied for Class 150 threaded holes. Metric studs are supplied for PN10 and PN16 threaded holes. Flange bolting is not supplied for remaining thru holes in connection flange or with FRP body materials.

OPTION SPECIFICATIONS

Vacuum Flame Screen: Replaceable 30x30 mesh screen in 304 stainless steel. Used to help prevent ignition of internal vapors through the vacuum relief port. This option replaces the standard vacuum protection screen.

Sizing Report: Formal report documenting tank inbreathing/oubreathing requirements and vent performance per customer application. Displacement flow requirements and vent performance are in accordance with the current edition of API 2000 Std.

NACE Certification: Internal wetted portions meet NACE standard MR0175 when exterior of the vent is not directly exposed to a sour gas environment, buried, insulated, or otherwise denied direct atmospheric exposure. Available for carbon steel or 316 stainless steel body materials only. Must be requested at time of order.

Oxygen Cleaning: All components oxygen cleaned, bagged, and tagged in accordance to Cashco specification S-1134. Must select either 304 or 316 stainless steel body materials and stainless steel loading weights.

ATEX 2014/34/EU: Declaration of Conformity and appropriate nameplate markings available. Must be requested at time of order. See Model 3100 IOM for more details.

PED 2014/34/EU Certificate: Sound Engineering Practice (SEP) certificate available for pressures up to 0.5 barg. For higher pressures, a Declaration of Conformity, pressure testing, MTR's, and appropriate nameplate markings are available for Hazard Category I only. Must be requested at time of order.

TABLE 1 - MATERIALS OF CONSTRUCTION						
COMPONENT MATERIALS	BODY MATERIALS					
	ALUM	CS	316 SST	304 SST	DERAKANE 470	HETRON 800
VACUUM COVER	ALUM	CS	316 SST	304 SST	DERAKANE 470	HETRON 800
WEATHER HOOD	ALUM ¹	304 SST	304 SST	304 SST	DERAKANE 470	HETRON 800
SEAT RINGS	ALUM, 316 SST	316 SST	316 SST	304 SST	DERAKANE 470	HETRON 800
PALLET ASSEMBLIES	PC ² , 316 SST	PC ² , 316 SST	PC ² , 316 SST	PC ² , 316 SST	DERAKANE 470	HETRON 800
VACUUM PALLET GUIDES	316 SST	316 SST	316 SST	316 SST	DERAKANE 470	HETRON 800
Weather Hood Supports	316 SST	316 SST	316 SST	316 SST	DERAKANE 470	HETRON 800
FLANGE STUDS	304 SST	304 SST	304 SST	304 SST	N/A	N/A
FASTENERS	316 SST	316 SST	316 SST	316 SST	316 SST, ALLOY C276	316 SST, ALLOY C276
PALLET WEIGHTS	CS ³ , SST	CS ³ , SST	CS ³ , SST	CS ³ , SST	DERAKANE 470 ⁴	HETRON 800 ⁴
SCREENS	304 SST	304 SST	304 SST	304 SST	POLYETHYLENE	POLYETHYLENE

1 - May be substituted with 304 SST at factory discretion.
2 - Polycarbonate pallet material may be used for settings less than 0.5 OZ/IN². All other parts are 316 SST.
3 - Carbon steel pallet weights are epoxy coated per Cashco specification S-1777.
4 - FRP encapsulated carbon steel utilizes same resin as body.

TABLE 2 - PRESSURE/TEMPERATURE RATINGS				
BODY MATERIAL	MAWP		Temperature	
	PSI	(BAR)	°F	(°C)
Aluminum	15	(1)	-325/+250	(-198/+121)
Carbon Steel	15	(1)	-20/+400	(-28/+204)
316 Stainless Steel	15	(1)	-325/+400	(-198/+204)
304 Stainless Steel	15	(1)	-325/+400	(-198/+204)
Derakane 470*	2	(0.14)	N/A	
Hetron 800*	2	(0.14)	N/A	

* Temperature limits vary based on resin material, media, concentration, and storage temperature. Consult factory for more information.

TABLE 3 - DIAPHRAGM TEMPERATURE LIMITS		
Material	°F	(°C)
FEP	-400/+400	(-240/+204)
Buna-N	-40/+250	(-40/+121)
EPDM	-40/+225	(-40/+107)
FKM	-20/+400	(-28/+204)

TABLE 4 - SET POINT LIMITS									
Metallic Vents (OZ/IN ²)					FRP Vents (OZ/IN ²)				
Size	Pressure		Vacuum		Size	Pressure		Vacuum	
	MIN	MAX	MIN	MAX*		MIN	MAX	MIN	MAX
2"	0.30	34.10	0.26	33.40	2"	0.50	32.00	0.50	8.00
3"	0.27	36.90	0.22	35.70	3"	0.50	32.00	0.50	8.00
4"	0.19	43.10	0.17	38.80	4"	0.50	32.00	0.50	8.00
6"	0.19	39.80	0.17	38.10	6"	0.50	32.00	0.50	8.00
8"	0.19	39.70	0.18	38.80	8"	0.50	32.00	0.50	8.00
10"	0.20	42.10	0.20	29.90	10"	0.50	32.00	0.50	8.00
12"	0.20	35.70	0.19	21.80	12"	0.50	32.00	0.50	8.00

* May require use of extended vacuum cover at factory discretion

MODEL 3100 REV C PRESSURE RELIEF
WIDE OPEN CAPACITY

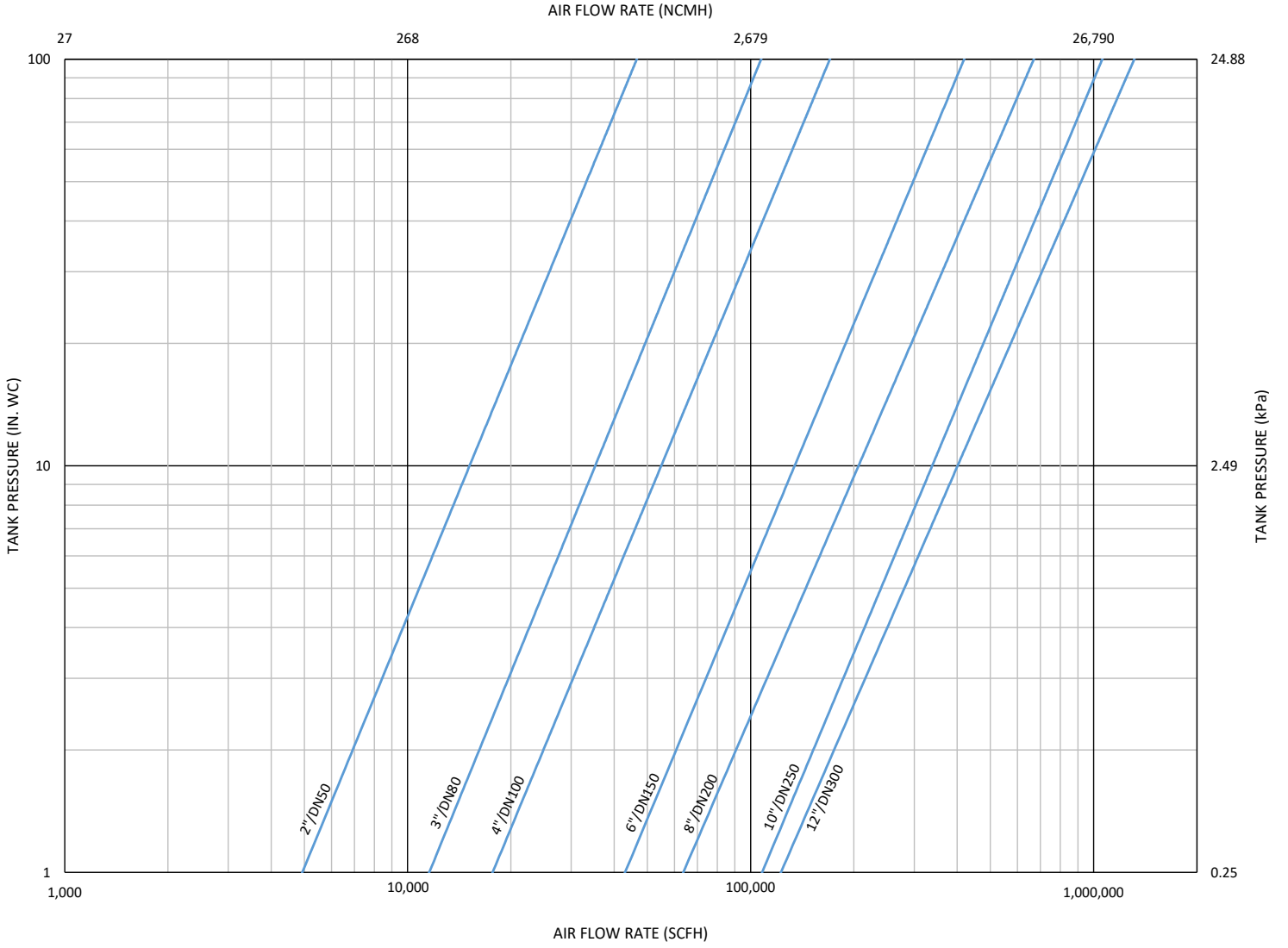

MODEL 3100 REV C VACUUM RELIEF
WIDE OPEN CAPACITY

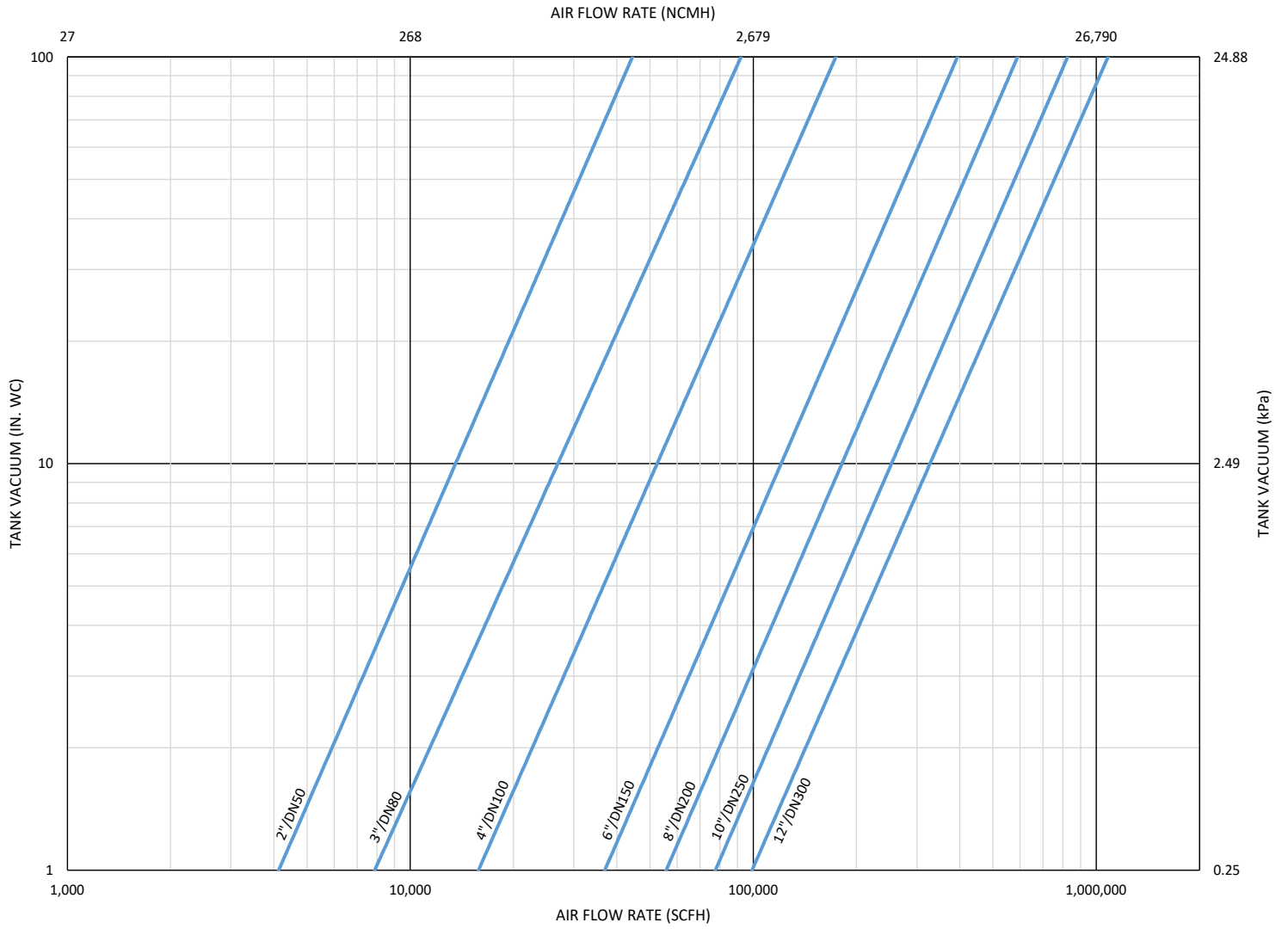

DIMENSIONS
Metallic Vent Construction

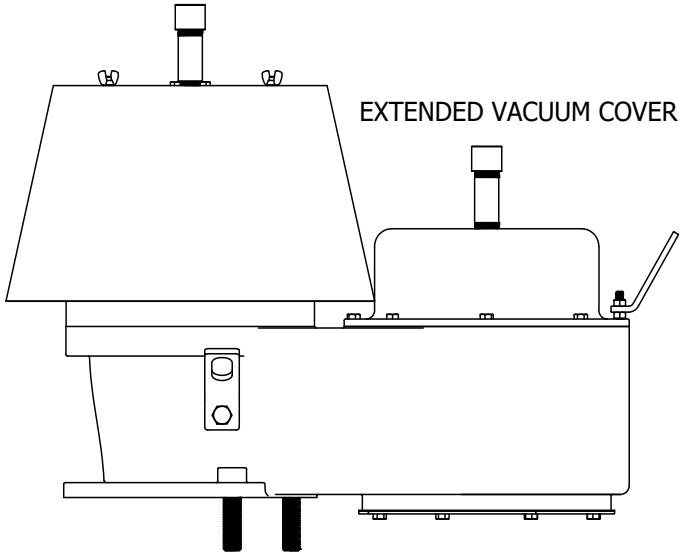
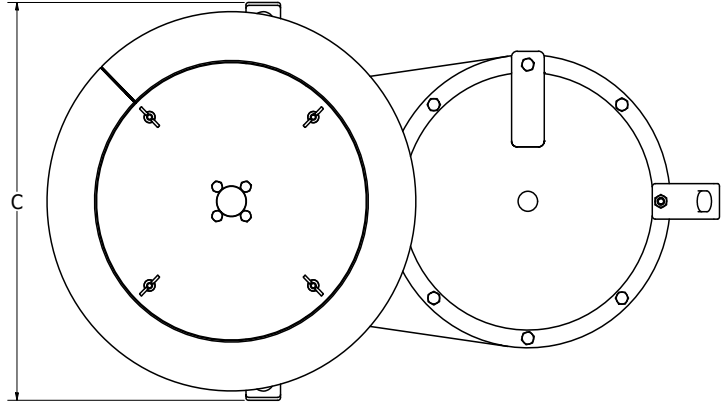
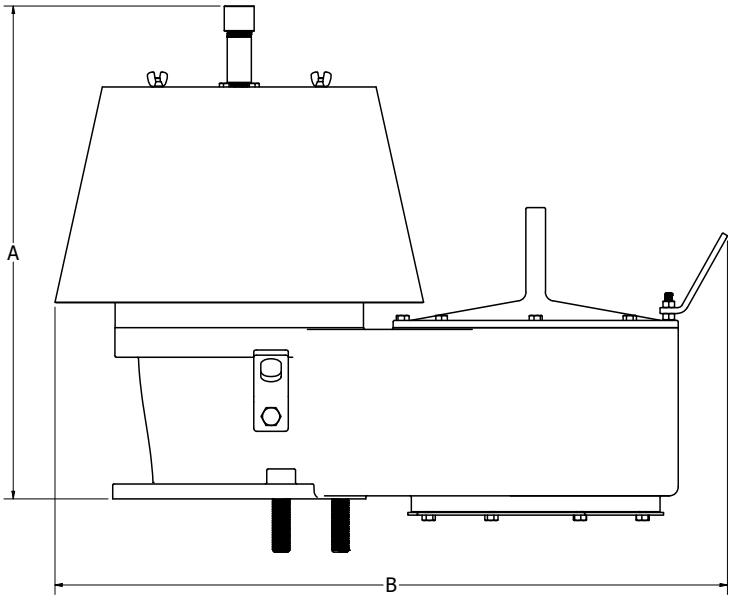

Metallic Vent Dimensions					
Line Size	Dimensions (inches)			Weight* (lbs)	
	A	B	C	Alum	CS/SST
2"	13.5	18.1	12.4	25	52
3"	16.9	19.4	14.1	31	66
4"	19.4	25.0	16.3	50	105
6"	21.3	29.2	16.8	70	149
8"	26.0	35.1	20.4	91	213
10"	27.4	41.6	21.3	141	303
12"	30.6	44.9	24.4	161	409
Line Size	Dimensions (mm)			Weight* (kgs)	
	A	B	C	Alum	CS/SST
DN50	343	459	316	11	24
DN80	428	492	357	14	30
DN100	493	634	413	23	48
DN150	541	742	427	32	68
DN200	661	891	519	41	97
DN250	695	1057	541	64	137
DN300	776	1141	619	73	186

* Weight based on MIN pressure and vacuum settings without shipping materials.

DIMENSIONS
Firberglass Reinforced Plastic (FRP) Construction

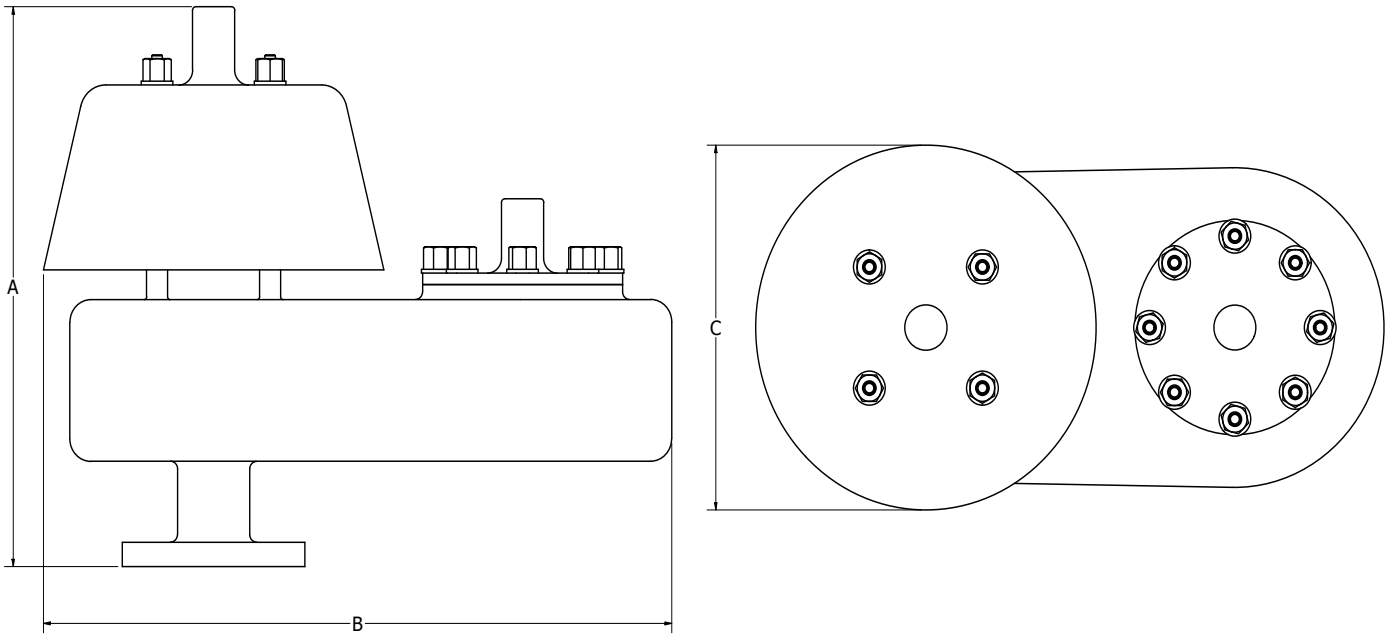

FRP Vent Dimensions				
Line Size	Dimensions (inches)			Weight* (lbs)
	A	B	C	
2"	18.6	26.6	12.1	17
3"	18.6	26.6	12.1	18
4"	22.5	36.1	16.4	30
6"	24.5	35.8	17.0	33
8"	29.8	48.8	23.3	57
10"	30.5	48.6	23.8	61
12"	31.5	52.6	26.9	72
Line Size	Dimensions (mm)			Weight* (kgs)
	A	B	C	
DN50	471	675	308	8
DN80	471	675	308	8
DN100	572	917	417	14
DN150	623	909	432	15
DN200	756	1241	592	26
DN250	775	1235	603	28
DN300	799	1335	683	33
* Weight based on MIN pressure and vacuum settings without shipping materials.				

The contents of this publication are presented for informational purposes only, and while every effort has been made to ensure their accuracy, they are not to be construed as warranties or guarantees, express or implied, regarding the products or services described herein or their use or applicability. We reserve the right to modify or improve the designs or specifications of such product at any time without notice. Cashco, Inc. does not assume responsibility for the selection, use or maintenance of any product. Responsibility for proper selection, use and maintenance of any Cashco, Inc. product remains solely with the purchaser.

3100 Series PRODUCT CODE 10/12/20



POSITION 3 - FLANGE CONNECTION	
ASME 150	A
PN16	B
PN10	C

POSITION 4 - FLANGE SIZE	
INCH (DIN)	CODE
2" (DN50)	2
3" (DN80)	3
4" (DN100)	4
6" (DN150)	6
8" (DN200)	8
10" (DN250)	A
12" (DN300)	B

POSITION 5 - BODY/SEAT RING MATERIAL		
BODY MATERIAL	SEAT MATERIAL	CODE
Aluminum	Aluminum	1
Aluminum	316 Stainless Steel	4
Carbon Steel	316 Stainless Steel	5
316 Stainless Steel	316 Stainless Steel	6
304 Stainless Steel	304 Stainless Steel	7
Derakane 470 w/ SST Studs	Derakane 470	D
Derakane 470 w/ Hast C Studs	Derakane 470	E
Hetron 800 w/ SST Studs	Hetron 800	F
Hetron 800 w/ Hast C Studs	Hetron 800	G

POSITION 7 - DIAPHRAGM MATERIAL	
FEP (Std)	A
Buna-N	B
EPDM	D
FKM	F

POSITION 8 - PRESSURE PALLET CONFIGURATION	
Set Point Range - OZ/IN ²	CODE
MIN - 0.49	1
0.50 - 0.74	2
0.75 - 7.99	3
8.00 - MAX	4

See Table 4 for MIN and MAX pressure set points.

POSITION 9 - VACUUM PALLET CONFIGURATION	
Set Point Range - OZ/IN ²	CODE
MIN - 0.49	1
0.50 - 0.74	2
0.75 - 7.99	3
8.00 - MAX	4

See Table 4 for MIN and MAX vacuum set points.

POSITION 10 - WEIGHT MATERIAL	
Epoxy Coated Carbon Steel	0
Stainless Steel	S
FRP Encapsulated Steel	E

POSITION 11 - VACUUM SCREEN	
Standard Screen	0
Flame Screen	F

POSITION 12 - CLEANING METHOD	
Standard Cleaning	0
Oxygen Cleaning	M

Алматы (7273)495-231
 Ангарск (3955)60-70-56
 Архангельск (8182)63-90-72
 Астрахань (8512)99-46-04
 Барнаул (3852)73-04-60
 Белгород (4722)40-23-64
 Благовещенск (4162)22-76-07
 Брянск (4832)59-03-52
 Владивосток (423)249-28-31
 Владикавказ (8672)28-90-48
 Владимир (4922)49-43-18
 Волгоград (844)278-03-48
 Вологда (8172)26-41-59
 Воронеж (473)204-51-73
 Екатеринбург (343)384-55-89

Иваново (4932)77-34-06
 Ижевск (3412)26-03-58
 Иркутск (395)279-98-46
 Казань (843)206-01-48
 Калининград (4012)72-03-81
 Калуга (4842)92-23-67
 Кемерово (3842)65-04-62
 Киров (8332)68-02-04
 Коломна (4966)23-41-49
 Кострома (4942)77-07-48
 Краснодар (861)203-40-90
 Красноярск (391)204-63-61
 Курск (4712)77-13-04
 Курган (3522)50-90-47
 Липецк (4742)52-20-81

Магнитогорск (3519)55-03-13
 Москва (495)268-04-70
 Мурманск (8152)59-64-93
 Набережные Челны (8552)20-53-41
 Нижний Новгород (831)429-08-12
 Новокузнецк (3843)20-46-81
 Ноябрьск (3496)41-32-12
 Новосибирск (383)227-86-73
 Омск (3812)21-46-40
 Орел (4862)44-53-42
 Оренбург (3532)37-68-04
 Пенза (8412)22-31-16
 Петрозаводск (8142)55-98-37
 Псков (8112)59-10-37
 Пермь (342)205-81-47

Ростов-на-Дону (863)308-18-15
 Рязань (4912)46-61-64
 Самара (846)206-03-16
 Санкт-Петербург (812)309-46-40
 Саратов (845)249-38-78
 Севастополь (8692)22-31-93
 Саранск (8342)22-96-24
 Симферополь (3652)67-13-56
 Смоленск (4812)29-41-54
 Сочи (862)225-72-31
 Ставрополь (8652)20-65-13
 Сургут (3462)77-98-35
 Сыктывкар (8212)25-95-17
 Тамбов (4752)50-40-97
 Тверь (4822)63-31-35

Тольятти (8482)63-91-07
 Томск (3822)98-41-53
 Тула (4872)33-79-87
 Тюмень (3452)66-21-18
 Ульяновск (8422)24-23-59
 Улан-Уда (3012)59-97-51
 Уфа (347)229-48-12
 Хабаровск (4212)92-98-04
 Чебоксары (8352)28-53-07
 Челябинск (351)202-03-61
 Череповец (8202)49-02-64
 Чита (3022)38-34-83
 Якутск (4112)23-90-97
 Ярославль (4852)69-52-93

Россия +7(495)268-04-70

Казахстан +7(7172)727-132

Киргизия +996(312)96-26-47

<https://cashco.nt-rt.ru/> || coc@nt-rt.ru