

**CONSTRUCTION**

**Body Material:** Available in Aluminum, Carbon Steel or 316 SST.

**Numerous Sizes.** Available in Sizes 2" through 12". CS & SST vents have Raised Face Flange, Aluminum vents have Flat Face Flange to mate with ASME150# flange connections.

**Diaphragm Case Material:** Available in Carbon Steel or Stainless Steel.

**Pallet Diaphragm Material:** FKM - Standard; also available EPDM or FEP-TFE.

**Pilot Body Material:** 316SST.

**Pilot Seat (o-ring):** FKM - Standard; also available EPDM, FFKM 1 or FFKM 2.

**Pilot (Sensing) Diaphragm:** FEP-TFE.

**SPECIAL FEATURES**

**Modular:** The Model 5200 pipe-away conservation vent is part of the Valve Concepts, Inc. modular vent product line. The Model 5200 can easily be converted to a vacuum only vent or end-of-line pressure / vacuum vent and can either be direct activating or pilot operated.

**Maintains Accurate Settings.** The Pilot Operated Model 5200 provides bubble tight (no leakage) up to 95% of set pressure or 0.5" WC, whichever is greater and less than 1 SCFH at 90% of setting on the vacuum side of the vent. A certified test certificate is included with each vent verifying the accuracy of both the pressure and vacuum setting and leakage.

**Condensate Drainage.** Self-draining housing body and drip rings keep condensate away from seating surfaces, preventing freezing, binding and clogging.

**Air-Cushioned Seating.** Air-cushion seating provides tight sealing to reduce evaporation losses. The pallets have outer guiding and center stabilizing stem to provide self alignment and tight seating.



**Model 5200  
PILOT OPERATED**

**Pressure / Vacuum Vent with Pipe-Away**

**OBJECTIVE**

The Pilot Operated Model 5200 vent provides pressure and vacuum relief in applications that require vapors to be piped away.

**TECHNIQUE**

The Model 5200 has a pilot operated pressure side which permits tank operating pressures closer to the maximum allowable operating pressure. This provides a more positive control over vapor generation inherent in fluids with higher vapor pressures. The vacuum side of the vent is weight loaded and allows intake of air when necessary to remain within the vacuum design rating of the tank.

**MATERIALS OF CONSTRUCTION**

Series	Housing	Trim	Diaphragm Cases	Tube & Fittings
5200CS	CS	316 SST	CS	CS
5200SST	316 SST	316 SST	SST	SST
5200A	Aluminum	Aluminum	CS	CS®

Алматы (7273)495-231  
 Ангарск (3955)60-70-56  
 Архангельск (8182)63-90-72  
 Астрахань (8512)99-46-04  
 Барнаул (3852)73-04-60  
 Белгород (4722)40-23-64  
 Благовещенск (4162)22-76-07  
 Брянск (4832)59-03-52  
 Владивосток (423)249-28-31  
 Владикавказ (867)28-90-48  
 Владимир (4922)49-43-18  
 Волгоград (844)278-03-48  
 Вологда (8172)26-41-59  
 Воронеж (473)204-51-73  
 Екатеринбург (343)384-55-89

Иваново (4932)77-34-06  
 Ижевск (3412)26-03-58  
 Иркутск (395)279-98-46  
 Казань (843)206-01-48  
 Калининград (4012)72-03-81  
 Калуга (4842)92-23-67  
 Кемерово (3842)65-04-62  
 Киров (8332)68-02-04  
 Коломна (4966)23-41-49  
 Кострома (4942)77-07-48  
 Краснодар (861)203-40-90  
 Красноярск (391)204-63-61  
 Курск (4712)77-13-04  
 Курган (3522)50-90-47  
 Липецк (4742)52-20-81

Магнитогорск (3519)55-03-13  
 Москва (495)268-04-70  
 Мурманск (8152)59-64-93  
 Набережные Челны (8552)20-53-41  
 Нижний Новгород (831)429-08-12  
 Новокузнецк (3843)20-46-81  
 Ноябрьск (3496)41-32-12  
 Новосибирск (383)227-86-73  
 Омск (3812)21-46-40  
 Орел (4862)44-53-42  
 Оренбург (3532)37-68-04  
 Пенза (8412)22-31-16  
 Петрозаводск (8142)55-98-37  
 Псков (8112)59-10-37  
 Пермь (342)205-81-47

Ростов-на-Дону (863)308-18-15  
 Рязань (4912)46-61-64  
 Самара (846)206-03-16  
 Санкт-Петербург (812)309-46-40  
 Саратов (845)249-38-78  
 Севастополь (8692)22-31-93  
 Саранск (8342)22-96-24  
 Симферополь (3652)67-13-56  
 Смоленск (4812)29-41-54  
 Сочи (862)225-72-31  
 Ступино (8652)20-65-13  
 Сургут (3462)77-98-35  
 Петрозаводск (8142)55-98-37  
 Тамбов (4752)50-40-97  
 Тверь (4822)63-31-35

Тольятти (8482)63-91-07  
 Томск (3822)98-41-53  
 Тула (4872)33-79-87  
 Тюмень (3452)66-21-18  
 Ульяновск (8422)24-23-59  
 Улан-Уда (3012)59-97-51  
 Уфа (347)229-48-12  
 Хабаровск (4212)92-98-04  
 Чебоксары (8352)25-53-07  
 Челябинск (351)202-03-61  
 Череповец (8202)49-02-64  
 Чита (3022)38-34-83  
 Якутск (4112)23-90-97  
 Ярославль (4852)69-52-93

## STANDARD/GENERAL SPECIFICATIONS

**Spring Ranges:**

PRESSURE RANGE	
in WC	(mbar)
1.2" to 2.0" *	(2.9 to 4.9) *
2.1" to 12.0"	(4.9 to 29.9)
12.1" to 18.0"	(30.0 to 44.8)
18.1" to 36.0"	(44.9 to 89.4)
36.1" to 41.7"	(89.5 to 103.5)
41.8" to 86.0"	(103.6 to 214)
PSIG	(Barg)
3.2 to 15.0 psig	(0.22 to 1.03 bar)
* Pressure range 1.2" to 4.0" WC require external air assist to the pilot.	

VACUUM RANGE	
Weight Loaded	
oz/in <sup>2</sup> -psig	mbar-barg
0.5 - 0.5	2.15 - .03
Spring Ranges	
psig	Barg
> 0.5 - 4	.03 - .27
> 4 - 6	.27 - .41
> 6 - 8	.41 - .55
> 8 - 10	.55 - .68
> 10 - 12	.68 - .83
> 12 - 13	.83 - .89
> 13 - 15	.89 - 1.03
* Steel or Steel / SST combination	

**Diaphragm Temperature Limits:**  
FEP-TFE: -400° to 400° F (-240° to 204°C)  
FKM (Fluorocarbon Elastomer): -20° to 400° F (-28° to 204°C)  
EPDM (Ethylenepropylene): -40° to 225° F (-40° to 107°C)

**Seat & Seal Materials Temperature Limits:**  
FKM (Fluorocarbon Elastomer): -15° to 300° F (-26° to 149° C)  
EPDM (Ethylenepropylene): -55° F to 212° F (-48° C to 100° C)  
FFKM 1 (Perfluoroelastomer): -22° F to 400° F (-30° C to 204° C)  
FFKM 2 (Perfluoroelastomer): -40° F to 400° F (-40° C to 204° C)

**Painting:** Standard: Exterior coating will be a combination of Cashco Paint Specs #S-1777 epoxy and #S-1743 powder coated. Tubing, fasteners, seat surfaces - corrosion resistant parts excluded.

**Pressure & Vacuum Ranges:** See Position 8 and 10 on the coder. Differential Pressures greater than 2 psid will limit the minimum vacuum set point to 2 oz/in<sup>2</sup>.

## OPTION SPECIFICATIONS

**BUG SCREEN** - 304 stainless steel, 4x4 welded mesh.

**FLAME SCREEN** - 304 stainless steel, 30x30 woven mesh

## DIMENSIONS

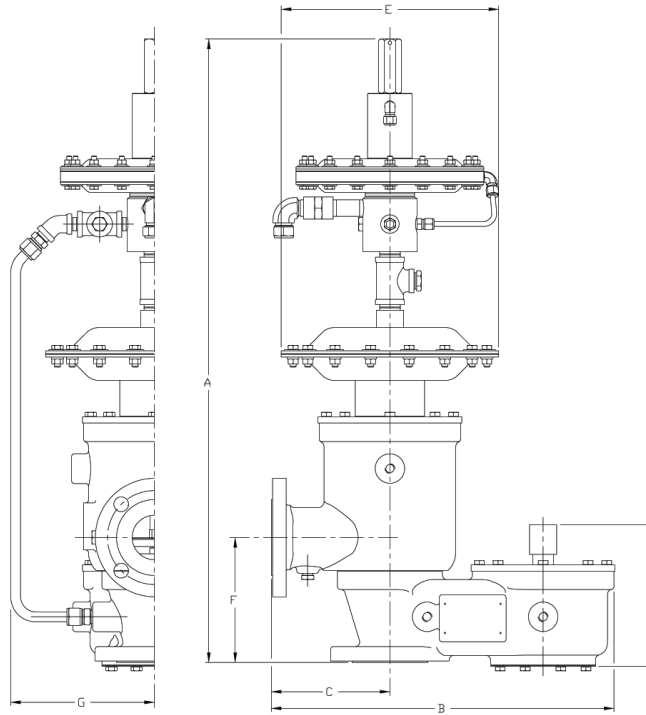

ENGLISH Units - in Aluminum, Carbon Steel & Stainless Steel								Weight - lbs.	
SIZE In	A	B	C	D	E (diam)	F	G	Alum	CS / SST
2" x 2"	31.75	17.33	6.00	7.17	11.00	6.32	7.75	75	129
2" x 3"	31.75	17.52	6.19	7.17	11.00	6.88	7.75	78	133
3" x 3"	34.50	18.81	6.50	8.60	11.00	8.06	7.75	94	156
3" x 4"	34.50	18.81	6.50	8.60	11.00	8.56	7.75	95	160
4" x 4"	40.75	24.38	8.00	10.56	16.50	9.55	9.25	155	254
4" x 6"	40.75	24.38	8.00	10.56	16.50	10.55	9.25	158	258
6" x 6"	42.38	29.00	9.00	11.84	16.50	11.03	9.25	185	289
6" x 8"	42.38	29.00	9.00	11.84	16.50	12.22	9.25	192	300
8" x 10"	47.38	33.84	11.00	15.59	23.81	15.27	12.94	355	571
10" x 12"	49.25	40.38	12.25	15.44	23.81	16.44	13.25	478	765
12" x 14"	51.88	43.50	14.00	17.18	23.81	18.40	13.38	559	891

METRIC Units - mm Aluminum, Carbon Steel & Stainless Steel								Weight - kg	
SIZE (DN)	A	B	C	D	E (diam)	F	G	Alum	CS / SST
(50) x (50)	806	440	152	182	279	160	197	35	59
(50) x (80)	806	445	157	182	279	175	197	36	61
(80) x (80)	876	478	165	218	279	204	197	43	71
(80) x (100)	876	478	165	218	279	217	197	44	73
(100) x (100)	1035	619	203	268	419	242	235	71	115
(100) x (150)	1035	619	203	268	419	268	235	72	117
(150) x (150)	1076	737	229	301	419	280	235	84	131
(150) x (200)	1076	737	229	301	419	310	235	87	136
(200) x (250)	1203	859	279	396	605	388	329	161	259
(250) x (300)	1251	1026	311	392	605	417	336	217	347
(300) x (350)	1318	1105	356	436	605	467	340	254	404

The contents of this publication are presented for informational purposes only, and while every effort has been made to ensure their accuracy, they are not to be construed as warranties or guarantees, express or implied, regarding the products or services described herein or their use or applicability. We reserve the right to modify or improve the designs or specifications of such product at any time without notice. Cashco, Inc. does not assume responsibility for the selection, use or maintenance of any product. Responsibility for proper selection, use and maintenance of any Cashco, Inc. product remains solely with the purchaser.

# 5200 Series PRODUCT CODE

02/07/20

Last 6 Characters reserved for SPQ drawing numbers assigned by Cashco Inc.  
(Format as - # # # # # #)



POSITION 3 - INLET SIZE			
INCH	CODE	DIN FLANGE DN (rating)	CODE
2"	2	50 (PN16)	H
3"	3	80 (PN16)	J
4"	4	100 (PN16)	K
6"	6	150 (PN16)	L
8" *	8	200 * (PN10)	M
		200 * (PN16)	T
10" *	A	250 * (PN10)	N
		250 * (PN16)	V
12" *	B	300 * (PN10)	P
		300 * (PN16)	W

\* 8" inlet only available w/10" outlet.  
\* 10" inlet only available w/12" outlet.  
\* 12" inlet only available w/14" outlet.

POSITION 4 - OUTLET SIZE			
INCH	CODE	DIN FLANGE DN (rating)	CODE
2"	2	50 (PN16)	H
3"	3	80 (PN16)	J
4"	4	100 (PN16)	K
6"	6	150 (PN16)	L
8"	8	200 (PN10)	M
		200 (PN16)	T
10" *	A	250 * (PN10)	N
		250 * (PN16)	V
12" *	B	300 * (PN10)	P
		300 * (PN16)	W
14" *	C	350 * (PN10)	R
		350 * (PN16)	Y

POSITION 5 BODY / TRIM MATERIALS			
Material	Std. W/O Flamescreen	W/ Flame Screen	W/ Bug Screen
	CODE	CODE	CODE
ALUM/ALUM *	A	B	M
ALUM/SST *	K	L	N
CS/SST	C	D	P
SST/SST	S	T	R

\* Alum vents have Flat Face flange, CS & SST vents have Raised Face flange

POSITION 8 - PRESSURE RANGES		Std. Constr.	W/ AIR ASSIST
Spring Range		CODE	CODE
1.2" - 2.0" WC (2.9 - 4.9 mbar)		--	L
2.1" - 12.0" WC (4.9 - 29.9 mbar)		3	C
12.1" - 18.0" WC (30.0 - 44.8 mbar)		6	D
18.1" - 36" WC (44.9 - 89.4 mbar)		7	E
36.1" - 41.7" WC (89.5 - 103.5 mbar)		8	F
41.8" - 86.0" WC (103.6 - 214 mbar)		9	J
3.2 - 15.0 psig (0.22 - 1.03 bar)		H	K

POSITION 9 - PILOT SEAT / PALLET DIAPH. / ACT. DIAPH.	
Materials	CODE
FFKM 1 / FEP / FEP	C
EPDM / EPDM / EPDM	E
FFKM 2 / FEP / FEP	K
FKM / FKM / FKM	V

POSITION 10 - VACUUM RANGES			
Weight Loaded		WEIGHT MATERIAL	
oz/in <sup>2</sup> -psig	mbar-barg	STD *	SST
Spring Ranges		CODE	CODE
psig	Barg	CODE	
0.5 - 0.5	2.15 - .03	1	A
> 0.5 - 4	.03 - .27	2	
> 4 - 6	.27 - .41	3	
> 6 - 8	.41 - .55	4	
> 8 - 10	.55 - .68	5	
> 10 - 12	.68 - .83	6	
> 12 - 13	.83 - .89	7	
> 13 - 15	.89 - 1.03	8	

\* Steel or Steel / SST combination

POSITION 11 - OPTIONS With Backflow Preventer (Opt. 2 - 6 Pilot Exhaust to Main Valve Outlet)		Std Paint	Offshore Paint Opt-950S
Sensing Configuration & Accessory Options		CODE	
Standard: Internal Sensing, Exhaust to Main Valve Outlet		0	W
OPT 1: Internal Sensing, Exhaust to Atmosphere		1	V
OPT 2: Remote Sensing		2	T
OPT 3: Internal Sensing, with Manual Blowdown Valve		3	S
OPT 5: Internal Sensing, with Field Test Connection		5	R
OPT 6: Internal Sensing, with Rotometer to Purge Pilot Sense & Discharge Lines		6	P
OPT 7: Internal Sensing, Exhaust to Atmosphere with Rotometer to Purge Pilot Sense Line		7	M
OPT 8: Internal Sensing, Exhaust to Atmosphere with Field Test Connection		8	9
OPT A: Internal Sensing, Exhaust to Atmosphere with Manual Blowdown Valve		A	B

**\* For information on ATEX see pages 19 & 20 on the IOM.**

Алматы (7273)495-231  
Ангарск (3955)60-70-56  
Архангельск (8182)63-90-72  
Астрахань (8512)99-46-04  
Барнаул (3852)73-04-60  
Белгород (4722)40-23-64  
Благовещенск (4162)22-76-07  
Брянск (4832)59-03-52  
Владивосток (423)249-28-31  
Владикавказ (8672)28-90-48  
Владимир (4922)49-43-18  
Волгоград (844)278-03-48  
Вологда (8172)26-41-59  
Воронеж (473)204-51-73  
Екатеринбург (343)384-55-89

Иваново (4932)77-34-06  
Ижевск (3412)26-03-58  
Иркутск (395)279-98-46  
Казань (843)206-01-48  
Калининград (4012)72-03-81  
Калуга (4842)92-23-67  
Кемерово (3842)65-04-62  
Киров (8332)68-02-04  
Коломна (4966)23-41-49  
Кострома (4942)77-07-48  
Краснодар (861)203-40-90  
Красноярск (391)204-63-61  
Курск (4712)77-13-04  
Курган (3522)50-90-47  
Липецк (4742)52-20-81

Магнитогорск (3519)55-03-13  
Москва (495)268-04-70  
Мурманск (8152)59-64-93  
Набережные Челны (8552)20-53-41  
Нижний Новгород (831)429-08-12  
Новокузнецк (3843)20-46-81  
Новый Уренгой (383)227-86-73  
Новосибирск (383)232-86-73  
Омск (3812)21-46-40  
Орел (4862)44-53-42  
Оренбург (3532)37-68-04  
Пенза (8412)22-31-16  
Петрозаводск (8142)55-98-37  
Псков (8112)59-10-37  
Пермь (342)205-81-47

Ростов-на-Дону (863)308-18-15  
Рязань (4912)46-61-64  
Самара (846)206-03-16  
Санкт-Петербург (812)309-46-40  
Саратов (845)249-38-78  
Севастополь (8692)22-31-93  
Саранск (8342)22-96-24  
Симферополь (3652)67-13-56  
Смоленск (4812)29-41-54  
Сочи (862)225-72-31  
Ставрополь (8652)20-65-13  
Сургут (3462)77-98-35  
Сыктывкар (812)25-95-17  
Тамбов (4752)50-40-97  
Тверь (4822)63-31-35

Тольятти (8482)63-91-07  
Томск (3822)98-41-53  
Тула (4872)33-79-87  
Тюмень (3452)66-21-18  
Ульяновск (8422)24-23-59  
Улан-Удэ (3012)59-97-51  
Уфа (347)229-48-12  
Хабаровск (4212)92-98-04  
Чебоксары (8352)28-53-07  
Челябинск (351)202-03-61  
Череповец (8202)49-02-64  
Чита (3022)38-34-83  
Якутск (4112)23-90-97  
Ярославль (4852)69-52-93

Россия +7(495)268-04-70

Казахстан +7(7172)727-132

Киргизия +996(312)96-26-47