



## Model 4500 Spring Loaded Pressure Vent with Pipe-Away

### OBJECTIVE

The Model 4500 spring loaded pressure vent with pipe-away is intended for use where higher set pressures are required and the relieving vapors must be piped away and not emitted into the atmosphere. May also be used for in-line vacuum relief.

### TECHNIQUE

A spring loaded pallet allows for the discharge of vapors to the outlet piping when the tank pressure exceeds the pressure set point. Once the tank over pressure is relieved the spring loaded pallet closes providing a tight vapor seal. A flanged outlet connection is provided for easy pipe-away of vapors, eliminating their emission into the atmosphere and allowing compliance with applicable regulations.

### CONSTRUCTION

**Housing Material:** The Model 4500 vent is a rugged design made to last. Available in Aluminum, Carbon Steel, or 316 SST.

**Sizes - Connections.** Available in Sizes 2" through 6". CS and SST vents have Raised Face Flange, Aluminum vents have Flat Face Flange to mate with standard ASME 150# flange connections. On sizes 2" through 6", the Model 4500 is available with the same size inlet and outlet to reduce outlet piping cost.

**Pallet Diaphragm Material:** FEP TFE is Standard. Also available Buna-N, EPDM or Fluorocarbon Elastomer (FKM).

### SPECIAL FEATURES

**Modular.** The Model 4500 spring loaded pressure vent is part of the Valve Concepts, Inc. modular vent line. It is used in the assembly of the Model 3200, 4200, and 5200 pressure/vacuum vents with pipe away and the Model 3600 and the 4600 side mounted vacuum vent.

**Maintains Accurate Settings.** The minimum setting available is 1.25 psig. Maximum pressure setting is 15 psig. All vents are tested to Valve Concepts, Inc. high standard for leakage and set point prior to shipment. A certified test certificate is included with each vent verifying the accuracy. A leakage rate of less than 1 SCFH at 90% of customer specified set point is verified.

**Condensate Drainage.** Self-draining housing body and drip rings keep condensate away from seating surfaces, preventing freezing, binding and clogging.

**Air-Cushioned Seating.** Air-cushion seating provides tight sealing to reduce evaporation losses. The pallets have outer guiding and center stabilizing stem to provide self alignment and tight seating.

MATERIALS OF CONSTRUCTION		
Series	Housing	Pallet
4500CS	CS	316 SST
4500SST	316 SST	316 SST
4500A	Aluminum	316 SST

Алматы (7273)495-231  
Ангарск (3955)60-70-56  
Архангельск (8182)63-90-72  
Астрахань (8512)99-46-04  
Барнаул (3852)73-04-60  
Белгород (4722)40-23-64  
Благовещенск (4162)22-76-07  
Брянск (4832)59-03-52  
Владивосток (423)249-28-31  
Владикавказ (8672)28-90-48  
Владимир (4922)49-43-18  
Волгоград (844)278-03-48  
Вологда (8172)26-41-59  
Воронеж (473)204-51-73  
Екатеринбург (343)384-55-89

Иваново (4932)77-34-06  
Ижевск (3412)26-03-58  
Иркутск (395)279-98-46  
Казань (843)206-01-48  
Калининград (4012)72-03-81  
Калуга (4842)92-23-67  
Кемерово (3842)65-04-62  
Киров (8332)68-02-04  
Колмна (4966)23-41-49  
Кострома (4942)77-07-48  
Краснодар (861)203-40-90  
Красноярск (391)204-63-61  
Курск (4712)77-13-04  
Курган (3522)50-90-47  
Липецк (4742)52-20-81

Магнитогорск (3519)55-03-13  
Москва (495)268-04-70  
Мурманск (8152)59-64-93  
Набережные Челны (8552)20-53-41  
Нижний Новгород (831)429-08-12  
Новокузнецк (3843)20-46-81  
Ноябрьск (3496)41-32-12  
Новосибирск (383)227-86-73  
Омск (3812)21-46-40  
Орел (4862)44-53-42  
Оренбург (3532)37-68-04  
Пенза (8412)22-31-16  
Петрозаводск (8142)55-98-37  
Псков (8112)59-10-37  
Пермь (342)205-81-47

Ростов-на-Дону (863)308-18-15  
Рязань (4912)46-61-84  
Самара (846)206-03-16  
Санкт-Петербург (812)309-46-40  
Саратов (845)249-38-78  
Севастополь (8692)22-31-93  
Саранск (8342)22-96-24  
Симферополь (3652)67-13-56  
Смоленск (4812)29-41-54  
Сочи (862)225-72-31  
Ставрополь (8652)20-65-13  
Сургут (3462)77-98-35  
Сыктывкар (8212)25-95-17  
Тамбов (4752)50-40-97  
Тверь (4822)63-31-35

Тольятти (8482)63-91-07  
Томск (3822)98-41-53  
Тула (4872)33-79-87  
Тюмень (3452)66-21-18  
Ульяновск (8422)24-23-59  
Улан-Удэ (3012)59-97-51  
Уфа (347)229-48-12  
Хабаровск (4212)92-98-04  
Чебоксары (8352)28-53-07  
Челябинск (351)202-03-61  
Череповец (8202)49-02-64  
Чита (3022)38-34-83  
Якутск (4112)23-90-97  
Ярославль (4852)69-52-93

Россия +7(495)268-04-70

Казахстан +7(7172)727-132

Киргизия +996(312)96-26-47

## STANDARD/GENERAL SPECIFICATIONS

**Gaskets:** Standard: TFE/TFE Rope

**Painting:** Standard: Exterior coating will be a combination of Cashco Paint Specs #S-1777 epoxy and #S-1743 powder coated. Fasteners, seat surfaces and corrosion resistant parts excluded.

**Diaphragm**  
**Temperature**  
**Limits:**

FEP-TFE:  
-400° to 400° F (-240° to 204°C)  
Fluorocarbon Elastomer – (FKM):  
-20° to 400° F (-28° to 204°C)  
Buna-N (Nitrile-NBR):  
-30° to 200° F (-34° to 93°C)  
EPDM (Ethylene propylene):  
-40° to 225° F (-40° to 107°C)

## DIMENSIONS

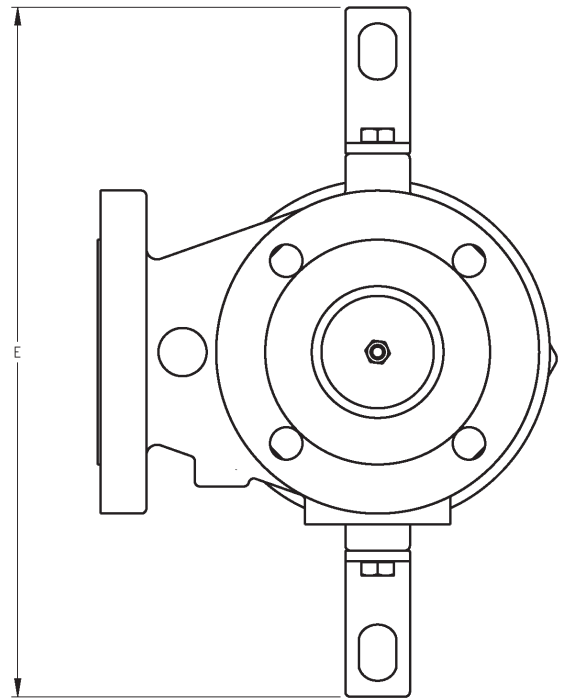
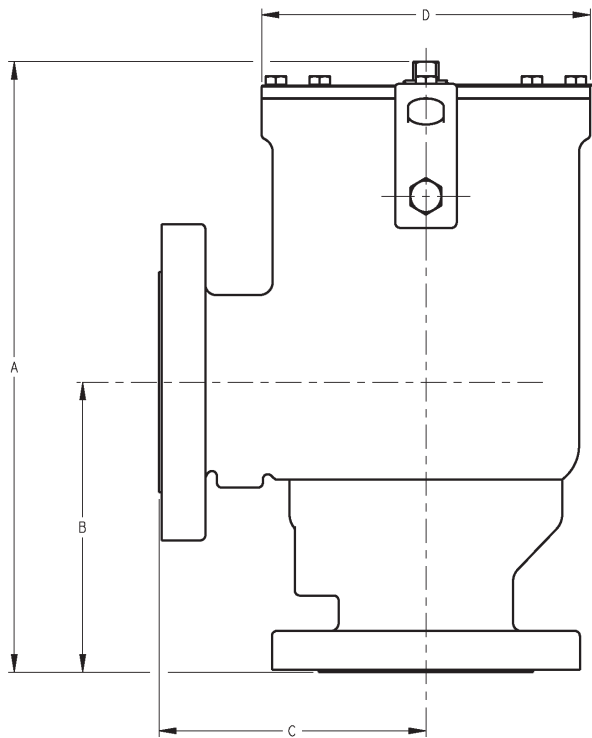

ENGLISH Units - in Aluminum, Carbon Steel & Stainless Steel Body						Weight lbs.	
SIZE In	A	B	C	D (diam.)	E	Alum	CS/SST
2" x 2"	12.34"	5.71"	6.00"	7.28"	15.16"	21	55
2" x 3"	12.34"	6.26"	6.19"	7.28"	15.19"	22	60
3" x 3"	14.48"	6.91"	6.50"	8.12"	16.00"	28	76
3" x 4"	14.48"	7.41"	6.50"	8.12"	16.00"	29	80
4" x 4"	16.97"	8.78"	8.00"	10.88"	18.62"	44	123
4" x 6"	16.97"	9.78"	8.00"	10.88"	18.62"	46	128
6" x 6"	18.21"	10.34"	9.00"	12.51"	20.84"	64	178
6" x 8"	18.59"	11.53"	9.00"	12.51"	20.84"	68	191

METRIC Units - (mm) Aluminum, Carbon Steel & Stainless Steel Body						Weight kg.	
SIZE (DN)	A	B	C	D (diam.)	E	Alum	CS/SST
(50) x (50)	313	145	152	185	385	10	25
(50) x (80)	313	159	157	185	385	10	27
(80) x (80)	368	176	165	206	406	13	34
(80) x (100)	368	188	165	206	406	13	36
(100) x (100)	431	223	203	276	473	20	56
(100) x (150)	431	248	203	276	473	21	58
(150) x (150)	462	263	229	318	529	29	81
(150) x (200)	472	293	229	318	529	31	87

The contents of this publication are presented for informational purposes only, and while every effort has been made to ensure their accuracy, they are not to be construed as warranties or guarantees, express or implied, regarding the products or services described herein or their use or applicability. We reserve the right to modify or improve the designs or specifications of such product at any time without notice.

Cashco, Inc. does not assume responsibility for the selection, use or maintenance of any product. Responsibility for proper selection, use and maintenance of any Cashco, Inc. product remains solely with the purchaser.

# 4500 Series PRODUCT CODE

02/07/20

Last 6 Characters reserved for SPQ drawing numbers assigned by Cashco Inc.  
(Format as - # # # # # #)



POSITION 3 - FLANGE - INLET SIZE			
ASME INCH	CODE	DIN FLANGE DN (rating)	CODE
2"	2	50 (PN16)	H
3"	3	80 (PN16)	J
4"	4	100 (PN16)	K
6"	6	150 (PN16)	L

POSITION 4 - FLANGE - OUTLET SIZE			
ASME INCH	CODE	DIN FLANGE DN(rating)	CODE
2"	2	50 (PN16)	H
3"	3	80 (PN16)	J
4"	4	100 (PN16)	K
6"	6	150 (PN16)	L
8"	8	200 (PN10)	M
		200 (PN16)	T

POSITION 5 - BODY / TRIM MATERIALS		
MATERIAL	W/O Flame-screen	W/ Flame-screen
	CODE	CODE
ALUM/SST	A	B
CS/SST	C	D
SST/SST	S	T

POSITION 7 - DIAPHRAGM MATERIALS	
DIAPHRAGM	CODE
FEP TFE (Std.)	A
Buna-N	B
EPDM	D
FKM	F

POSITION 8 - PRESSURE SET POINT		
Spring Loaded Range		CODE
psig	barg	
1.25 - 4	.08 - .27	2
> 4 - 6	> .27 - .41	3
> 6 - 8	> .41 - .55	4
> 8 - 10	> .55 - .68	5
> 10 - 12	> .68 - .83	6
> 12 - 13	> .83 - .89	7
> 13 - 15	> .89 - 1.03	8

Алматы (7273)495-231  
Ангарск (3955)60-70-56  
Архангельск (8182)63-90-72  
Астрахань (8512)99-46-04  
Барнаул (3852)73-04-60  
Белгород (4722)40-23-64  
Благовещенск (4162)22-76-07  
Брянск (4832)59-03-52  
Владивосток (423)249-28-31  
Владикавказ (8672)28-90-48  
Владимир (4922)49-43-18  
Волгоград (844)278-03-48  
Волгодда (812)26-41-59  
Воронеж (473)204-51-73  
Екатеринбург (343)384-55-89

Иваново (4932)77-34-06  
Ижевск (3412)26-03-58  
Иркутск (395)279-98-46  
Казань (843)206-01-48  
Калининград (4012)72-03-81  
Калуга (4842)92-23-67  
Кемерово (3642)65-04-62  
Киров (8332)68-02-04  
Коломна (4966)23-41-49  
Кострома (4942)77-07-48  
Краснодар (861)203-40-90  
Красноярск (391)204-63-61  
Курск (4712)77-13-04  
Курган (3522)50-90-47  
Липецк (4742)52-20-81

Магнитогорск (3519)55-03-13  
Москва (495)268-04-70  
Мурманск (8152)59-64-93  
Набережные Челны (8552)20-53-41  
Нижегород (831)429-08-12  
Новокузнецк (3843)20-46-81  
Новосибирск (3496)41-32-12  
Новосибирск (393)227-86-73  
Омск (3812)21-46-40  
Орел (4862)44-53-42  
Оренбург (3532)37-68-04  
Пенза (8412)22-31-16  
Петрозаводск (8142)55-98-37  
Псков (8112)59-10-37  
Пермь (342)205-81-47

Ростов-на-Дону (863)308-18-15  
Рязань (4912)46-61-64  
Самара (846)206-03-16  
Санкт-Петербург (812)309-46-40  
Саратов (845)249-38-78  
Севастополь (8692)22-31-93  
Саранск (8342)22-96-24  
Симферополь (3652)67-13-56  
Смоленск (4812)29-41-54  
Сочи (862)225-72-31  
Ставрополь (8652)20-65-13  
Сургут (3462)77-98-35  
Сыктывкар (8212)25-95-17  
Тамбов (4752)50-40-97  
Тверь (4822)63-31-35

Тольятти (8482)63-91-07  
Томск (3822)98-41-53  
Тула (4872)33-79-87  
Тюмень (3452)66-21-18  
Ульяновск (8422)24-23-59  
Улан-Удэ (3012)59-97-51  
Уфа (347)229-48-12  
Хабаровск (4212)92-98-04  
Чебоксары (8352)28-53-07  
Челябинск (351)202-03-61  
Череповец (8202)49-02-64  
Чита (3022)38-34-83  
Якутск (4112)23-90-97  
Ярославль (4852)69-52-93

Россия +7(495)268-04-70

Казахстан +7(7172)727-132

Киргизия +996(312)96-26-47

<https://cashco.nt-rt.ru/> || [coc@nt-rt.ru](mailto:coc@nt-rt.ru)