



ISO Registered Company

MODEL 988-MB

METALLIC BELLOWS STEM SEAL FOR MODEL 988 CONTROL VALVE IN CHEMICAL SERVICE



Bellows-Stem Sub-Assembly

OVERVIEW

The Cashco Model 988-MB is a variation of the basic Cashco Model 988 globe-style control valve that incorporates a metallic bellows stem seal. The purpose of the design is to maximize the reduction of fugitive emissions of hazardous fluids in the chemical industry from one of the most common sources – conventional control valve stem packing.

The bellows is designed conservatively, in that there are a relatively large number of convolutions to keep bellows internal stresses to the lowest practical levels, optimizing expected cycle life, and minimizing effects of bellows “snaking”.

FEATURES

- Designed for providing long service life where environmental and personnel protection are of primary importance.
- 70K–250K average stroke cycle life at 200 psig and 200°F (13.8 Barg and 94°C).
- External pressure loading to reduce “snaking” and optimize location of convolution stresses.
- Anti-rotation stop to prevent undesired bellows rotational forces.
- Sufficient number of convolutions to provide full design stroke.
- Live-loaded secondary stem packing seal.
- Leak-off connection with slotted plug; for use in alerting of bellows leakage.
- Designed with bellows “neutral zone” at optimum position for longest life.
- Two bellows materials – 316L and Hastelloy C – to cover majority of corrosive fluids.



LINE SIZES AVAILABLE

3/4" (DN20), 1" (DN25), 1-1/2" (DN40), 2" (DN50)



END CONNECTIONS

NPT, FLANGED, SOCKET WELD



COMMON APPLICATIONS

FLUIDS THAT ARE CLASSIFIED AS “ENVIRONMENTALLY HAZARDOUS”, BUT ARE NOT “AGGRESSIVELY CORROSIVE” TO THE BELLOWS MATERIAL



DESIGN PRESSURE

INLET & MAXIMUM PRESSURE DROP: UP TO 200 psig (13.8 Barg)

Алматы (7273)495-231
 Ангарск (3955)60-70-56
 Архангельск (8182)63-90-72
 Астрахань (8512)99-46-04
 Барнаул (3852)73-04-60
 Белгород (4722)40-23-64
 Благовещенск (4162)22-76-07
 Брянск (4832)59-03-52
 Владивосток (423)249-28-31
 Владикавказ (8672)28-90-48
 Владимир (4922)49-43-18
 Волгоград (844)278-03-48
 Вологда (8172)26-41-59
 Воронеж (473)204-51-73
 Екатеринбург (343)384-55-89

Иваново (4932)77-34-06
 Ижевск (3412)26-03-58
 Иркутск (395)279-98-46
 Казань (843)206-01-48
 Калининград (4012)72-03-81
 Калуга (4842)92-23-67
 Кемерово (3842)65-04-62
 Киров (8332)68-02-04
 Копомна (4966)23-41-49
 Кострома (4942)77-07-48
 Краснодар (861)203-40-90
 Красноярск (391)204-63-61
 Курск (4712)77-13-04
 Курган (3522)50-90-47
 Липецк (4742)52-20-81

Магнитогорск (3519)55-03-13
 Москва (495)268-04-70
 Мурманск (8152)59-64-93
 Набережные Челны (8552)20-53-41
 Нижний Новгород (831)429-08-12
 Новокузнецк (3843)20-46-81
 Ноябрьск (3496)41-32-12
 Новосибирск (383)227-86-73
 Омск (3812)21-46-40
 Орел (4862)44-53-42
 Оренбург (3532)37-68-04
 Пенза (8412)22-31-16
 Петрозаводск (8142)55-98-37
 Псков (8112)59-10-37
 Пермь (342)205-81-47

Ростов-на-Дону (863)308-18-15
 Рязань (4912)46-61-64
 Самара (846)206-03-16
 Санкт-Петербург (812)309-46-40
 Саратов (845)249-38-78
 Севастополь (8692)22-31-93
 Саранск (8342)22-96-24
 Симферополь (3652)67-13-56
 Смоленск (4812)29-41-54
 Сочи (862)225-72-31
 Ставрополь (8652)20-65-13
 Сургут (3462)77-98-35
 Сыктывкар (8212)25-95-17
 Тамбов (4752)50-40-97
 Тверь (4822)63-31-35

Тольятти (8482)63-91-07
 Томск (3822)98-41-53
 Тула (4872)33-79-87
 Тюмень (3452)66-21-18
 Ульяновск (8422)24-23-59
 Улан-Удэ (3012)59-97-51
 Уфа (347)229-48-12
 Хабаровск (4212)92-98-04
 Чебоксары (8352)28-53-07
 Челябинск (351)202-03-61
 Череповец (8202)49-02-64
 Чита (3022)38-34-83
 Якутск (4112)23-90-97
 Ярославль (4852)69-52-93

Россия +7(495)268-04-70

Казахстан +7(7172)727-132

Киргизия +996(312)96-26-47

TECHNICAL INFORMATION CLARIFICATION

The Model 988-MB is a variation of Cashco’s Model 988 standard, globe-style, control valve. From the lower bonnet-to-body flange downwards through the body portion of the Model 988-MB, it is identical to the Model 988. Though the bonnet, bellows-stem assembly, and stub-stem/plug assembly themselves are unique for the Model 988-MB, all other portions of the body sub-assembly within and above the bonnet, are the same as the Model 988 with standard live-loaded packing. The actuator design is similar to that of the family of actuators — Models C27 and C53 — utilized on the Model 521 TFE control valve, which includes a swivel connector to join the actuator and body stems.

Only that portion of technical information that is unique with the Model 988-MB and different from corresponding information for Model 988, is indicated herein. All other technical information present in Model 988-TB, but not indicated in Model 988-MB-TB, is the same.

GENERAL SPECIFICATIONS

Body Pressure/ Temperature Rating:	Body and bonnet wall thicknesses meet ANSI B16.34 requirements for 150# or 300# for cast carbon steel (CS) or cast stainless steel (SST). Actual pressure vs. temperature limits are reduced due to incorporation of metal bellows seal. See Table 1 and Graphs 1 and 2.	Cycle Life:	Dependent upon actual pressure, temperature, stroke length and bellows material. See Graphs 1 and 2.
Inlet Pressure Range:	Full vacuum up to 200 psig (13.8 Barg) – all materials.	Max. Pressure Drop:	Up to 200 psid (13.8 Bard). See Tables 2 and 3.
Working Temperature Range:	-20 to +450°F (-29 to +232°C).	Leakage Testing:	Each fabricated bellows helium (He) leakage tested to 10 ⁻⁶ cc/sec level maximum. Assembled body sub-assembly shop hydro-leak tested to 300 psig (20.7 Barg) per ANSI B16.34.

BODY SUB-ASSEMBLY SPECIFICATIONS

Body/Bellows Column/ Bonnet Material Combinations:	CS/SST/SST; SST/SST/SST; H-C/H-C/H-C. CS – ASTM A216, Gr. WCB. SST – ASTM A351, Gr. CF3M (316L). H-C – ASTM A494, Gr. CW-12MW (similar to Hastelloy C).
Bellows-Stem Assembly:	Formed from flat strip. Longitudinal resistance welded. Single-ply construction; 0.006" (0.152 mm) wall thickness. Bellows resistance welded to bonnet adapter at top, bellows-stem at bottom; see Figure 2.
Bellows-Stem Assembly Materials:	<u>SST Construction</u> – Type 316L. <u>Hastelloy Construction</u> – Allow C-22.

**Trim
Combinations:**

Seat Design	Trim Desig. No.	Materials				Basic Trim Descript.
		Body	Bellows Column & Bonnet	Bellows Stem Assy.	Trim	
Metal	S1R, S1S	CS or SST	SST	SST	316SST	316SST
	HS1R, HS1S	CS or SST	SST	H-C	316SST	SST + H-C
	HS2R	CS or SST	SST	H-C	H-C	SST + H-C
	HC1	H-C	H-C	H-C	H-C	H-C
Comp Seat	S3R, S3S	CS or SST	SST	SST	316SST	316SST/TFE
	HS3R, HS3S	CS or sST	SST	H-C	316SST	SST+CS/TFE
	HC3	H-C	H-C	H-C	H-C	H-C/TFE

See Table 6 for complete trim material specifications.

Secondary Stem Packing Design: TFE V-ring (no lubricating agent). Live-loaded via coiled spring.

(No grafoil or high temperature alternate packing offered. No dual packing ring designs offered; i.e. no Opt-34 arrangements.)

Leak-Off Connection: 1/4" NPT tapped opening on bonnet. Complete with removable SST or Hast. C plug. See Figure 1.

Slotted Leak-Off Plug Materials: 316 SST with SST bonnet; Hast. C-276 with CW-12MW bonnet.

Materials: Swivel-type stem connector – SST.

OPTION SPECIFICATIONS

Option-15: STELLITED TRIM. Stellite seats offered for trim designation numbers S1R, S1S, HS1R and HS1S.

Option-34: DUAL PACKING. These options are not available for Model 988-MB.

Option-40: NACE SERVICE. This option is not available for Model 988-MB.

Option-94: HELIUM LEAK TEST. Unit is factory helium leak tested and certified per Cashco testing specification #S-1591.

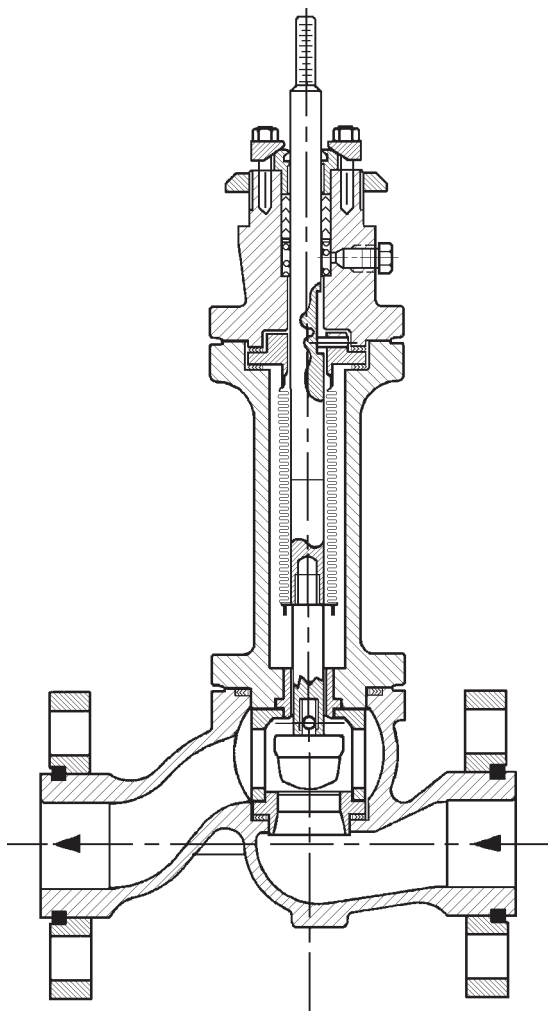

FIGURE 1

Model 988-MB Body Assembly Cutaway

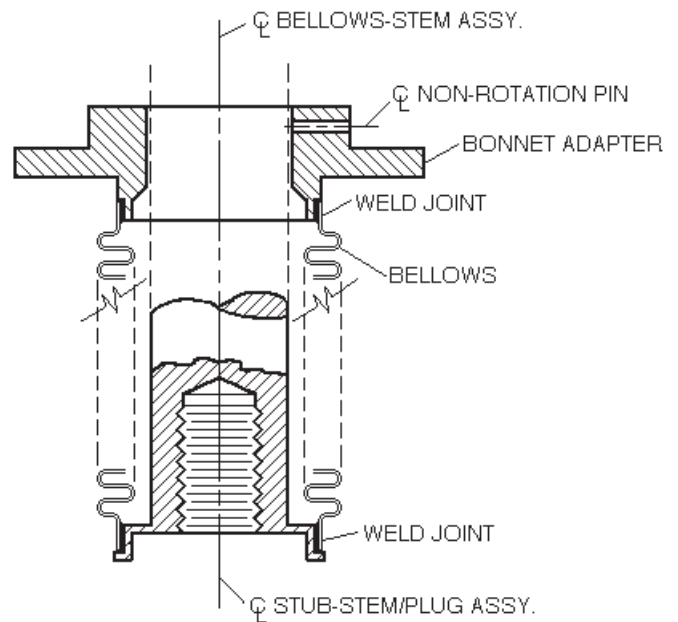

FIGURE 2

Bellows-Stem Assembly

TECHNICAL SPECIFICATIONS

TABLE 1 MATERIAL PRESSURE / TEMPERATURE RATINGS						
Body / Bellows Column/ Bonnet Material		End Connection	English Units		Metric Units	
General	ASTM Specifications		Pressure (psig)	Temperature (°F)	Pressure (Barg)	Temperature (°C)
CS/SST/SST	A216, Gr. WCB & A351, Gr. CF3M	All (NOTE 1)	200	-20 to +450	(13.8)	(-29 to +232)
SST/SST/SST	A351, Gr. CF3M	All (NOTE 2)	200	-20 to +450	(13.8)	(-29 to +232)
H-C/H-C/H-C	A494, Gr. CW-12MW (NOTE 3)	All (NOTE 2)	200	-20 to +450	(13.8)	(-29 to +232)

NOTE 1: CS separable flanges with CS body.
NOTE 2: CS or SST separable flanges with SST or H-C body.
NOTE 3: HC-material recognized by ASME, Section VIII of BPVC; not covered by ANSI B16.34. Wall thicknesses of H-C bodied units in agreement with general intent of ANSI B16.34.

TABLE 2 MAXIMUM PRESSURE DROP - PSID (BARD) CLASS IV SEAT LEAKAGE FOR METAL SEATED; CLASS VI SEAT LEAKAGE FOR COMPOSITION SEATED													
LINE SIZE	PORT SIZE	ORIFICE SIZE		ACTUATOR			DIRECT ATO-FC & REVERSE ATC-FO						
				MODEL NO.	BENCH RANGE		METAL SEAT		COMP SEAT				
		INCH	(mm)		PSIG	(BARG)	PSID	(BARD)	PSID	(BARD)			
3/4" - 1" (DN25)	FULL	0.750	(19.1)	C27	5-15	(0.34-1.03)	131	(9.0)	200	(13.8)			
					15-60	(1.03-4.14)	200	(13.8)	200	(13.8)			
	1-STEP & 2-STEP	0.562	(14.3)	C27	5-15	(0.34-1.03)	200	(13.8)	200	(13.8)			
					15-50	(1.03-4.14)	200	(13.8)	200	(13.8)			
1-1/2" (DN40)	FULL	1.250	(31.8)	C27	5-15	(0.34-1.03)	N/A	N/A	60	(4.1)			
					15-60	(1.03-4.14)	200	(13.8)	200	(13.8)			
				C53	5-15	(0.34-1.03)	77	(5.3)	141	(9.7)			
					15-60	(1.03-4.14)	200	(13.8)	200	(13.8)			
	REDUCED	0.750	(19.1)	C27	5-15	(0.34-1.03)	131	(9.0)	200	(13.8)			
					15-60	(1.03-4.14)	200	(13.8)	200	(13.8)			
2" (DN50)	FULL	1.875	(47.6)	C27	15-60	(1.03-4.14)	80	(5.5)	122	CF			
					C53	5-15	(0.34-1.03)	CF	CF	CF	CF		
				C110		15-60	(1.03-4.14)	188	(13.0)	200	(13.8)		
					5-15	(0.34-1.03)	104	(7.2)	147	(10.1)			
				REDUCED	1.000	(25.4)	C27	15-60	(1.03-4.14)	200	(13.8)	200	(13.8)
								C53	5-15	(0.34-1.03)	161	(11.1)	200
	C110	15-60	(1.03-4.14)	200	(13.8)	N/A	N/A						
		5-15	(0.34-1.03)	200	(13.8)	200	(13.8)						

1) CF = Consult Factory where seat leakage requirements may not meet Cashco S-1597.
2) Excessive differential pressures have been derated to a maximum of 200 psid (13.8 barg) corresponding with limitation of the bellows. Further derating may be necessary based on valve body pressure/temperature ratings.
3) ATC-FO values for 5-15 psig bench range based on maximum 20 psig (1.4 barg) supply pressure and requires use of a positioner. ATC-FO values for 15-60 psig bench range based on maximum 75 psig (5.2 barg) supply pressure and requires use of a positioner.

TABLE 3 AND TABLE 4 IN 988-TB DO NOT APPLY TO MODEL 988-MB

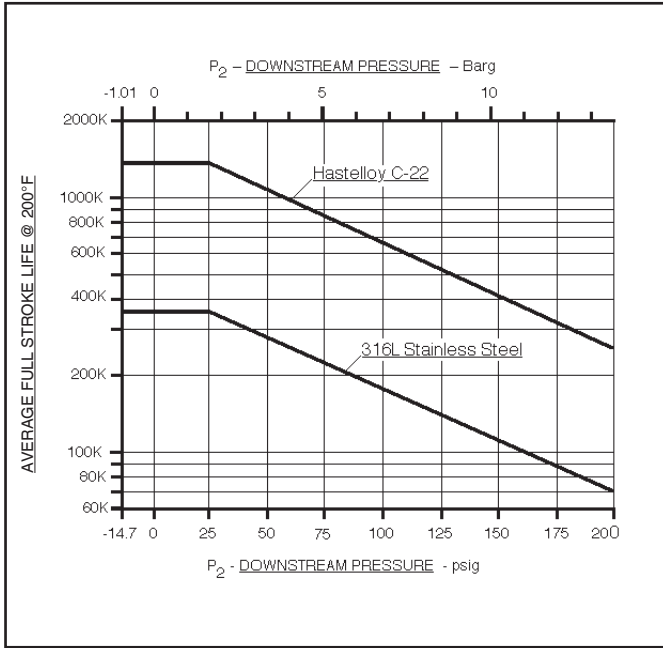

GRAPH NO. 1

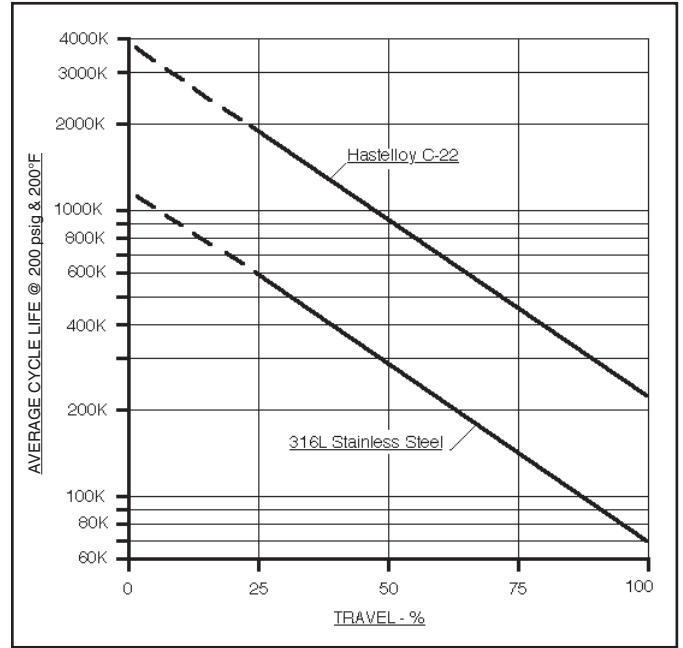

GRAPH NO. 2

TABLE 5
TRIM MATERIALS vs. DESIGNATION NUMBERS

Description	TRIM DESIGNATION NO. – METAL SEATED					
	S1R *	S1S *	HC1	HS1R *	HS1S *	HS2R
Stub-Stem/Plug Assy.	316L SST	316L SST	Hast C-276	316L SST	316L SST	Hast C-276
Seat Ring	316L SST	316L SST	Hast C-276	316L SST	316L SST	Hast C-276
Cage	CF3M	CF3M	CW-12MW	CF3M	CF3M	CW-12MW
Upper Stem Guide	Rulon Tape	Rulon Tape	Rulon Tape	Rulon Tape	Rulon Tape	Rulon Tape
Lower Guide Bushing	316 SST Rulon	Stellite #6	Hast C-276 Rulon	316 SST Rulon	Stellite #6	316 SST Rulon
Packing Load Spring	Cold Worked 316 SST	Cold Worked 316 SST	Cold Worked Hast C-276	Cold Worked Hast C-276	Cold Worked Hast C-276	Cold Worked Hast C-276
Packing Follower	316 SST	316 SST	Hast C-276	316 SST	316 SST	316 SST
Wiper Ring	**	**	**	**	**	**
Bellows-Stem Assy.	316L SST	316L SST	Hast C-276 Hast C-22	Hast C-276 Hast C-22	Hast C-276 Hast C-22	Hast C-276 Hast C-22
Anti-Rotation Pin	316 SST	316 SST	Hast C-276	316 SST	316 SST	316 SST
Description	TRIM DESIGNATION NO. – COMPOSITION / SOFT SEATED					
	S3R	S3S	HC3	HS3R	HS3S	
Stub-Stem/Plug Assy.	316L SST	316L SST	Hast C-276	316L SST	316L SST	X
Seat Ring	316L SST	316L SST	Hast C-276	316L SST	316L SST	
Cage	CF3M	CF3M	CW-12MW	CF3M	CF3M	
Upper Stem Guide	Rulon Tape	Rulon Tape	Rulon Tape	Rulon Tape	Rulon Tape	
Lower Guide Bushing	316 SST Rulon	Stellite #6	Hast C-276 Rulon	316 SST Rulon	Stellite #6	
Packing Load Spring	Cold Worked 316 SST	Cold Worked 316 SST	Cold Worked Hast C-276	Cold Worked Hast C-276	Cold Worked Hast C-276	
Packing Follower	316 SST	316 SST	Hast C-276	316 SST	316 SST	
Wiper Ring	**	**	**	**	**	
Seat Retainer	316 SST	316 SST	Hast C-276	316 SST	316 SST	
Seat Insert	TFE	TFE	TFE	TFE	TFE	
Bellows-Stem Assy.	316L SST	316L SST	Hast C-276 Hast C-22	Hast C-276 Hast C-22	Hast C-276 Hast C-22	
Anti-Rotation Pin	316 SST	316 SST	Hast C-276	316 SST	316 SST	

* Use these trim designation numbers for Option-15 Stellite Seating Surfaces.

** Polyurethane / Molybdenum.

Material	Material Specifications
316 SST	ASTM A479, S31600; Wrought Barstock, Annealed
316L SST	ASTM A479, S31603; Wrought Barstock, Annealed
Hastelloy C-276	ASTM B574, Alloy N10276; Wrought Barstock, Annealed
CF8M	ASTM A351, Gr. CF8M; Cast 316 SST
CW-12MW	ASTM A494, Gr. CW-12MW; Cast Ni-Mo-Cr, similar to "Hastelloy C"

DIMENSIONS & WEIGHTS

ENGLISH UNITS – inch & lbs.			
Dimensions	Body Size		
	3/4" & 1"	1-1/2"	2"
A	12.48	12.84	16.24
B **	21.95	22.31	25.72
C ***	25.19	25.55	28.96
D	Model C27 Act. = 9.00 / Model C53 Act. = 11.56		
E	Model C27 Act. = 9.97 / Model C53 Act. = 11.21		
F	1.28	1.80	2.09
G ¹ NPT or SW	8.25	9.25	11.25
G ² Flanged *	8.50	9.50	11.50
H ¹	3.68	4.00	5.00
H ² Flanged	3.81	4.12	5.12
Wt. w C27 ****	26	30	42
Wt. w C53 ****	36	40	52

METRIC UNITS – mm & kgs.			
Dimensions	Body Size		
	DN20 & 25	DN40	DN50
A	317.0	326.1	412.5
B **	557.5	566.7	653.3
C ***	639.8	649.0	735.6
D	Model C27 Act. = 228.6 / Model C53 Act. = 293.6		
E	Model C27 Act. = 253.1 / Model C53 Act. = 284.7		
F	32.5	45.7	53.1
G ¹ NPT or SW	209.6	235.0	285.75
G ² Flanged *	215.9	241.3	292.1
H ¹	93.5	101.6	127.0
H ² Flanged	96.8	104.6	130.0
Wt. w C27 ****	11.8	13.6	19.0
Wt. w C53 ****	16.3	18.1	23.5

* Face-to-face dimensions per ISA 75.08.07.

** "B" dim for C53 Actuator add 0.14" (3.5mm).

*** "C" dim for C53 Actuator add 0.92" (23.4mm).

**** NPT Basic valve w/actuator weight, no accessories. Add 4lbs. (1.8kg) for positioner, Add 3 lbs (1.4kg) for limit switch, Add 15 lbs (6.8kg) for handwheel operator.

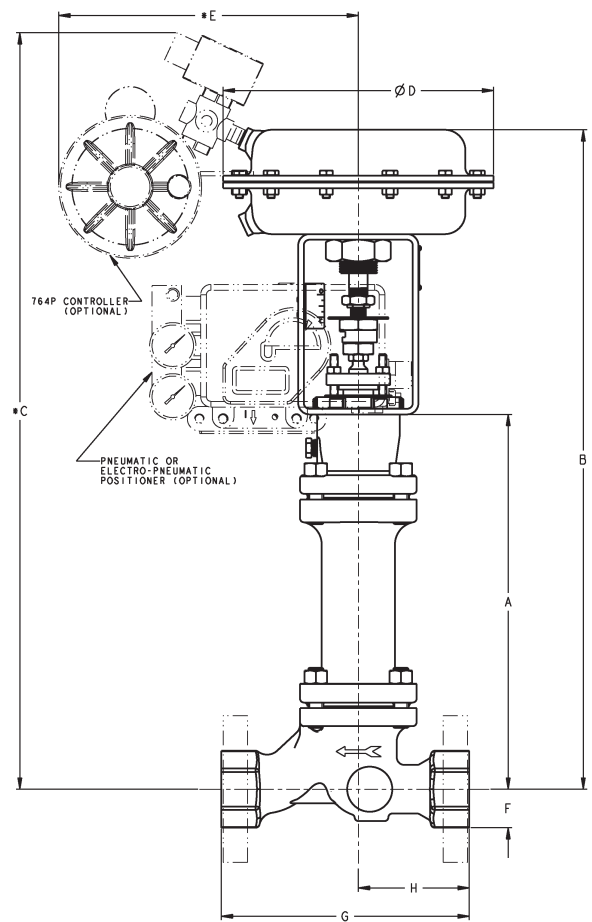

MODEL 988MB PRODUCT CODER 12/02/20

An "X" in POS 12 followed by a 5-digit control number overrides remaining selections.

87	POS 3	—	POS 5	POS 6	POS 7	7	—	0	POS 11	POS 12	POS 13	POS 14	POS 15	POS 16	POS 17	C
----	-------	---	-------	-------	-------	---	---	---	--------	--------	--------	--------	--------	--------	--------	---

POSITION 3 - SIZE & BODY MATERIAL				
Size		Body Material		
In	(DN)	CS	SST	H-C
CODE	CODE	CODE	CODE	CODE
3/4"	(20)	A	R	H
1"	(25)	B	S	L
1-1/2"	(40)	D	U	J
2"	(50)	E	V	K

POSITION 5 - END CONNECTIONS				
Body Material	End Connection		Split Rings	
	Flanged		CS	SST
	Press. Cl.	Material	CODE	CODE
CS, SST, & H-C	150 #	CS	3	A
	300 #	CS	4	B
	PN 40	CS	7	E
SST & H-C	150 #	SST		C
	300 #	SST		D
	PN 40	SST		F
	End Connection		CODE	
CS & SST	NPT - Screwed		1	
	SW - Socketweld		2	

POSITION 6 - TRIM MATERIAL			
Metal Seated		Composition/Soft Seated	
Designation No.	CODE	Designation No.	CODE
S1S	A	S3S	E
S1R *	B	S3R	F
HS1S	J	HS3S	M
HS1R	K	HS3R	N
HS2R	L		
HC1	D	HC3	H

* Base (Std) Trim

POSITION 7 - PORT SIZE					
Trim Character	Option	Available Seat Design		Port Size	Flow Direction Std. - FTO *
		Metal	Soft		
=%	None	All	All	Full	A
				1-Step Reduced	B
				2-Step Reduced	E **
Linear	None	All	All	Full	C
				1-Step Reduced	D
				2-Step Reduced	G **
=%	-15 Stellite	HS1R, HS1S, S1R or S1S only	None	Full	M
				1-Step Reduced	N
				2-Step Reduced	T **
Linear	-15 Stellite	HS1R, HS1S, S1R or S1S only	None	Full	P
				1-Step Reduced	R
				2-Step Reduced	V **

POSITION 11 - ACTUATOR MODEL / BENCH SET RANGE & ACTION				
Model	5-15 psig		15-60 psig	
	ATO FC	ATC FO	ATO FC	ATC FO
C27	A	1	B	2
C53	3	5	4	6
No Act. Body Assy only	0			

* Refer back to TB - Max. Pressure Drop Table 2 to confirm selection of Act. Model with Port size in Position 7.

POSITION 12 - 764P * (Bracket Mounted) - AIRSET (Bracket Mounted) - SOLENOID VALVE			
764P / Action	Solenoid Valve *** Exhaust on Deenergization		
	None	120VAC 60 Hz	24 VDC
None	CODE		
	0	6	C
Reverse **	2	8	E
Reverse W/ Airset **	3	9	F
Direct **	4	A	G
Direct W/ Airset **	5	B	H
Special Construction Contat Cashco for Code	X		

* Refer to 764-TB for Product Code of Controller.
** Select Code 1 on Position 13 if positioner is needed.
*** Solenoid rated as 4/4X only.

* Reverse - FTC is NOT recommended.
** Not available on 1-1/2" and 2" sizes.

POSITION 13 - DIRECT ACTING POSITIONER with AIRSET (Bracket Mounted) (3-15 psig) 4-20 mA Specify Split Range in Special Instructions on the P.O.					
Positioner Model	Ratings	Analog/Digital	Hart	Fieldbus	Profibus
P5 P/P *	Gen. Purpose	1			
D20 D I/P	Gen. Purpose	C	D		
D20 A I/P * ‡	Intrinsically Safe	2	5		
D20 E I/P *** ‡	Explosion Proof	E	F		
D3 X I/P	Gen. Purpose	L	M	N	P
D3 I I/P	Intrinsically Safe	3	6	8	A
D3 E I/P **** ‡	Explosion Proof	G	H	J	K
PS2-1 I/P	Gen. Purpose	Q	R	S	T
PS2-2 I/P	Intrinsically Safe	&	7	9	B
PS2-3 I/P ***	Explosion Proof	<	U	V	W
None **		0			

* Stock Item
** Actuator Assembly includes dimensions for (Namur) Mounting per IEC 60534-6-1.
*** D20E & PS2-3 are not available with limit/proximity switch option. Select codes "8", "9" or "0" in Pos. 15.
**** D3E Positioner is not available with options. Please select code "0" in Pos. 15.
‡ PMV Positioners are not FM Approved at this time. If you need FM Approval, please specify the Siemens PS2.

POSITION 14 - GAUGE BLOCK	
Option for Positioner	Code
None *	0
Gauge Block **	1

* For P5 gauge ports built in. No gauges.
* For D20 E, D3 E & PS2-3 gauge block is standard. No gauges.
** For D20 D, D20E & D20 A and PS2-1 & PS2-2 - gauge block with gauges.
** For D3 X & D3 I gauge block only - no gauges.

POSITION 15 - POSITIONER OPTIONS							
Options	POSITIONERS			I/P TRANSDUCERS *			
	1 Inductive Limit Switches	1 Micro-switches Limit Switches	Position Transmitter	3-15 PSIG No Airset **	3-15 PSIG W/ Airset **	0-60 PSIG No Airset ***	0-60 PSIG W/ Airset ***
CODE							
P5				4	5		
D3 & D20 ²	7	T	9				
PS2			8				
No Positioner				C	F	R	S
None	0						

* For 0-60 Psig Transducer please contact the factory.
** If 5-15 psig Bench Range is selected in Pos. 11, codes R & S are invalid options.
*** If 15-60 psig Bench Range is selected in Pos. 11, codes 4, 5, C & F are invalid options.
¹ D20E & PS2-3 are not available with limit/proximity switch option. Select codes "8", "9" or "0".
² D3E Positioner is not available with options. Please select code "0".

Алматы (7273)495-231
Ангарск (3955)60-70-56
Архангельск (8182)63-90-72
Астрахань (8512)99-46-04
Барнаул (3852)73-04-60
Белгород (4722)40-23-64
Благовещенск (4162)22-76-07
Брянск (4832)59-03-52
Владивосток (423)249-28-31
Владикавказ (8672)28-90-48
Владимир (4922)49-43-18
Волгоград (844)278-03-48
Вологда (8172)26-41-59
Воронеж (473)204-51-73
Екатеринбург (343)384-55-89

Иваново (4932)77-34-06
Ижевск (3412)26-03-58
Иркутск (395)279-98-46
Казань (843)206-01-48
Калининград (4012)72-03-81
Калуга (4842)92-23-67
Кемерово (3842)65-04-62
Киров (8332)68-02-04
Коломна (4966)23-41-49
Кострома (4942)77-07-48
Краснодар (861)203-40-90
Красноярск (391)204-63-61
Курск (4712)77-13-04
Курган (3522)50-90-47
Липецк (4742)62-20-81

Магнитогорск (3519)55-03-13
Москва (495)268-04-70
Мурманск (8152)59-64-93
Набережные Челны (8552)20-53-41
Нижний Новгород (831)429-08-12
Новокузнецк (3843)20-46-81
Новосибирск (383)227-86-73
Омск (3812)21-46-40
Орел (4862)44-53-42
Оренбург (3532)37-68-04
Пенза (8412)22-31-16
Петрозаводск (8142)55-98-37
Псков (8112)59-10-37
Пермь (342)205-81-47

Ростов-на-Дону (863)308-18-15
Рязань (4912)46-61-64
Самара (846)206-03-16
Санкт-Петербург (812)309-46-40
Саратов (845)249-38-78
Севастополь (8692)22-31-93
Саранск (8342)22-96-24
Симферополь (3652)67-13-56
Смоленск (4812)29-41-54
Сочи (862)225-72-31
Ставрополь (8652)20-65-13
Сургут (3462)77-98-35
Сыктывкар (8212)25-95-17
Тамбов (4752)50-40-97
Тверь (4822)63-31-35

Тольятти (8482)63-91-07
Томск (3822)98-41-53
Тула (4872)33-79-87
Тюмень (3452)66-21-18
Ульяновск (8422)24-23-59
Улан-Удэ (3012)59-97-51
Уфа (347)229-48-12
Хабаровск (482)92-98-04
Чебоксары (8352)28-53-07
Челябинск (351)202-03-61
Череповец (8202)49-02-64
Чита (3022)38-34-83
Якутск (4112)23-90-97
Ярославль (4852)69-52-93

Россия +7(495)268-04-70

Казахстан +7(7172)727-1322

Киргизия +996(312)96-26-47