

MODEL 988

PNEUMATIC CONTROL VALVE FOR GENERAL & CHEMICAL SERVICE

OVERVIEW

The Model 988 is a globe-style, pneumatic control valve designed primarily for general and chemical service. The valve's body/trim materials are available in WCB/316L SST, CF3M/316L SST, or CW-12MW/Hast. C constructions.

Standard trim is metal seated design giving Class IV shutoff. Optional composition seat design gives Class VI shutoff. Available in body sizes 3/4" through 2" (DN20–DN50). End connections available are NPT, socketweld or flanged.

FEATURES

- All wetted trim components of 316L SST or Hastelloy C.
- Dual stem guiding:
 - improved shutoff,
 - increased packing life,
 - maximized stability.
- Standard internally live-loaded V-ring packing.
- Multiple packing designs to meet reduced fugitive emission levels.
- Flow-to-open design for increased:
 - rangeability,
 - stability.
- Quick change trim.
- High pressure drop capability, up to 1480 psid (102.0 Bard).
- Multiple reduced trim selections.
- Equal percent or linear characterization.
- External corrosion protection.
- Face-to-Face dimensions - ISA 75.08.07 ("Long Pattern").
- Standard Actuator compliant with IEC 60534-6-1 for mounting standardized positioners.



MODEL 988
Model C27 Actuator
(ATO-FC Action)
"Long Pattern"



LINE SIZES AVAILABLE

3/4" (DN20), 1" (DN25), 1-1/2" (DN40), 2" (DN50)



END CONNECTIONS

NPT, FLANGED, SOCKET WELD



COMMON APPLICATIONS

STEAM, AIR, OIL, WATER, INDUSTRIAL GASES



DESIGN PRESSURE

MAX INLET: UP TO 1480 psig (102 Barg)
MAX PRESSURE DROP: 1480 psig (102 Barg)

Алматы (7273)495-231
Ангарск (3955)60-70-56
Архангельск (8182)63-90-72
Астрахань (8512)99-46-04
Барнаул (3852)73-04-60
Белгород (4722)40-23-64
Благовещенск (4162)22-76-07
Брянск (4832)59-03-52
Владивосток (423)249-28-31
Владикавказ (8672)28-90-48
Владимир (4922)49-43-18
Волгоград (844)278-03-48
Вологда (8172)26-41-59
Воронеж (473)204-51-73
Екатеринбург (343)384-55-89

Иваново (4932)77-34-06
Ижевск (3412)26-03-58
Иркутск (395)279-98-46
Казань (843)206-01-48
Калининград (4012)72-03-81
Калуга (4842)92-23-67
Кемерово (3842)65-04-62
Киров (8332)68-02-04
Коломна (4966)23-41-49
Кострома (4942)77-07-48
Краснодар (861)203-40-90
Красноярск (391)204-63-61
Курск (4712)77-13-04
Курган (3522)50-90-47
Липецк (4742)52-20-81

Магнитогорск (3519)55-03-13
Москва (495)268-04-70
Мурманск (8152)59-64-93
Набережные Челны (8552)20-53-41
Нижний Новгород (831)429-08-12
Новокузнецк (3843)20-46-81
Новыйорск (3496)41-32-12
Новосибирск (383)227-86-73
Омск (3812)21-46-40
Оренбург (4862)44-53-42
Орск (3532)37-68-04
Пенза (8412)22-31-16
Петрозаводск (8142)55-98-37
Псков (8112)59-10-37
Пермь (342)205-81-47

Ростов-на-Дону (863)308-18-15
Рязань (4912)46-61-64
Самара (846)206-03-16
Санкт-Петербург (812)309-46-40
Саратов (845)249-38-78
Северодвинск (8692)22-31-93
Саранск (8342)22-96-24
Симферополь (3652)67-13-56
Смоленск (4812)29-41-54
Сочи (862)225-72-31
Ставрополь (8652)20-65-13
Сургут (3462)77-98-35
Сыктывкар (8212)25-95-17
Тамбов (4752)50-40-97
Тверь (4822)63-31-35

Тольятти (8482)63-91-07
Томск (3822)98-41-53
Тула (4872)33-79-87
Тюмень (3452)66-21-18
Ульяновск (8422)24-23-59
Улан-Удэ (3012)59-97-51
Уфа (347)229-48-12
Хабаровск (4212)92-98-04
Чебоксары (8352)28-53-07
Челябинск (351)202-03-61
Череповец (8202)49-02-64
Чита (3022)38-34-83
Якутск (4112)23-90-97
Ярославль (4852)69-52-93

STANDARD / GENERAL SPECIFICATIONS

Body Sizes:	3/4", 1", 1-1/2" and 2". (DN20, 25, 40, and 50).
Body Pressure Temperature Rating:	Meets ANSI B16.34 for 150# or 300# Pressure Classes for cast carbon steel (CS), cast stainless steel (SST) and cast hastelloy (H-C). See Table 1.
Max. Inlet Pressure:	Up to 1480 psig (102.0 Barg).
Working Temperature Range:	Standard, all materials: -20°F to +450°F (-29°C to +232°C). Optional, CS or SST materials: -20°F to +750°F (-29°C to +399°C).
End Connections:	<p><u>Female NPT</u> – All sizes and materials only. F-to-F dimensions per ISA S75.08-03.</p> <p><u>Socket Weld</u> – All sizes; CS and SST body materials only. F-to-F dimensions per ISA S75.08.03.</p> <p><u>Flanged</u> – All sizes and body materials. Separable Type; standard is CS flanges and CS split rings, optional SST.</p> <p> <u>150# RF and 300# RF:</u> Mating dimensions in accordance with ANSI B16.5. F-to-F dimensions per ISA 75.08.07.</p> <p> <u>PN16, PN25 and PN40:</u> Standard ANSI raised facing dimensions on body. Mating bolt circle and bolt hole dimensions in accordance with ISO 7005-1. See Figure 9.</p>
Max. Pressure Drop:	Up to 1480 psid (102.0 Bard) for Full, 1-Step, 2-Step, 3-Step, 4-Step, 5-Step and 6-Step reduced ports. See Tables 2 and 3.
Seat Leakage:	Meets ANSI/FCI 70-2 (Rev. 1982). Standard – Metal Seated – Class IV. Optional – TFE Soft Seated – Class VI, with metal-to-metal backup.
Flow Direction:	<u>Standard:</u> Flow-to-Open (FTO). Minimizes packing sealing pressure level. (Not recommended for Flow-to-Close direction.)
Inherent Flow Characteristic:	Equal Percent or Linear; FTO direction only.

Rangeability:

Body Size		Port Size			
		Reduced			FULL
inch	(DN)	3, 4, 5, & 6-Step	2-Step	1-Step	
3/4"	(20)	25:1	35:1	47.5:1	45:1
1"	(25)	25:1	35:1	50:1	
1-1/2"	(40)	–	–	50:1	
2"	(50)	–	–	50:1	

Flow Capacity: Per ISA 75.11.01 Standard
See Tables 5 and 6.

Body Size		Port - Orifice Description	Port - Orifice Size		Cv Max.	
			inch	(mm)	= %	Lin.
3/4"	(20)	Full	.750	(19.1)	10.7	11.6
		1-Step Reduced	.562	(14.3)	6.7	7.1
1"	(25)	Full	.750"	(19.1)	11.8	12.7
		1-Step Reduced	.562"	(14.3)	7.0	7.5
3/4" & 1"	(20 & 25)	2-Step Reduced	.562"	(14.3)	4.1	4.3
		3-Step Reduced	.332"	(8.4)	2.5	2.6
		4-Step Reduced *	.205"	(5.2)	–	1.1
		5-Step Reduced *	.155"	(3.9)	–	0.58
1-1/2"	(40)	Full	1.250"	(31.8)	26	27
		Reduced	.750"	(19.1)	10.4	10.8
2"	(50)	Full *	1.875"	(47.6)	47	47
		Full **	1.875"	(47.6)	50	50
		Reduced	1.000"	(25.4)	19	19

* Metal Seat ; ** Soft Seat

Actuators: Spring-Diaphragm Type. Models C27 or C53. Select "direct" or "reverse" action; field reversible.

Air-to-Open, Fail Close. Increase loading pressure pushes stem up, plug opens.
Air-to-Close, Fail Open. Increase loading pressure pushes stem down, plug closes.

See Tables 2 and 3 for proper selection of required bench setting range spring and Model number.

Painting: Standard – All non corrosion resistant portions are powder coated per Spec. S-1743 and /or with corrosion resistant epoxy paint per Cashco Spec #S-1606.

BODY SUB-ASSEMBLY SPECIFICATIONS

Body/Bonnet Materials: CS – ASTM A216, Gr. WCB.
SST – ASTM A351, Gr. CF3M (316L).
H-C – ASTM A494, Gr. CW-12MW (Similar to “Hasteloy C”).

Separable Flange Materials: Standard: All body materials;
Flanges – CS per ASTM A216, Gr. WCB, or equal;
Split Rings – CS.
Optional: SST or H-C body materials;
Flanges – SST per ASTM A351, Gr. CF3M, or equal;
Split Rings – 316 SST.
Optional: All body materials;
Flanges – CS per above;
Split Rings – 316 SST.

Trim: Function of packing design and body material.

Seat Design	Trim Designation #	Body Materials	Basic Trim Description
Metal	S1R, S1S, S1RE, S1SE	CS or SST	316L SST
	S40, S40E	CS or SST	NACE
	S1HT	CS or SST	High Temp
	HC1, HC1E	CS, SST or H-C	H-C
Composition Soft	S3R, S3S, S3RE, S3SE	CS or SST	316L SST/TFE
	S40T, S40TE	CS or SST	NACE/TFE
	HC3, HC3E	CS, SST or H-C	H-C/TFE

See Table 4 for complete trim material specifications.

Internal Gaskets: Standard – Spiral-Wound Type ;
CS or SST Body – 316L SST with carbon filler,
H-C Body – Hastelloy C with carbon filler.

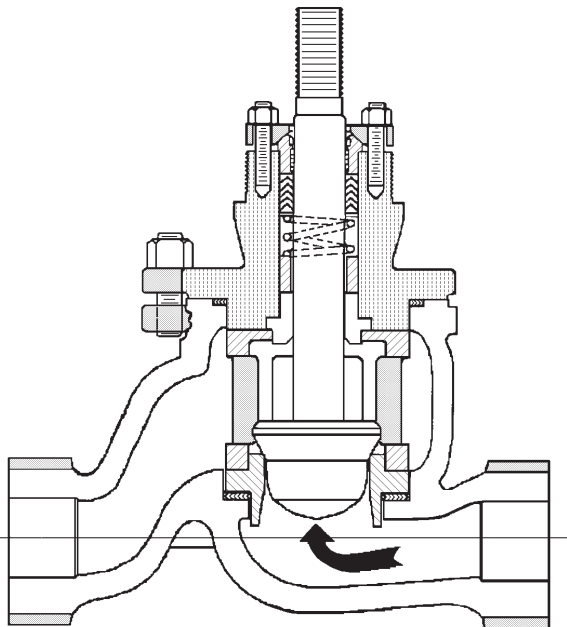

FIGURE 1

Body Sub-Assembly Internal Design – Metal Seated with Internal Live-Loading

Stem Size: 0.625" (15.9mm) diameter, all body sizes.

Plug Travel:

Body Size inch (DN)	Travel/Stroke	
	inch	(mm)
3/4", 1", 1-1/2" & 2" (20, 25, 40 & 50)	.750"	(19.0)

Bonnet Bolting:

Zinc plated alloy steel.
CS Body/Bonnet: All standard and optional constructions.
Studs: ASTM A193, Gr. B7;
Nuts: ASTM A194, Gr. 2H.
SST or H-C Body/Bonnet: Std. construction and Opt-40 (NACE) Construction.
Studs: ASTM A193, Gr. B7;
Nuts: ASTM A194, Gr. 2H.
SST Body/Bonnet: Opt-35 High Temperature Construction (no plating).
Studs: ASTM A193, Gr. B8M, Cl. 2;
Nuts: ASTM A194, Gr. 8M-S1.

Packing Apparatus:

Std – Internal Live-Loaded & Jammed:
Flange – 316 SST;
Follower & Upper Guide – per Trim Designation Number.
Optional – External Live-Loaded:
Retainers – 316 SST;
Spacer – 316 SST;
Follower & Upper Guide – per Trim Designation Number;
Belleville Washers – 17-7PH SST.
All Designs – Bolting:
CS Body – All constructions;
Studs – 18-8 SST,
Nuts – 18-8 SST.
SST or H-C Body – All constructions except Opt-35;
Studs – 18-8 SST,
Nuts – 18-8 SST.
SST Body – Opt-35 High Temperature Construction;
Studs – ASTM A193, Gr. B8M, Cl. 2;
Nuts – ASTM A194, Gr. 8M-S1.

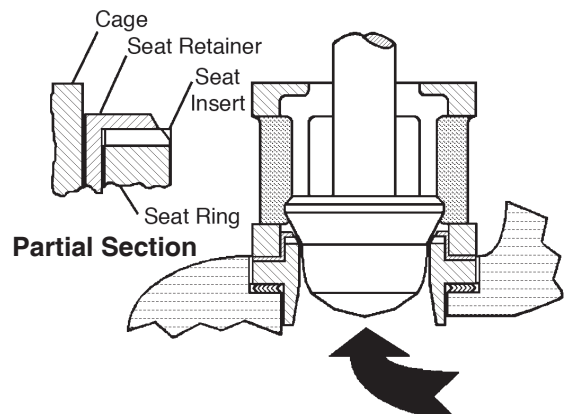

FIGURE 2

Composition Soft Seat Design

Packing:

All packing ring sets are complete with upper and lower non-extrusion adapters.

Live-Loaded (LL): (See Figure 3.)

Standard: Internal LL, virgin TFE V-ring.

Opt-EXT: External LL, virgin TFE V-ring.

Opt-HTE: External LL, carbon graphite rings.

Opt-KRI: Internal LL, DuPont Kalrez/ TFE rings with CRCC adapters.

Opt-KRE: Same as 'KRI', except external LL.

Jammed (Non-LL): (See "Option Specifications").

Opt-34: Dual packing, TFE V-ring, lantern ring spacer; 3 variations.

Opt-38J: Virgin TFE V-ring, dead-loaded.

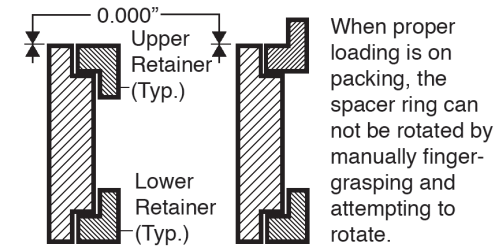

All packings with external live-loading except Opt-HTE-Lo.

Opt-HTE-Lo Only

With Proper Loading on Upper Retainer

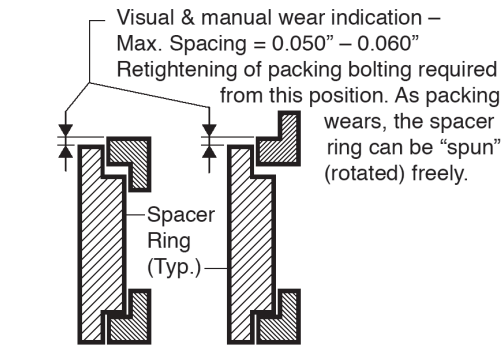

All packings with external live-loading except Opt-HTE-Lo.

Opt-HTE-Lo Only

With Minimum Loading on Upper Retainer

The mechanism for external live-loading of valve stem packing is patented. The design features —

- Manual and visual indication of packing ring wear.
- Allows levels of loading with same parts; only rearrangement is required.
- Manual indication of proper loading force.

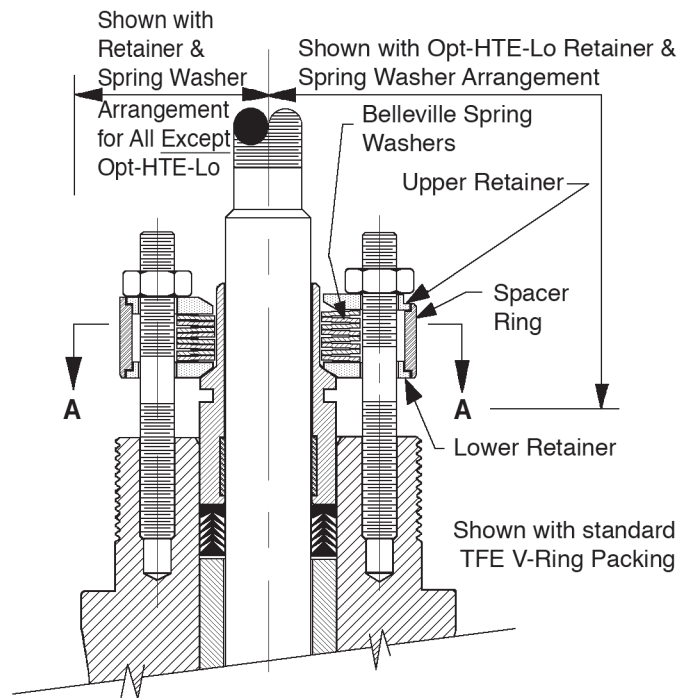

ACTUATOR SUB-ASSEMBLY SPECIFICATIONS

(Continued on page 5)

Size, Stroke & Volumes:

Basic Actuator	Dia-phragm Area	Nominal Stroke	Volumes						
			Clearance		Displacement				
Model	Action	in ²	(cm ²)	in	(mm)	in ³	(cm ³)	in ³	(cm ³)
C27	ATC	32	(209)	0.5	(12.7)	30.3	(496.5)	16.2	(265.5)
	ATO					28.2	(462.1)	16.4	(268.7)
	ATC			0.75	(19.05)	25.8	(422.8)	25.4	(416.2)
	ATO					24.4	(399.8)	24.1	(394.9)
C53	ATC	53	(342)	0.5	(12.7)	46.1	(755.4)	28.2	(462.1)
	ATO					44.3	(725.9)	24.7	(404.8)
	ATC			0.75	(19.05)	38.4	(629.3)	39.3	(644.0)
	ATO					36.9	(604.7)	39.0	(639.0)

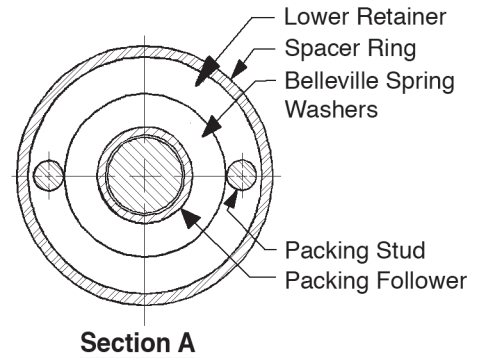

FIGURE 3
External Live-Loaded Packing Details

Ambient Temperature: -20° to +180°F (-28° to +83°C).
 -20° to +140°F (-29° to +60°C) with electrical accessories.

Bench Range & Max/Norm Pressures:

Bench Range		Air Pressures			
		Normal Supply		Design Max.	
psig	(Barg)	psig	(Barg)	psig	(Barg)
5-15	(0.34-1.03)	20	(1.4)	100	(6.9)
15-60	(1.03-4.14)	75	(5.2)	100	(6.9)

No springs available for split ranges. A Positioner is required for split range input signal.

Materials:

Part	Material
Diaphragm	Buna-N w/Polyester Insert
Upper & Lower Case, Yoke	Steel
Attachment Hub	17-4 PH SST
Stem	316/316L SST
Diaphragm Plate, Stem Spacer, Spring Plate, Hub Nut, Stem Bolt, Stem Lock Washer	Steel
Diaphragm Washer	316/316L SST
Diaph. Washer O-ring, Hub O-ring, Stem O-ring	Buna-N
Bolts & Nuts	Steel Plated
Spring	Steel

OPTION SPECIFICATIONS

Option -3: **MANUAL HANDWHEEL.** Overrides the actuator spring force to allow manual stroking of valve. Single acting design, side-mounted. For ATO-FC action, handwheel operator "opens" the plug against spring force; may be utilized as a travel stop to prevent full closure. For ATC-FO action, handwheel operator "closes" the plug against spring force; may be utilized as an "up" travel stop to prevent full opening.

Option -15: **STELLITED TRIM.** For metal seated 316 SST designs only; limited to use with S1R, S1S, S1RE, S1SE or S1HT trim designation numbers only. Seat ring and plug seating surfaces are covered with Stellite #6 material. Recommended for flashing or partially cavitating liquid service, or where extended time periods of ON-OFF or low flow (less than 10% open) operation occur and good shutoff is required.

Option -26: **LEAK-OFF CONNECTION.** 1/4" NPT tapped opening on bonnet. Complete with removable steel plug for all body materials. Located between primary and secondary packing sets when supplied with Option -34, Dual Packing. See Figure 4.

Option -34: **DUAL PACKING.** Two sets of standard TFE V-ring packing separated by a lantern ring of same material as trim material. Use for lethal, toxic, explosive, etc., type fluids, where extra packing sealing protection is desired; also used for vacuum service.

Arrangement A – Pressure inside valve is always greater than ambient pressure; see Figure 5.

Arrangement B – Pressure inside valve is always less than (i.e. vacuum) ambient pressure; see Figure 6.

Arrangement C – Pressure inside valve is alternately greater than or less than (i.e. vacuum) ambient pressure; see Figure 7.

Option -35: **HIGH TEMPERATURE CONSTRUCTION.** Apply where temperatures from 450° to 750°F (232° to 399°C) are expected. Includes high strength, high temperature alloy bolting for the bonnet and packing retainer when applied with a SST body. Must select Opt -HTE stem packing design. Limited to use with trim designation S1HT ONLY. Select C27 Act. with 15-60 psig bench or C53 Act.

Option -EXT: **TFE V-RING PACKING (External)** Standard internal live-loaded (LL) design is replaced by patented external LL design. Includes SST Belleville spring washers enclosed within a SST spacer with SST upper and lower retainers (see Figure 3), and a variation of the standard packing follower. Temperature range: -20 to +450°F (-29 to +232°C).

Option -HTE: **HIGH TEMPERATURE PACKING.** Includes patented externally live-loaded design. Packing set includes braided carbon yarn, graphite embedded upper and lower rings; high density graphite formed rings acting as non-extrusion adapters; and compressed carbon graphite ribbon

Option -HTE (Cont): formed into one-piece rings. Special packing follower includes carbon bushing. Temperature range: -20° to +750°F (-29° to +399°C). Opt-HTE is further classified as to max. inlet pressure — Opt-HTE-Lo is for inlet pressures up to 250 psig (17.2 Barg); Opt-HTE-Hi is for inlet pressures greater than 250 psig (17.2 Barg). **NOTE:** If application is for temperatures greater than 450 °F (232 °C), Opt-35 is also required.

Option -KRI: **KALREZ PACKING (Internal)** Standard packing is replaced with DuPont “Kalrez” fluoroelastomer, Series 500 KVSP packing set, consisting of one carbon filled TFE V-ring, two Kalrez V-rings, and upper and lower CRCC non-extrusion adapter rings. Uses standard internal live-loading. Temperature range: -20° to +450°F (-29° to +232°C).

Option -KRE: **KALREZ PACKING (External).** Incorporates external live-loaded features of packing Opt-EXT, and packing rings of packing KRI. Temperature range: -20° to +450°F (-29° to +232°C).

Option -38J: **JAMMED PACKING.** Live loaded packing spring replaced by a fixed spacer of same material as trim material; see Figure 8.

Option -40:

NACE SERVICE. Internal wetted portions meet NACE standard MR0175-90 revision, when the exterior of the valve is not directly exposed to a sour gas environment, buried, insulated or otherwise denied direct atmospheric exposure. Apply in sour gas, sour crude, or service with hydrogen sulfide (H₂S) in the flow mixture. Limits effects of sulfide stress corrosion cracking. Use with CS or SST body/bonnet materials, and only with trim designations S40, S40E, S40T, or S40TE. Certificate of compliance supplied on request.

Option -55:

SPECIAL CLEANING. Cleaned and packaged per Cashco Specification #S-1134. Suitable for oxygen service and other fluids. SST BODIES ONLY.

Option -56:

SPECIAL CLEANING. Special cleaning procedure per Cashco Specification #S-1542. Suitable for fluids other than oxygen. For all body materials.

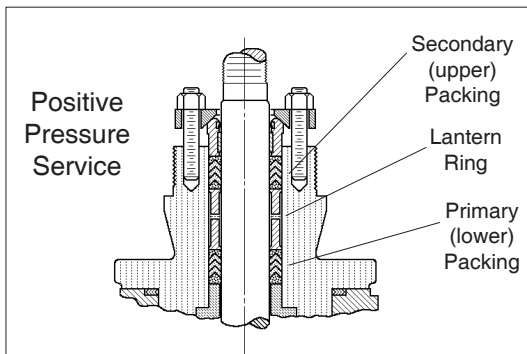

FIGURE 5
Dual Packing – Arr. “A”
Option-34A

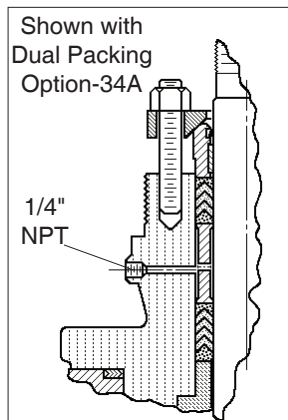

FIGURE 4
Leak-Off Conn.
Option-26

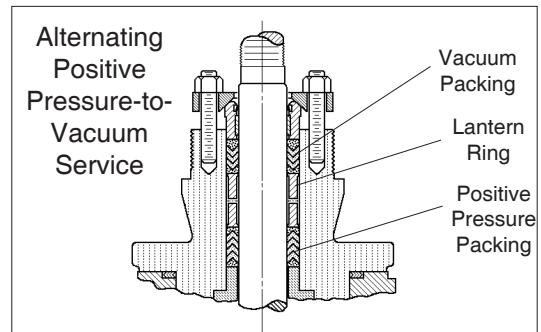

FIGURE 7
Dual Packing – Arr. “C”
Option-34C

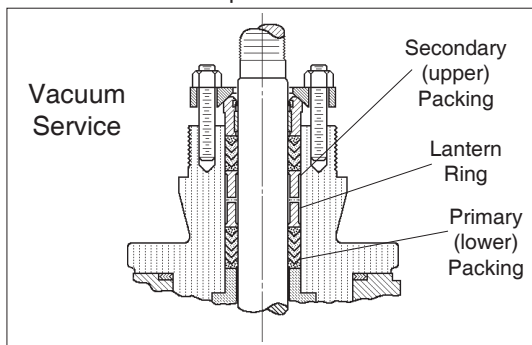

FIGURE 6
Dual Packing – Arr. “B”
Option-34B

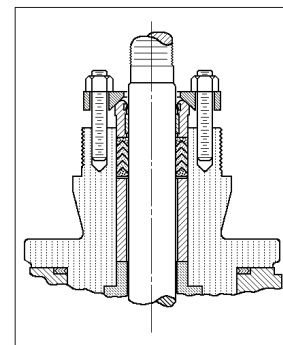

FIGURE 8
Jammed Packing
Option-38

MOUNTED ACCESSORY SPECIFICATIONS

Positioners: ***NOTE:** PMV Positioners are not FM Approved at this time. If you need FM Approval, please specify the Siemens PS2.*

General: PMV Positioners. Aluminum housing with corrosion resistant powder coated epoxy. Pneumatic output load as required by actuator bench range. Field reversible action. Mounting dimensions per IEC 60534-6-1 Standard.

P/P Pneumatic. Model P5 features SST cam with a simple cam locking device, tapped exhaust port for venting media, external zero adjustment. Input signal 3-15 psig, Includes gauge ports, no gauges. Analog only.

I/P Electro-Pneumatic. Model D20 Digital or Hart compatible. Features single button self-calibration. input signal 4-20mA. Optional gauge block with gauges for Models D20 D and D20 A.

Model D20 D is general purpose.

Model D20 A is Intrinsically safe, Ex ia ATEX.

Model D20 E is ATEX EEX d IIB+H₂, T6 FM Approved. Gauge block is built in, no gauges.

Not available with limit switch option. - **Approval Pending**

Model D3 Digital, Hart, Profibus, or Fieldbus compatible. Input signal 4-20mA. Features large graphic display. Optional gauge block for Models D3 X and D3 I, no gauges.

Model D3 X is general purpose.

Model D3 I is Intrinsically safe, ATEX EEX ia IIC T4.

Model D3 E is ATEX EEX d IIB+H₂, T6 CSA CLS 1 DIV 1

FM CLS 1 DIV 1 - **Approval Pending**

Gauge block is built in, no gauges. Not available with limit switch option.

Model PS2 is Digital, Hart, Fieldbus and Profibus compatible. Input signal 4-20mA. Features a Makrolon housing, (Aluminum for Explosion Proof.) Mounting dimensions per IEC 60534-6-1 Standard.

Model PS2-1 is general purpose.

Model PS2-2 is Intrinsically safe, ATEX Ex ia IIC T6/T4, FM CLS 1 DIV 1, CSA CLS 1 DIV 1, SIL 2

Model PS2-3 EX d IIC T6/T4, SIL 2. Not available with limit switch option.

All I/P positioners not available with 764's.

Air Tubing: Instrument air tubing SST with SST fittings.

Airset: Model 5200P instrument air supply regulator. Use with positioners. Bracket mounted to actuator casing. Supplied with gauge. See technical bulletin 5200P-TB.

Solenoid Valve: Standard Brass: Available in standard weather-proof model. Brass body, 1/4" female NPT connections. Nipple mounted to actuator casing. 120 VAC, 60 Hz power supply, CSA Approved Class 3221-01, NEMA 2,3,3S,4,4X. 8" HF utilizes a direct mount NAMUR mount style.

X-Proof or SST construction: Consult Factory.

Standard installation vents actuator and drives valve to fail-safe position upon loss of electrical power.

Consult factory for 230/1/50, or 120 VDC power supplies, or intrinsically safe (IS) service.

Transducers: FM, CSA approved NEMA 4X CI 1, Div 1 and CI 1, Div 2

Other 764 P/PD pressure controller.

Accessories: Lockup valve.
Position transmitter.

Limit Switches: Model D20 and D3 positioners, switches are available, unit is enclosed in the positioner housing.

Limit and proximity switch options not available on Explosion proof rated positioners.

TECHNICAL SPECIFICATIONS

**TABLE 1
MAXIMUM ALLOWABLE WORKING PRESSURE / TEMPERATURE RATINGS
NPT & Socket Weld End Connections**

Body Size	Material	Option Nos.	End Connection	English Units		Metric Units		
				Pressure psig	Temperature °F	Pressure (Barg)	Temperature °C	
3/4" & 1" (DN20 & DN25)	CS, A-216, WCB, SST, A351 Grade CF3M * Ni-Mo-Cr (HC) A494, Gr.CW-12MW	None	NPT & SW	1480	-20 to +100	(102)	(-29 to +38)	
				1390	200	(96)	(93)	
				1350	300	(93)	(149)	
				1310	400	(90)	(204)	
		1230		500	(85)	(260)		
		1130		600	(78)	(316)		
		1105		650	(76)	(343)		
		1100		700	(76)	(371)		
940		750	(65)	(399)				
1-1/2" (DN40)		CS, A-216, WCB, SST, A351 Grade CF3M * Ni-Mo-Cr (HC) A494, Gr.CW-12MW	None	NPT & SW	1075	-20 to +100	(74)	(-29 to +38)
					1010	200	(70)	(93)
					980	300	(68)	(149)
					950	400	(66)	(204)
			895		500	(62)	(260)	
			820		600	(57)	(316)	
			805		650	(56)	(343)	
	800		700		(55)	(371)		
685	750		(47)	(399)				
2" (DN50)	CS, A-216, WCB, SST, A351 Grade CF3M * Ni-Mo-Cr (HC) A494, Gr.CW-12MW		None	NPT & SW	1330	-20 to +100	(92)	(-29 to +38)
					1250	200	(86)	(93)
					1215	300	(84)	(149)
					1175	400	(81)	(204)
			1105		500	(76)	(260)	
			1015		600	(70)	(316)	
			995		650	(69)	(343)	
		990	700		(68)	(371)		
845		750	(58)	(399)				

* Pressure Rating shall not exceed 375 psig (25.8 Barg) when body material is SST and process medium is oxygen. (CGA G-4.4 2012)
NOTE 1: CS separable flanges with CS body material. CS or SST separable flanges with SST or H-C body material. Opt-35 is not available for HC body material.

TABLE 1 - Cont'd
MAXIMUM ALLOWABLE WORKING PRESSURE / TEMPERATURE RATINGS
Flanged End Connections

Body Size	Material	Option Nos.	End Connection	English Units		Metric Units	
				Pressure psig	Temperature °F	Pressure (Barg)	Temperature (°C)
ALL	CS, A-216, WCB or Equal	None	150# RF Flanged (NOTE 1)	285	-20 to +100	(20)	(-29 to +38)
				260	200	(18)	(93)
				230	300	(16)	(149)
				200	400	(14)	(204)
				170	500	(12)	(260)
				140	600	(10)	(316)
				125	650	(9)	(343)
				110	700	(8)	(371)
				95	750	(7)	(399)
		-35 (T>450 °F)	300# RF Flanged (NOTE 1)	740	-20 to +100	(51)	(-29 to +38)
				680	200	(47)	(93)
				655	300	(45)	(149)
				635	400	(44)	(204)
				605	500	(41)	(260)
				570	600	(39)	(316)
				550	650	(38)	(343)
				530	700	(36)	(371)
				505	750	(35)	(399)

Body Size	Material	Option Nos.	End Connection	English Units		Metric Units	
				Pressure psig	Temperature °F	Pressure (Barg)	Temperature (°C)
ALL	SST, A351 Grade CF3M *	None	150# RF Flanged (NOTE 1)	275	-20 to +100	(19)	(-29 to +38)
				235	200	(16)	(93)
				215	300	(15)	(149)
				195	400	(13)	(204)
				170	500	(12)	(260)
				140	600	(10)	(316)
				125	650	(9)	(343)
				110	700	(8)	(371)
				95	750	(7)	(399)
		-35 (T>450 °F)	300# RF Flanged (NOTE 1)	720	-20 to +100	(50)	(-29 to +38)
				620	200	(43)	(93)
				560	300	(39)	(149)
				515	400	(36)	(204)
				480	500	(33)	(260)
				450	600	(31)	(316)
				440	650	(30)	(343)
				435	700	(30)	(371)
				425	750	(29)	(399)

* Pressure Rating shall not exceed 375 psig (25.8 Barg) when body material is SST and process medium is oxygen. (CGA G-4.4 2012)

NOTE 1: CS separable flanges with CS body material. CS or SST separable flanges with SST or H-C body material.

**TABLE 2 - MAXIMUM PRESSURE DROP - PSID (BARD)
CLASS IV SEAT LEAKAGE FOR METAL SEATED; CLASS VI SEAT LEAKAGE FOR COMPOSITION SEATED
SHUTOFF PRESSURES MAY BE FURTHER DERATED BY MAWP**

LINE SIZE	PORT SIZE	ORIFICE SIZE		ACTUATOR			DIRECT ATO-FC & REVERSE ATC-FO				
				MODEL NO.	BENCH RANGE		METAL SEAT		COMP SEAT		
		INCH	(mm)		PSIG	(BARG)	PSID	(BARD)	PSID	(BARD)	
"3/4" - 1" (DN20 & DN25)"	FULL	0.750	(19.1)	C27	5-15	(0.34-1.03)	131	(9.0)	237	(16.4)	
					15-60	(1.03-4.14)	819	(56.5)	926	(63.8)	
				C53	5-15	(0.34-1.03)	357	(24.6)	463	(31.9)	
					15-60	(1.03-4.14)	1480	(102.0)	1480	(102.0)	
	1-STEP & 2-STEP REDUCED	0.562	(14.3)	C27	5-15	(0.34-1.03)	328	(22.6)	470	(32.4)	
					15-60	(1.03-4.14)	1480	(102.0)	1480	(102.0)	
				C53	5-15	(0.34-1.03)	730	(50.3)	873	(60.2)	
					15-60	(1.03-4.14)	1480	(102.0)	1480	(102.0)	
	3-STEP REDUCED	0.332	(8.4)	C27	5-15	(0.34-1.03)	1274	(87.8)	1480	(102.0)	
					15-60	(1.03-4.14)	1480	(102.0)	1480	(102.0)	
				C53	5-15	(0.34-1.03)	1480	(102.0)	1480	(102.0)	
					15-60	(1.03-4.14)	1480	(102.0)	1480	(102.0)	
	4-STEP REDUCED	0.205	(5.2)	C27	5-15	(0.34-1.03)	1480	(102.0)	N/A	N/A	
					15-60	(1.03-4.14)	1480	(102.0)	N/A	N/A	
				C53	5-15	(0.34-1.03)	1480	(102.0)	N/A	N/A	
					15-60	(1.03-4.14)	1480	(102.0)	N/A	N/A	
	5-STEP & 6-STEP REDUCED	0.155	(3.9)	C27	5-15	(0.34-1.03)	1480	(102.0)	N/A	N/A	
					15-60	(1.03-4.14)	1480	(102.0)	N/A	N/A	
				C53	5-15	(0.34-1.03)	1480	(102.0)	N/A	N/A	
					15-60	(1.03-4.14)	1480	(102.0)	N/A	N/A	
	"1-1/2" (DN40)"	FULL	1.250	(31.8)	C27	5-15	(0.34-1.03)	N/A	N/A	60	(4.1)
						15-60	(1.03-4.14)	244	(16.8)	308	(21.2)
					C53	5-15	(0.34-1.03)	77	(5.3)	141	(9.7)
						15-60	(1.03-4.14)	487	(33.6)	551	(38.0)
REDUCED		0.750	(19.1)	C27	5-15	(0.34-1.03)	131	(9.0)	237	(16.4)	
					15-60	(1.03-4.14)	819	(56.5)	926	(63.8)	
	C53			5-15	(0.34-1.03)	357	(24.6)	463	(31.9)		
				15-60	(1.03-4.14)	1075	(74.1)	1075	(74.1)		
"2" (DN50)"	FULL	1.875	(47.6)	C27	5-15	(0.34-1.03)	N/A	N/A	CF	CF	
					15-60	(1.03-4.14)	80	(5.5)	122	(8.4)	
				C53	5-15	(0.34-1.03)	CF	CF	CF	CF	
					15-60	(1.03-4.14)	188	(13.0)	231	(15.9)	
				C110	5-15	(0.34-1.03)	104	(7.2)	147	(10.1)	
					15-60	(1.03-4.14)	482	(33.3)	525	(36.2)	
	REDUCED	1.000	(25.4)	C27	5-15	(0.34-1.03)	CF	CF	114	(7.8)	
					15-60	(1.03-4.14)	421	(29.0)	501	(34.5)	
				C53	5-15	(0.34-1.03)	161	(11.1)	241	(16.6)	
					15-60	(1.03-4.14)	802	(55.3)	882	(60.8)	
C110	5-15	(0.34-1.03)	505	(34.8)	585	(40.4)					
	15-60	(1.03-4.14)	1330	(91.7)	1330	(91.7)					

- 1) CF = Consult Factory where differential pressures are below 50 psid preventing seat leakage evaluation per Cashco S-1597 at 50 psid.
- 2) Excessive differential pressures have been derated to the maximum allowable working pressure for each size at ambient conditions. Further derating may be necessary based on valve body pressure/temperature ratings.
- 3) ATC-FO values for 5-15 psig bench range based on maximum 20 psig (1.4 barg) supply pressure with use of a positioner. ATC-FO values for 15-60 psig bench range based on maximum 75 psig (5.2 barg) supply pressure with use of a positioner.

**TABLE 3
TRIM MATERIALS VS. DESIGNATION NOS.**

Part Description	METAL SEAT – Trim Designation Nos.								
	S1R *	S1S *	S40 **	HC1	√ S1HT *	S1RE *	S1SE *	S40E **	HC1E
Plug/Stem Assy.	316L SST	316L SST	316L SST	Hast C-22	316L SST	316L SST	316L SST	316L SST	Hast C-22
Seat Ring	316L SST	316L SST	316L SST	Hast C-22	316L SST	316L SST	316L SST	316L SST	Hast C-22
Cage	CF3M	CF3M	CF3M	CW-12MW	CF3M	CF3M	CF3M	CF3M	CW-12MW
Upper Stem Guide	Rulon Tape	Rulon Tape	Rulon Tape	Rulon Tape	Carbon	Rulon Tape	Rulon Tape	Rulon Tape	Rulon Tape
Lower Guide Bushing	316L SST Rulon	Stellite #6	316L SST Rulon	Hast C-22 Rulon	Stellite #6	316L SST Rulon	Stellite #6	316L SST Rulon	Hast C-22 Rulon
Packing Load Spring	Cold Worked 316 SST	Cold Worked 316 SST	Cold Worked Inconel X-750	Cold Worked Hast C-276	None	None	None	None	None
Packing Follower	316L SST	316L SST	316L SST	Hast C-22	316L SST	316L SST	316L SST	316L SST	Hast C-22
Wiper Ring	***	***	***	***	None	None	None	None	None
Spacer	316L SST	316L SST	316L SST	Hast C-22	316L SST	316L SST	316L SST	316L SST	Hast C-22
Packing Design	Internal Live-Loaded				External Live-Loaded or jammed				

Shaded column is Base (Std) Trim

Part Description	COMPOSITION / SOFT SEAT – Trim Designation Nos.							
	S3R	S3S	S40T **	HC3	S3RE	S3SE	S40TE **	HC3E
Plug/Stem Assy.	316L SST	316L SST	316L SST	Hast C-22	316L SST	316L SST	316L SST	Hast C-22
Seat Ring	316L SST	316L SST	316L SST	Hast C-22	316L SST	316L SST	316L SST	Hast C-22
Cage	CF3M	CF3M	CF3M	CW-12MW	CF3M	CF3M	CF3M	CW-12MW
Upper Stem Guide	Rulon Tape	Rulon Tape	Rulon Tape	Rulon Tape	Rulon Tape	Rulon Tape	Rulon Tape	Rulon Tape
Lower Guide Bushing	316L SST Rulon	Stellite #6	316L SST Rulon	Hast C-22 Rulon	316L SST Rulon	Stellite #6	316L SST Rulon	Hast C-22 Rulon
Packing Load Spring	Cold Worked 316 SST	Cold Worked 316 SST	Cold Worked Inconel X-750	Cold Worked Hast C-276	None	None	None	None
Packing Follower	316L SST	316L SST	316L SST	Hast C-22	316L SST	316L SST	316L SST	Hast C-22
Wiper Ring	***	***	***	***	None	None	None	None
Spacer	316L SST	316L SST	316L SST	Hast C-22	316L SST	316L SST	316L SST	Hast C-22
Seat Retainer	316L SST	316L SST	316L SST	Hast C-22	316L SST	316L SST	316L SST	Hast C-22
Seat Insert	TFE	TFE	TFE	TFE	TFE	TFE	TFE	TFE
Packing Design	Internal Live-Loaded				External Live-Loaded or Jammed			

√ Only trim recommended for temperatures greater than 450°F (232°C), and up to 750°F (399°C).

* Use these trim designation numbers for Option -15 Stellite Seating surfaces.

** Use these trims when application is required for NACE service.

*** Polyurethane / Molybdenum

Material	Material Specifications
316L SST	ASTM A479, S31603; Wrought Barstock, Annealed
CF3M	ASTM A351, Gr. CF3M; Cast 316L SST
Hastelloy C-22	ASTM B574, Alloy N06022; Wrought Barstock, Annealed
CW-12MW	ASTM A494, Gr. CW-12MW; Cast Ni-Mo-Cr, similar to "Hastelloy C".

TABLE 4
FLOW CAPACITY – Cv
EQUAL PERCENT (=%) CHARACTER
Cv @ 10% TRAVEL INCREMENTS
FL @ 10%; FL @ 100%
METAL or COMPOSITION SOFT SEAT

Body Size inch (DN)	Port Size	FL @ 10% Travel	Minimum Flow	Percent of Travel - %										FL @ 100% Travel
				10	20	30	40	50	60	70	80	90	100	
3/4" (20)	Full	.90	.24	.4	.7	1.2	1.9	2.6	3.6	5.3	7.6	9.6	10.7	.90
	1-Step Reduced	.90	.14	.3	.6	.9	1.2	1.6	2.2	3.0	4.1	5.5	6.7	
3/4" & 1" (20 & 25)	2-Step Reduced	.90	.12	.2	.4	.6	.8	1.0	1.3	1.7	2.3	3.0	4.1	.90
	3-Step Reduced	.90	.10	.14	.2	.3	.4	.5	.7	.9	1.3	1.8	2.5	
1" (25)	Full	.90	.24	.4	.7	1.2	1.9	2.6	3.6	5.3	7.6	10.2	11.8	.90
	1-Step Reduced	.90	.14	.3	.6	.9	1.2	1.6	2.2	3.1	4.3	5.7	7.0	
1-1/2" (40)	Full	.90	.52	1.2	2.3	3.4	4.5	6.3	8.8	13.7	18.5	22.8	26	.90
	Reduced	.90	.21	.6	.9	1.3	1.9	2.5	3.4	4.7	6.2	8.2	10.4	
2" (50)	Full *	.90	.94	2.9	4.2	6.1	8.9	15.1	23.4	31.5	38.2	43.7	47	.90
	Full **	.90	.94	2.9	4.2	6.1	8.9	15.1	23.4	31.5	38.2	43.7	50	
	Reduced	.90	.30	0.7	1.1	1.7	2.5	3.7	5.3	9.0	13.0	16.5	19.0	

* Metal Seat ; ** Soft Seat

TABLE 5
FLOW CAPACITY – Cv
LINEAR (Lin) CHARACTER
Cv @ 10% TRAVEL INCREMENTS
FL @ 10%; FL @ 100%
METAL or COMPOSITION SOFT SEAT

Body Size inch (DN)	Port Size	FL @ 10% Travel	Minimum Flow	Percent of Travel - %										FL @ 100% Travel
				10	20	30	40	50	60	70	80	90	100	
3/4" (20)	Full	.90	.25	1.2	2.5	3.9	5.2	6.4	7.5	8.7	9.7	10.7	11.6	.90
	1-Step reduced	.90	.15	.8	1.5	2.2	3.0	3.7	4.5	5.2	5.9	6.5	7.1	
3/4" & 1" (20, 25)	2-Step Reduced	.90	.14	.4	.8	1.2	1.7	2.1	2.5	3.0	3.4	3.8	4.3	.90
	3-Step Reduced	.90	.08	.3	.6	.8	1.1	1.4	1.7	2.0	2.3	2.5	2.6	
	4-Step Reduced *	.90	.03	.1	.2	.3	.4	.5	.7	.8	.9	1.0	1.1	
	5-Step Reduced *	.90	.02	.06	.12	.18	.24	.29	.35	.41	.46	.52	.58	
	6-Step Reduced *	.90	.01	.03	.06	.08	.11	.14	.16	.19	.22	.24	.27	
1" (25)	Full	.90	.25	1.2	2.5	3.9	5.2	6.5	7.8	9.2	10.5	11.7	12.7	.90
	1-Step Reduced	.90	.15	.8	1.5	2.2	3.1	3.8	4.6	5.4	6.2	6.9	7.5	
1-1/2" (40)	Full	.90	.54	2.6	5.0	7.4	10.0	12.6	15.2	18.2	21	24	27	.90
	Reduced	.90	.22	.9	1.8	2.7	3.7	4.6	5.7	6.8	8.0	9.4	10.8	
2" (50)	Full *	.90	.94	7.2	12.7	19.6	24.6	29.7	33.5	37.5	42.2	42.9	47	.90
	Full **	.90	.94	7.2	12.7	19.6	24.6	29.7	33.5	37.5	42.2	42.9	50	
	Reduced	.90	.35	3.4	5.1	7.2	9.5	11.6	13.4	15.1	16.6	18.0	19.0	

* Metal Seat ; ** Soft Seat

**TABLE 6
APPLICATION RECOMMENDATIONS**

Fluid		Temperature Range			Options	Trim Designation Nos.
		T<250°F (T<121°C)	250°<T<450°F (121°<T<232°C)	450°<T≤750°F (232°<T≤399°C)		
GASES	Inert Industrial (N ₂ , He, Ar)	✓	✓	—	None, -EXT	S3R, S3S, S3RE, S3SE, S1R, S1S, S1RE, S1SE
		—	—	✓	-35, HTE	S1HT
	Oxygen	✓	✓	CF	-55, -EXT	S3R, S3S, S3RE, S3SE, S1R, S1S, S1RE, S1SE
	Hydrocarbons - Clean	✓	✓	—	None, -EXT	All
		—	—	✓	-15, -35, -HTE	S1HT
	Hydrocarbons - Dirty	✓	✓	—	-15, -34	S1R, S1S, S1RE, S1SE
		—	—	✓	-15, -35, -HTE	S1HT
	Corrosive - Clean	✓	✓	CF	-34, -EXT, -KRI, -KRE	S3R, S40T, HC3, S3RE, S40TE, HC3E, S1R, S40, HC1, S1RE, HC1E
Corrosive - Dirty	✓	✓	CF	-15, -34, -EXT -KRI, -KRE	S1R, S1S, S40, S1RE, S1SE, S40, S40E, HC1, HC1E	
Cryogenic	—	—	—	—	N/R	
LIQUIDS	Clean, Non-Cavitating, Non-Flashing	✓	✓	—	None, -EXT	S3R, S3S, S3RE, S3SE, S1R, S1S, S1RE, S1SE
		—	—	✓	-15, -35, -HTE	S1HT
	Clean, Cavitating, Flashing	N/R	N/R	N/R	—	Recommend Applying Ranger QCT
	NACE (H ₂ S + HC's)	✓	✓	CF	-40, -KRI, -KRE, -EXT	S40, S40E, S40T, S40TE
	Corrosive	✓	✓	CF	-34, -EXT, -KRI, -KRE	S3R, S40T, HC3, S3RE, S40TE, HC3E, S1R, S40, HC1, S1RE, HC1E
	Abrasive	N/R	N/R	N/R	—	Recommend Applying Ranger QCT
STEAM	P1 < 150 psig (10.3 Barg)	Saturated			None, -EXT	S1R, S1S, S1RE, S1SE, S3R, S3S, S3RE, S3SE
	150 psig < P1 < 400 psig (10.3 Barg < P1 < 27.6 Barg)	Saturated			-15	S1R, S1S, S1RE, S1SE
	Superheated	✓	✓	—	-15, -EXT	S1S, S1HT, S1SE
		—	—	✓	-15, -35, -HTE	S1HT

CF = Consult Factory
N/R = Not Recommended

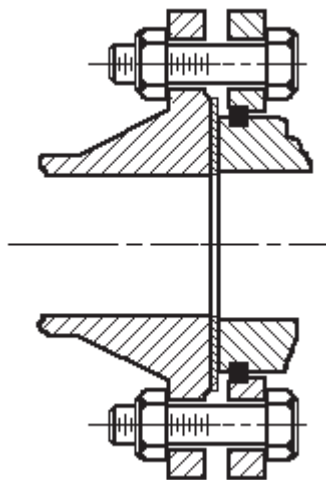
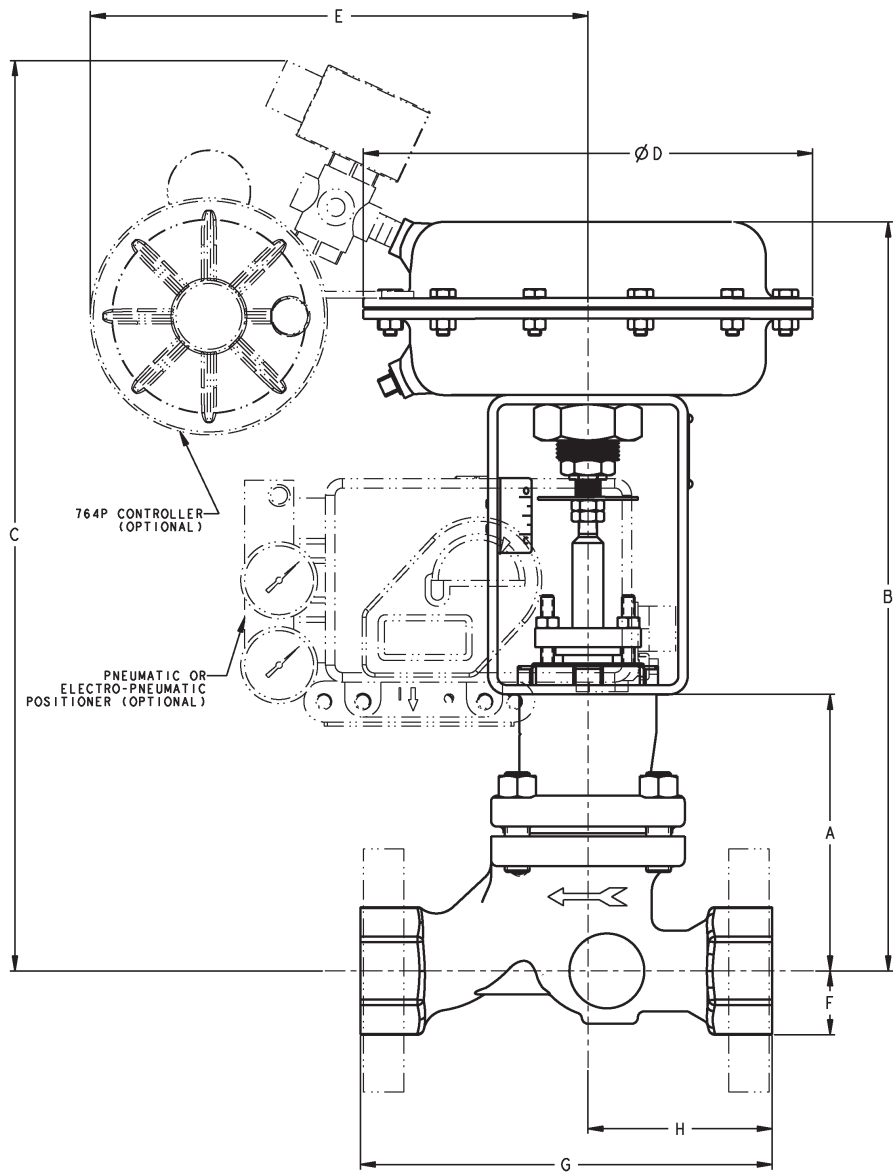

988 body with
flange bolt holes
drilled to mate to
DIN flange

FIGURE 9
DIN Flange

DIMENSIONS & WEIGHTS

ENGLISH UNITS – inch & lbs.			
Dimensions	Body Size		
	3/4" & 1"	1-1/2"	2"
A	5.54	5.91	6.86
B **	15.00	15.37	16.33
C ***	18.24	18.61	19.56
D	Model C27 Act. = 9.00 / Model C53 Act. = 11.56		
E	Model C27 Act. = 9.97 / Model C53 Act. = 11.21		
F	1.28	1.80	2.09
G ¹ NPT or SW	8.25	9.25	11.25
G ² Flanged *	8.50	9.50	11.50
H ¹	3.68	4.00	5.00
H ² Flanged	3.81	4.12	5.12
Wt. w C27 ****	26	30	42
Wt. w C53 ****	36	40	52

METRIC UNITS – mm & kgs.			
Dimensions	Body Size		
	DN20 & 25	DN40	DN50
A	140.7	150.1	174.2
B **	381.0	390.4	414.8
C ***	463.3	472.7	496.8
D	Model C27 Act. = 228.6 / Model C53 Act. = 293.6		
E	Model C27 Act. = 253.1 / Model C53 Act. = 284.7		
F	32.5	45.7	53.1
G ¹ NPT or SW	209.6	235.0	285.75
G ² Flanged *	215.9	241.3	292.1
H ¹	93.5	101.6	127.0
H ² Flanged	96.8	104.6	130.0
Wt. w C27 ****	11.8	13.6	19
Wt. w C53 ****	16.3	18.1	23.5

* Face-to-face dimensions per ISA 75.08.07.

** "B" dim for C53 Actuator add 0.14" (3.5mm).

*** "C" dim for C53 Actuator add 0.92" (23.4mm).

**** NPT Basic valve w/actuator weight, no accessories. Add 4lbs. (1.8kg) for positioner, Add 3 lbs (1.4kg) for limit switch, Add 15 lbs (6.8kg) for handwheel operator.

The contents of this publication are presented for informational purposes only, and while every effort has been made to ensure their accuracy, they are not to be construed as warranties or guarantees, express or implied, regarding the products or services described herein or their use or applicability. We reserve the right to modify or improve the designs or specifications of such product at any time without notice.

Cashco, Inc. does not assume responsibility for the selection, use or maintenance of any product. Responsibility for proper selection, use and maintenance of any Cashco, Inc. product remains solely with the purchaser.

MODEL 988 PRODUCT CODER 12/02/20

An "X" in POS 12 followed by a 5-digit control number overrides remaining selections.

86
POS 3 —
 POS 5
POS 6
POS 7
7
POS 10
POS 11
POS 12
POS 13
POS 14
POS 15
POS 16
POS 17
D

POSITION 3 - BODY/BONNET MATERIALS							
Body Size	CS	SST	H-C	CS	SST	CS	SST
	CODE	CODE	CODE	CODE	CODE	CODE	CODE
3/4"	A	R	H	3	5	N	W
1"	B	S	F	1	6	P	Y
1-1/2"	D	U	J	4	7	C	Z
2" *	E	V	K	2	8	T	&
Optional Const.	Standard			Opt-35 Hi-Temp **		Opt-40 Nace	

* Contact Cashco for assistance if your required pressure drop exceeds values in TB for Table 2 or Table 3.
** Select C27 Act. with 15-60 psig bench or C53 Act.

POSITION 5 - END CONNECTIONS				
Body Material	End Connection		Split Rings	
	Flanged		CS	SST
	Press. Cl.	Material	CODE	CODE
CS, SST, & H-C	150 #	CS	3	A
	300 #	CS	4	B
	PN 40	CS	7	E
SST & H-C	150 #	SST		C
	300 #	SST		D
	PN 40	SST		F
CS & SST	End Connection		CODE	
	NPT - Screwed		1	
		SW - Socketweld		2

POSITION 6 - TRIM MATERIALS					
Seat Design	Apply with these specific options are selected	PACKING LOADING DESIGN			
		Internal L-L		Extn'l L-L or Jammed **	
		Trim Design	CODE	Trim Design	CODE
Metal	—	S1S	A	S1SE	1
	—	S1R *	B	S1RE	2
	Opt-40	S40	C	S40E	3
	Opt-35	—	—	S1HT	4 ✓
	—	HC1	D	HC1E	5
Comp. / Soft	—	S3S	E	S3SE	6
	—	S3R	F	S3RE	7
	Opt-40	S40T	G	S40TE	8
	—	HC3	H	HC3E	9

* Base (Std) Trim
** Opt-34A/B/C or -38J ✓ Only trim when Opt-35 is selected

POSITION 7 - CHARACTER / PORT SIZE										
Trim Characteristic	Option Nos.	Available Body Sizes								
		All			3/4" & 1" Only					
		Port Size								
		Full	1-Step	2-Step	3-Step	4-Step	5-Step	6-Step	CODE	CODE
Equal %	None	A	B	E	F					
Linear	None	C	D	G	H	J	K	L		
Seat Design		Metal & Composition				Metal Only				
Equal %	* -15	M	N	T	U					
Linear	* -15	P	R	V	W	Y	Z	S		
Seat Design		Metal Only								

* Not suitable for NACE Service

POSITION 10 - PACKING									
Packing Option	Live-Loaded Option Nos.								
	Internal			External					
	Std	KRI	EXT	KRE	HTE-Lo	HTE-Hi * ✓			
	CODES								
	0	1	2	3	4	5			
Basic Pkg. Mat.	TFE	Dupont Kalrez	TFE	Dupont Kalrez	Carbon Graphite				
Packing Option	Non-Live Load Jammed Opt. Nos.								
	34A **	34B **		34C **		38J **			
	CODES								
	A	B		C		J			
W/ Opt-26	K	L		M					
Basic Pkg. Mat.	TFE								

* Select ONLY packing Opt-HTE when Opt-35 is selected. Requires use of positioner.
** Not for use with Internal L-L packing.
✓ Select for inlet pressures greater than 250 psig.

POSITION 11 - ACTUATOR MODEL / BENCH SET RANGE & ACTION				
Model	5-15 psig		15-60 psig	
	ATO FC	ATC FO	ATO FC	ATC FO
	CODE			
C27	A	1	B	2
C53	3	5	4	6
No Act. Body Assy only	0			

* Refer back to TB - Max. Pressure Drop Tables 2 & 3 to confirm selection of Act. Model with Port size Position 7 above.

POSITION 12 - 764P * (Bracket Mounted) - ADDITIONAL AIRSET (Bracket Mounted) - SOLENOID VALVE			
764P / Action	Solenoid Valve *** Exhaust on Deenergization		
	None	120VAC 60 Hz	24 VDC
	CODE		
None	0	6	C
Reverse **	2	8	E
Reverse W/ Airset **	3	9	F
Direct **	4	A	G
Direct W/ Airset **	5	B	H
Special Construction Contact Cashco for Code	X		

* Refer to 764-TB for Product Code of Controller.
** Select Code 1 on Position 13 if positioner is needed.
*** Solenoid rated as 4/4X only.

POSITION 14 - GAUGE BLOCK	
Option for Positioner	Code
None *	0
Gauge Block **	1

* For P5 gauge ports built in. No gauges.
* For D20 E, D3 E & PS2-3 gauge block is standard. No gauges.
** For D20 D, D20E & D20 A and PS2-1 & PS2-2 gauge block with gauges.
** For D3 X & D3 I gauge block only - no gauges.

POSITION 13 - DIRECT ACTING POSITIONER with AIRSET (Bracket Mounted) (3-15 psig) 4-20 mA Specify Split Range in Special Instructions on the P.O.						
Positioner Model	Ratings	Analogue/Digital	Hart	Fieldbus	Profibus	
		CODE				
P5 P/P *	Gen. Purpose	1				
D20 D I/P	Gen. Purpose	C	D			
D20 A I/P * ‡	Intrinsically Safe	2	5			
D20 E I/P *** ‡	Explosion Proof	E	F			
D3 X I/P	Gen. Purpose	L	M	N	P	
D3 I I/P	Intrinsically Safe	3	6	8	A	
D3 E I/P **** ‡	Explosion Proof	G	H	J	K	
PS2-1 I/P	Gen. Purpose	Q	R	S	T	
PS2-2 I/P	Intrinsically Safe	&	7	9	B	
PS2-3 I/P ***	Explosion Proof	<	U	V	W	
None **		0				

* Stock Item
** Actuator Assembly includes dimensions for (Namur) Mounting per IEC 60534-6-1.
*** D20E & PS2-3 are not available with limit/proximity switch option. Select codes "8", "9" or "0" in Pos. 15.
**** D3E Positioner is not available with options. Please select code "0" in Pos. 15.
‡ PMV Positioners are not FM Approved at this time. If you need FM Approval, please specify the Siemens PS2.

Алматы (7273)495-231
Ангарск (3955)60-70-56
Архангельск (8182)63-90-72
Астрахань (8512)99-46-04
Барнаул (3852)73-04-60
Белгород (4722)40-23-64
Благовещенск (4162)22-76-07
Брянск (4832)59-03-52
Владивосток (423)249-28-31
Владикавказ (8672)28-90-48
Владимир (4922)49-43-18
Волгоград (844)278-03-48
Вологда (8172)26-41-59
Воронеж (473)204-51-73
Екатеринбург (343)384-55-89

Иваново (4932)77-34-06
Ижевск (3412)26-03-58
Иркутск (395)279-98-46
Казань (843)206-01-48
Калининград (4012)72-03-81
Калуга (4842)92-23-67
Кемерово (3842)65-04-62
Киров (8332)68-02-04
Коломна (4966)23-41-49
Кострома (4942)77-07-48
Краснодар (861)203-40-90
Красноярск (391)204-63-61
Курск (4712)77-13-04
Курган (3522)50-90-47
Липецк (4742)52-20-81

Магнитогорск (3519)55-03-13
Москва (495)268-04-70
Мурманск (8152)59-64-93
Набережные Челны (8552)20-53-41
Нижний Новгород (831)429-08-12
Новокузнецк (3843)20-46-81
Ноябрьск (3496)41-32-12
Новосибирск (383)227-86-73
Омск (3812)21-46-40
Орел (4862)44-53-42
Оренбург (3532)37-68-04
Пenza (8412)22-31-16
Петрозаводск (8142)55-98-37
Псков (8112)59-10-37
Пермь (342)205-81-47

Ростов-на-Дону (863)308-18-15
Рязань (4912)46-61-64
Самара (846)206-03-16
Санкт-Петербург (812)309-46-40
Саратов (845)249-38-78
Севастополь (8692)22-31-93
Саранск (8342)22-96-24
Симферополь (3652)67-13-56
Смоленск (4812)29-41-54
Сочи (862)225-72-31
Ставрополь (8652)20-65-13
Сургут (3462)77-98-35
Сыктывкар (8212)25-95-17
Тамбов (4752)50-40-97
Тверь (4822)63-31-35

Тольятти (8482)63-91-07
Томск (3822)98-41-53
Тула (4872)33-79-87
Тюмень (3452)66-21-18
Ульяновск (8422)24-23-59
Улан-Уда (3012)59-97-51
Уфа (347)229-48-12
Хабаровск (4212)92-98-04
Чебоксары (8352)28-53-07
Челябинск (351)202-03-61
Череповец (8202)49-02-64
Чита (3022)38-34-83
Якутск (4112)23-90-97
Ярославль (4852)69-52-93

Россия +7(495)268-04-70 Казахстан +7(7172)727-132 Киргизия +996(312)96-26-47

<https://cashco.nt-rt.ru/> || coc@nt-rt.ru