



ISO Registered Company

# MODEL 987

## GLOBE-PATTERN CONTROL VALVE FOR GENERAL & CHEMICAL SERVICE



**MODEL 987**  
with Model C27 Actuator

### OVERVIEW

The Model 987 is a compact, economical, sliding stem, globe-style control valve designed primarily for general or chemical service. Use of investment body casting consolidates both carbon steel and stainless steel applications into the standard 316LSST (CF3M) material. The valve body and trim material is also available in Hastelloy C<sup>®</sup> construction.

Standard trim is metal seated design giving Class IV shutoff. Optional composition seat design gives Class VI shutoff. Available in body sizes 1/2" through 1" (DN15–DN25). End connections available: NPT, extended pipe nipples, flanged or flangeless.

### FEATURES

- All wetted trim components of 316L SST or Hastelloy C<sup>®</sup>.
- Flow-to-open design for increased:
  - rangeability,
  - maximized stability.
- High pressure drop capability.
- Standard TFE V-ring packing.
- Multiple reduced trim selections.
- Equal percent characterization.
- External corrosion protection.
- Field reversible actuator.
- Nace construction available.



### LINE SIZES AVAILABLE

1/2" (DN15), 3/4" (DN20) 1" (DN25)



### END CONNECTIONS

NPT, FLANGED, FLANGELESS,  
EXTENDED NIPPLES,



### COMMON APPLICATIONS

STEAM, AIR, OIL, WATER, INDUSTRIAL  
GASES



### DESIGN PRESSURE

MAXIMUM INLET:  
UP TO 1440 psig (99.3 Barg)

Алматы (7273)495-231  
Ангарск (3955)60-70-56  
Архангельск (8182)63-90-72  
Астрахань (8512)99-46-04  
Барнаул (3852)73-04-60  
Белгород (4722)40-23-64  
Благовещенск (4162)22-76-07  
Брянск (4632)59-03-52  
Владивосток (423)249-28-31  
Владикавказ (8672)28-90-48  
Владимир (4922)49-43-18  
Волгоград (844)278-03-48  
Вологда (8172)26-41-59  
Воронеж (473)204-51-73  
Екатеринбург (343)384-55-89

Иваново (4932)77-34-06  
Ижевск (3412)26-03-58  
Иркутск (395)279-98-46  
Казань (843)206-01-48  
Калининград (4012)72-03-81  
Калуга (4842)92-23-67  
Кемерово (3842)65-04-62  
Киров (8332)68-02-04  
Коломна (4966)23-41-49  
Кострома (4942)77-07-48  
Краснодар (861)203-40-90  
Красноярск (391)204-63-61  
Курск (4712)77-13-04  
Курган (3522)50-90-47  
Липецк (4742)52-20-81

Магнитогорск (3519)55-03-13  
Москва (495)268-04-70  
Мурманск (8152)59-64-93  
Набережные Челны (8552)20-53-41  
Нижний Новгород (831)429-08-12  
Новокузнецк (3843)20-46-81  
Ноябрьск (3496)41-32-12  
Новосибирск (383)227-86-73  
Омск (3812)21-46-40  
Орел (4862)44-53-42  
Оренбург (3532)37-68-04  
Пенза (8412)22-31-16  
Петрозаводск (8142)55-98-37  
Псков (8112)58-10-37  
Пермь (342)205-81-47

Ростов-на-Дону (863)308-18-15  
Рязань (4912)46-61-64  
Самара (846)206-03-16  
Санкт-Петербург (812)309-46-40  
Саратов (845)249-38-78  
Севастополь (8692)22-31-93  
Саранск (8342)22-96-24  
Симферополь (3652)67-13-56  
Смоленск (4812)29-41-54  
Сочи (862)225-72-31  
Ставрополь (8652)20-65-13  
Сургут (3462)77-98-35  
Сыктывкар (8212)25-95-17  
Тамбов (4752)50-40-97  
Тверь (4822)63-31-35

Тольятти (8482)63-91-07  
Томск (3822)98-41-53  
Тула (4872)33-79-87  
Тюмень (3452)66-21-18  
Ульяновск (8422)24-23-59  
Улан-Удэ (3012)59-97-51  
Уфа (347)229-48-12  
Хабаровск (4212)92-98-04  
Чебоксары (8352)28-53-07  
Челябинск (351)202-03-61  
Череповец (8202)49-02-64  
Чита (3022)38-34-83  
Якутск (4112)23-90-97  
Ярославль (4852)69-52-93

Россия +7(495)268-04-70

Казахстан +7(7172)727-132

Киргизия +996(312)96-26-47

## STANDARD / GENERAL SPECIFICATIONS

**Body Sizes:** 1/2", 3/4", and 1" (DN15, 20, 25).

**Body Materials:** SST: CF3M.  
HC: Ni-Mo-Cr Alloy "C" (Hastelloy C®).

**Body Pressure/ Temperature Rating:** Meets ANSI B16.34 for 150#/300#/600# pressure classes (SST). See Table 1.

**Max. Inlet Pressure:** SST: Up to 1440 psig (99.3 Barg).  
HC: Up to 1200 psig (82.7 Barg).

**Temperature Range:** -20°F to +450°F (-29°C to +232°C).

**End Connections:** F-to-F dimensions per ANSI/ISA S75.08.02, except with optional extended pipe nipples and flanged end connections. See dimensionals on page 11.  
Standard Female NPT – All sizes and body materials.  
Optional Flangeless - 3/4" and 1" (DN 20 & 25) body sizes only; all body materials. See Table 1 for body material vs. P vs. T vs. end connection. Flange surface finish to 250/125 micro-inch R<sub>a</sub> (equivalent to 250/125 AARH); suitable for use with spiral-wound metallic gaskets.  
Optional Extended Pipe Nipples – All sizes; SST body material only.

Opt-30 Flanged – CS or SST 150#, 300# or 600# RF flanges for use on SST body material only. F-to-F dimensions per ISA-S75.08.01.

**Max. Pressure Drop:** Up to 1440 psid (99.3 Bard). See Tables 2 and 3.

**Seat Leakage:** Meets ANSI/FCI 70-2.  
Metal Seated – Class IV.  
TFE Soft Seated – Class VI.

**Flow Direction:** Standard: Flow-to-Open (FTO). Minimizes packing sealing pressure level. (Not recommended for Flow-to-Close direction.)

**Inherent Flow Characteristic:** Equal Percent; FTO direction only.

**Flow Capacity:** Per ISA S75.11.01; see Tables 5 & 6.

Body		Port - Orifice			Max Cv	
inch	(DN)	Description	Size		Seat Design	
			inch	(mm)	Metal	Soft
1/2"	(15)	2-Step Reduced	0.375"	(9.5)	2.75	2.60
		3-Step Reduced	0.256"	(6.5)	1.10	NA
		4-Step Reduced	0.149"	(3.8)	0.50	NA
		5-Step Reduced	0.149"	(3.8)	0.30	NA
3/4"	(20)	1-Step Reduced	0.500"	(12.7)	4.13	4.13
		2-Step Reduced	0.375"	(9.5)	2.75	2.60
		3-Step Reduced	0.256"	(6.5)	1.10	NA
		4-Step Reduced	0.149"	(3.8)	0.50	NA
1"	(25)	5-Step Reduced	0.149"	(3.8)	0.30	NA
		Full	0.813"	(20.7)	6.95	6.70
		1-Step Reduced	0.500"	(12.7)	4.13	4.13
		2-Step Reduced	0.375"	(9.5)	2.75	2.60
		3-Step Reduced	0.256"	(6.5)	1.10	NA
		4-Step Reduced	0.149"	(3.8)	0.50	NA

NA = Not Available

**Actuator:** Multi-Spring-Diaphragm Type. Select "direct" or "reverse" action; field reversible.

ATC-FO = Air-to-Close, Fail Open.  
ATO-FC = Air-to-Open, Fail Close.

See Tables 2 and 3 for selection of correct actuator and the required bench set range spring.

**Painting:** Standard – All non corrosion resistant portions are powder coated per Spec. S-1743 and/or with corrosion resistant epoxy paint per Cashco Spec #S-1606.

Port Description	Rangeability
Full & 1-Step Reduced	50:1
2-Step Reduced	35:1
3-Step Reduced	35:1
4-Step Reduced	25:1
5-Step Reduced	25:1

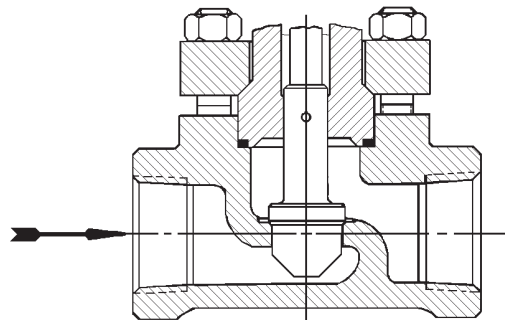

**FIGURE 1**  
Model 987- Full Port with Integral Metal Seat

## BODY SUB-ASSEMBLY SPECIFICATIONS

**Body/Bonnet** SST

**Materials:** HC - (Hastelloy C®).  
See Table 1 for specifications.

**Trim:** Function of packing design and body material.

Seat Design	Trim Designation #	Body Materials	Basic Trim Description
Metal	S1L	SST	316L SST
	HC1	H-C	Hastelloy C®
Composition Soft	S3L	SST	316LSST/TFE
	HC3	H-C	Hast. C/TFE

See Table 4 for trim material specifications.

<b>Gaskets:</b>	Standard - TFE O-ring.
<b>Stem Size:</b>	0.375" (9.52 mm) diameter, all body sizes.
<b>Packing:</b>	Standard TFE V-Ring.
<b>Bonnet Bolting:</b>	All materials. All standard and optional constructions. Studs: ASTM A193, Gr. B7. Nuts: ASTM A194, Gr. 2H.
<b>Packing Apparatus:</b>	Standard Flange - 316SST Follower - 316LSST

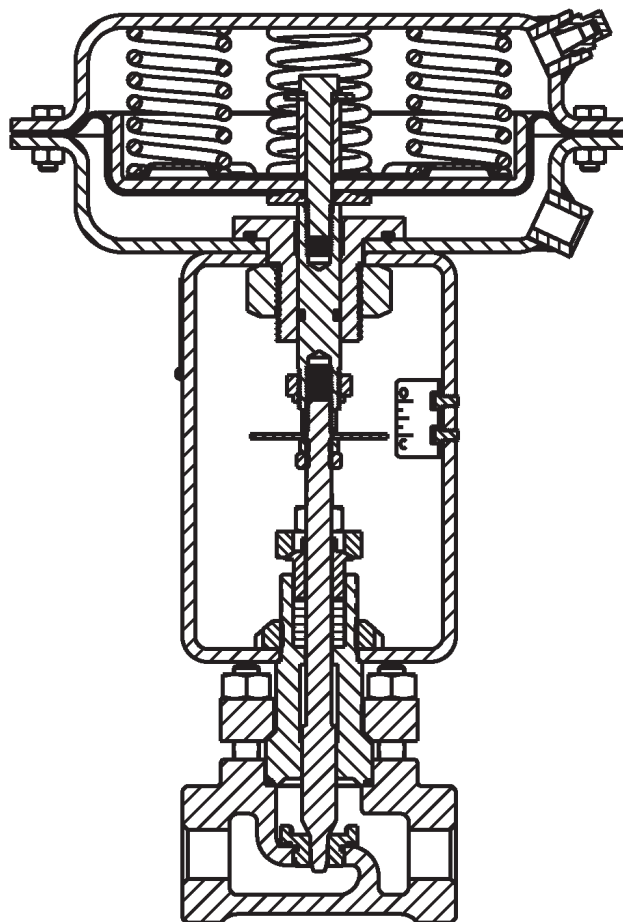

**FIGURE 2**

Model 987- Metal Seated with Reduced Port;  
Model C27 ATO-FC Actuator

## ACTUATOR SUB-ASSEMBLY SPECIFICATIONS

**Size, Stroke & Volumes:**

Basic Actuator		Dia-phragm Area		Nominal Stroke		Volumes			
						Clearance		Displacement	
Model	Action	in <sup>2</sup>	(cm <sup>2</sup> )	in	(mm)	in <sup>3</sup>	(cm <sup>3</sup> )	in <sup>3</sup>	(cm <sup>3</sup> )
C27	ATC	32	(209)	0.5	(12.7)	30.3	(496.5)	16.2	(265.5)
	ATO					28.2	(462.1)	16.4	(268.7)
C53	ATC	53	(342)	0.5	(12.7)	46.1	(755.4)	28.2	(462.1)
	ATO					44.3	(725.9)	24.7	(404.8)

**Ambient Temperature:** -50° to +180°F (-45° to +83°C).  
-20° to +140°F (-29° to +60°C) with electrical accessories.

**Bench Set & Max/Norm Pressures:**

Bench Range		Air Pressures			
psig	(Barg)	Normal Supply		Design Max.	
		psig	(Barg)	psig	(Barg)
5-15	(0.34-1.03)	20	(1.4)	100	(6.9)
15-60	(1.03-4.14)	75	(5.2)	100	(6.9)

**Materials:**

Part	Material
Diaphragm	Buna-N w/Polyester Insert
Lower & Upper Case, Yoke	Steel
Attachment Hub	17-4 PH SST
Stem	316/316L SST
Diaphragm Plate, Stem Spacer, Spring, Spring Plate, Hub Nut, Stem Bolt,	Steel
Diaphragm Washer	316/316L SST
Diaph. Washer O-ring, Hub O-ring, Stem O-ring	Buna-N
Bolts & Nuts	Steel Plated
Stem Lock Washer,	Steel

## OPTION SPECIFICATIONS

**Option -3:** **MANUAL HANDWHEEL.** Overrides the actuator spring force to allow manual stroking of the valve. Single acting design, side mounted handwheel. For ATO-FC action, handwheel operator “opens” the valve against spring force; may be utilized as a travel stop to prevent full closure. For ATC-FO action, handwheel operator “closes” the valve against spring force; may be utilized as a travel stop to prevent full opening.

**Option-7:** **LINE BOLTING.** For flangeless units only. See Figure 3.

Opt-7A: Heat treated, alloy steel studs per ASTM A193, Gr. B7; carbon steel nuts per ASTM A194, Gr.2H. Temperature Range:  $-20^{\circ} \leq T \leq 450^{\circ}F$  ( $-29^{\circ} \leq T \leq 232^{\circ}C$ ).

Opt-7C: Corrosion resistant, 18-8 SST (316SST) strain-hardened studs per ASTM A193, Gr. B8M; 18-8 SST nuts per ASTM A194, Gr. 8M. Temperature Range:  $-20^{\circ} \leq T \leq 450^{\circ}F$  ( $-29^{\circ} \leq T \leq 232^{\circ}C$ ).

**Option-15:** **STELLITED SEAT SURFACES.** Available only with metal seated trim designation S1L all port sizes. Both seating surface of plug and seat ring or integral seat are covered with Stellite #6 material. Recommended for flashing or partially cavitating service, or where extended time periods of ON-OFF or low flow (less than 10% open) operation occur and good shutoff is required.

**Option - 27:** **VISCOUS SERVICE BONNET.** Available on all materials. Two drilled passage-ways allow the fluid to bypass the guiding surface. To stabilize operation for fluids with viscosity greater than 100 Cp.

**Option-30:** **FLANGED END CONNECTIONS.** 150#, 300# or 600# RF flanges in CS or SST. Schedule 80 pipe nipple. Mating dimensions in accordance with ANSI B16.5.

**Option - 32:** **EXT. NIPPLE END CONNS.** ONLY available with CF3M SST body material. Pipe of 316LSST Schedule 80 material. Adds approximately 3 inches (76mm) to the face-to-face dimension of the standard unit.

**Option -40:** **NACE SERVICE.** Internal wetted portions meet NACE standard MR0175, when the exterior of the valve is not directly exposed to a sour gas environment, buried, insulated or otherwise denied direct atmospheric exposure. Apply in sour gas, sour crude, or service with hydrogen sulfide (H<sub>2</sub>S) in the flow mixture. Limits effects of sulfide stress corrosion cracking. Use with all body/bonnet materials, and with all trim designations. Not available with Option-15 Stellite Trim. Certificate of compliance supplied on request.

**Option -55:** **SPECIAL CLEANING.** Cleaned and packaged per Cashco Specification #S-1134. Suitable for Oxygen Service and other fluids. SST BODIES ONLY.

**Option -56:** **SPECIAL CLEANING.** Special cleaning procedure per Cashco Specification #S-1542. NOT for Oxygen Service. For all body materials.

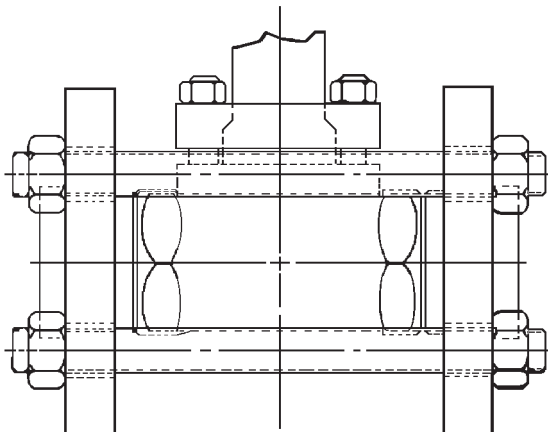

**Figure 3**  
Line Bolting

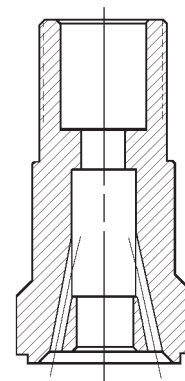

**Figure 4**  
Viscous Service Bonnet

## MOUNTED ACCESSORY SPECIFICATIONS

**Positioners:** *NOTE: PMV Positioners are not FM Approved at this time. If you need FM Approval, please specify the Siemens PS2.*

General: PMV Positioners. Aluminum housing with corrosion resistant powder coated epoxy. Pneumatic output load as required by actuator bench range. Field reversible action. Mounting dimensions per IEC 60534-6-1 Standard.

**P/P Pneumatic. Model P5** features SST cam with a simple cam locking device, tapped exhaust port for venting media, external zero adjustment. Input signal 3-15 psig, Includes gauge ports, no gauges. Analog only.

**I/P Electro-Pneumatic. Model D20** Digital or Hart compatible. Features single button self-calibration. input signal 4-20mA. Optional gauge block with gauges for Models D20 D and D20 A.

**Model D20 D** is general purpose.

**Model D20 A** is Intrinsically safe, Ex ia ATES.

**Model D20 E** is ATEX EEX d IIB+H<sub>2</sub>, T6 FM Approved.- **Approval Pending**  
Gauge block is built in, no gauges. Not available with limit switch option.

**Model D3** Digital, Hart, Profibus, or Fieldbus compatible. Input signal 4-20mA. Features large graphic display. Optional gauge block for Models D3 X and D3 I, no gauges.

**Model D3 X** is general purpose.

**Model D3 I** is Intrinsically safe, ATEX EEX ia IIC T4.

**Model D3 E** is ATEX EEX d IIB+H<sub>2</sub>, T6 CSA CLS 1 DIV 1

FM CLS 1 DIV 1 - **Approval Pending**

Gauge block is built in, no gauges. Not available with limit switch option.

**Model PS2** is Digital, Hart, Fieldbus and Profibus compatible. Input signal 4-20mA. Features a Makrolon housing, (Aluminum for Explosion Proof.) Mounting dimensions per IEC 60534-6-1 Standard.

**Model PS2-1** is general purpose.

**Model PS2-2** is Intrinsically safe, ATEX

Ex ia IIC T6/T4, FM CLS 1 DIV 1, CSA CLS 1 DIV 1, SIL 2  
**Model PS2-3** EX d IIC T6/T4, SIL 2 Not available with limit switch option.  
**All I/P positioners not available with 764's.**

**Air Tubing:** Instrument air tubing SST with SST fittings.

**Airset:** Model 5200P instrument air supply regulator. Use with positioners. Bracket mounted to actuator casing. Supplied with gauge. See technical bulletin 5200P-TB.

**Solenoid Valve:** Standard Brass: Available in standard weather-proof model. Brass body, 1/4" female NPT connections. Nipple mounted to actuator casing. 120 VAC, 60 Hz power supply, CSA Approved Class 3221-01, NEMA 2,3,3S,4,4X. 8" HF utilizes a direct mount NAMUR mount style.

X-Proof or SST construction: Consult Factory.

Standard installation vents actuator and drives valve to fail-safe position upon loss of electrical power.

Consult factory for 230/1/50, or 120 VDC power supplies, or intrinsically safe (IS) service.

**Transducers:** FM, CSA approved NEMA 4X Cl 1, Div 1 and Cl 1, Div 2

**Other Accessories:** 764 P/PD pressure controller. Lockup valve. Position transmitter.

**Limit Switches:** Model D20 and D3 positioners, switches are available, unit is enclosed in the positioner housing.

Limit and proximity switch options not available on Explosion proof rated positioners.

# TECHNICAL SPECIFICATIONS

TABLE 1 MATERIAL PRESSURE / TEMPERATURE RATINGS						
Body/Bonnet Materials		End Connection	English Units		Metric Units	
General	ASTM Spec.		Pressure psig	Temperature °F	Pressure (Barg)	Temperature (°C)
Cast Stainless Steel * (SST)	A351 Gr. CF3M/ A351, Gr. CF3M	150# SST Flanged or Flangeless	275	-20 to +100	(18.9)	(-29 to +38)
			235	200	(16.2)	(93)
			215	300	(14.8)	(148)
			195	400	(13.4)	(204)
			180	450	(12.4)	(232)
		150# Steel Flanged	285	-20 to +100	(19.6)	(-29 to +38)
			260	200	(17.7)	(100)
			230	300	(15.8)	(150)
			200	400	(13.8)	(200)
			185	450	(12.7)	(232)
		300# SST Flanged or Flangeless	720	-20 to +100	(49.6)	(-29 to +38)
			620	200	(42.7)	(93)
			560	300	(38.6)	(148)
			515	400	(35.5)	(204)
			495	450	(34.1)	(232)
		300# Steel Flanged	740	-20 to +100	(51.1)	(-29 to +38)
			680	200	(46.6)	(100)
			655	300	(45.1)	(150)
			635	400	(43.8)	(200)
			620	450	(42.7)	(232)
		NPT, Opt-32 or 600# Flanged or Flangeless	1440	-20 to +100	(99.3)	(-29 to +38)
			1240	200	(85.5)	(93)
			1120	300	(77.2)	(148)
			1025	400	(70.6)	(204)
990	450		(68.2)	(232)		
Cast Ni-Mo-Cr (HC)	A494, Gr. CW-12MW/ A574, Tp. C-22	150# Flangeless	230	-20 to +100	(15.8)	(-29 to +38)
			210	200	(14.4)	(93)
			200	300	(13.7)	(148)
			190	400	(13.1)	(204)
			180	450	(12.4)	(232)
		300# Flangeless	600	(-20 to +100)	(41.3)	(-29 to +38)
			550	200	(37.9)	(93)
			520	300	(35.8)	(148)
			475	450	(32.7)	(232)
			1200	-20 to +100	(82.7)	(-29 to +38)
		NPT or 600# Flangeless	1105	200	(76.2)	(93)
			1040	300	(71.7)	(148)
			950	450	(65.4)	(232)

\* Pressure Rating shall not exceed 375 psig (25.8 Barg) when body material is SST and process medium is oxygen. (CGA G-4.4 2012)

TABLE 2 - MAXIMUM PRESSURE DROP - PSID (BARD) CLASS IV SEAT LEAKAGE FOR METAL SEATED; CLASS VI SEAT LEAKAGE FOR COMPOSITION SEATED SHUTOFF PRESSURES MAY BE FURTHER DERATED BY MAWP										
LINE SIZE	PORT SIZE	ORIFICE SIZE		ACTUATOR			DIRECT ATO-FC & REVERSE ATC-FO			
		INCH	(mm)	MODEL NO.	BENCH RANGE		METAL SEAT		COMP SEAT	
					PSIG	(BARG)	PSID	(BARD)	PSID	(BARD)
1" (DN25)	FULL	0.813	(20.7)	C27	5-15	(0.34-1.03)	96	(6.6)	194	(13.4)
					15-60	(1.03-4.14)	682	(47.0)	400	(27.6)
				C53	5-15	(0.34-1.03)	288	(19.9)	387	(26.7)
					15-60	(1.03-4.14)	1258	(86.7)	400	(27.6)
3/4" - 1" (DN20 - DN25)	1 - STEP REDUCED	0.500	(12.7)	C27	5-15	(0.34-1.03)	454	(31.3)	400	(27.6)
					15-60	(1.03-4.14)	1440	(99.3)	400	(27.6)
1/2", 3/4", 1" (DN15, DN20, DN25)	2 - STEP REDUCED	0.375	(9.5)	C27	5-15	(0.34-1.03)	950	(65.5)	400	(27.6)
					15-60	(1.03-4.14)	1440	(99.3)	400	(27.6)
	3 - STEP REDUCED	0.256	(6.5)	C27	5-15	(0.34-1.03)	1440	(99.3)	N/A	N/A
					4 & 5 - STEP REDUCED	0.149	(3.8)	C27	5-15	(0.34-1.03)

- 1) CF = Consult Factory where differential pressures are below 50 psid preventing seat leakage evaluation per Cashco S-1597 at 50 psid.
- 2) Excessive differential pressures have been derated to the maximum allowable working pressure for each size at ambient conditions. Further derating may be necessary based on valve body pressure/temperature ratings.
- 3) ATC-FO values for 5-15 psig bench range based on maximum 20 psig (1.4 barg) supply pressure with use of a positioner. ATC FO values for 15-60 psig bench range based on maximum 75 psig (5.2 barg) supply pressure with use of a positioner.

**TABLE 3  
TRIM MATERIALS VS. DESIGNATION NOS.**

Part Description	METAL SEAT - Trim Designation Nos.	
	S1L*	HC1
Plug/Stem Assembly	316L SST	Hast C-22†
Seat Ring **	316L SST	Hast C-22†
Guide Bushing	Integral w/Bonnet	Integral w/Bonnet

Part Description	COMPOSITION/SOFT SEAT - Trim Designation Nos.	
	S3L	HC3
Plug/Stem Assembly	316L SST	Hast C-22†
Seat Ring **	316L SST	Hast C-22†
Guide Bushing	Integral w/Bonnet	Integral w/Bonnet
Seat Insert	TFE	TFE

Material	Material Specifications
316L SST	ASTM A479, Alloy S31603; Wrought Barstock, Annealed
† Hastelloy C-22®	ASTM A574, Alloy No6022; Wrought Barstock, Annealed
* Use S1L trim for Option-15 Stellite Seating Surfaces.	
** On Full Port Design - both Metal & Composition Seats, the seat ring is integral to the body.	

**TABLE 4  
FLOW CAPACITY - CV  
EQUAL PERCENT (=%) CHARACTER  
Cv @ 10% TRAVEL INCREMENTS  
METAL SEAT**

Body Size inch (DN)	Port Size Description	FL @ 10% Travel	Minimum Flow	Percent of Travel - %										FL @ 100% Travel
				10	20	30	40	50	60	70	80	90	100	
1" (25)	Full	.90	.14	.19	.40	.51	.61	.89	1.22	2.08	4.24	6.44	<b>6.95</b>	.90
3/4" & 1" (20 & 25)	1-Step Reduced	.90	.08	.12	.22	.29	.39	.51	.74	1.14	1.82	2.97	<b>4.13</b>	.90
1/2", 3/4" & 1" (15, 20 & 25)	2-Step Reduced	.90	.08	.10	.12	.15	.22	.32	.53	.91	1.62	2.37	<b>2.75</b>	.90
	3-Step Reduced	.90	.03	.04	.05	.06	.08	.12	.18	.31	.49	.74	<b>1.10</b>	.90
	4-Step Reduced	.90	.02	.03	.04	.05	.08	.09	.13	.19	.28	.41	<b>.50</b>	.90
	5-Step Reduced	.90	.01	.01	.01	.01	.02	.04	.07	.10	.15	.24	<b>.30</b>	.90

**TABLE 5  
FLOW CAPACITY - CV  
EQUAL PERCENT (=%) CHARACTER  
Cv @ 10% TRAVEL INCREMENTS  
COMPOSITION SOFT SEAT**

Body Size inch/(DN)	Port Size Description	FL @ 10% Travel	Minimum Flow	Percent of Travel - %										FL @ 100% Travel
				10	20	30	40	50	60	70	80	90	100	
1" (25)	Full	.90	.13	.29	.42	.56	.74	.91	1.20	2.17	4.36	5.87	<b>6.70</b>	.90
3/4" & 1" (20 & 25)	1-Step Reduced	.90	.08	.11	.14	.18	.28	.42	.67	1.12	1.91	3.14	<b>4.13</b>	.90
1/2", 3/4" & 1" (15, 20 & 25)	2-Step Reduced	.90	.12	.13	.14	.15	.16	.17	.29	.57	1.00	1.84	<b>2.60</b>	.90

**METRIC CONVERSION FACTOR: Cv / 1.16 = kv**

**TABLE 6  
APPLICATION RECOMMENDATIONS**

	Fluid	Options	Trim Designation Nos.
<b>GASES</b>	Inert Industrial (N <sub>2</sub> , He, Ar)	--	S1L, S3L
	Oxygen	OPT-55	S1L, S3L
	Hydrocarbons - Clean	OPT-40	ALL
	Hydrocarbons - Dirty	OPT-40	S1L
	Corrosive - Clean	OPT-40	ALL
	Corrosive - Dirty	OPT-15	S1L
<b>LIQUIDS</b>	Clean, Non-Cavitating, Non-Flashing	--	ALL
	Clean, Cavitating, Flashing	OPT-15	S1L
	NACE (H <sub>2</sub> S + HC's)	OPT-40	S1L
	Corrosive	OPT-40	ALL
	Abrasive	--	N/R
<b>STEAM</b>	P1 < 150 psig (P1, 10.3 Barg)	--	S1L
	Saturated 150 psig < P1 < 400 psig (10.3 Barg < P1 < 27.6 Barg)	OPT-15	S1L
	Superheated	NR	NR
	360°F < T1 < 450°F (182° C < T1 < 232° F)		

N/R = Not Recommended

**TABLE 7  
PIPING FLANGES FOR FLANGELESS VALVE CONNECTIONS**

Basic Flange	Flange Pressure Class		
	150#	300#	600#
Size			
1/2"	N/A	N/A	N/A
3/4"	N/A	√	√
1"	√	√	√
1" x 1/2" Reducing	√	√	√
1" x 3/4" Reducing	√	√	√
√ Available			

**FLANGE SIZE = PIPE SIZE = BODY SIZE**

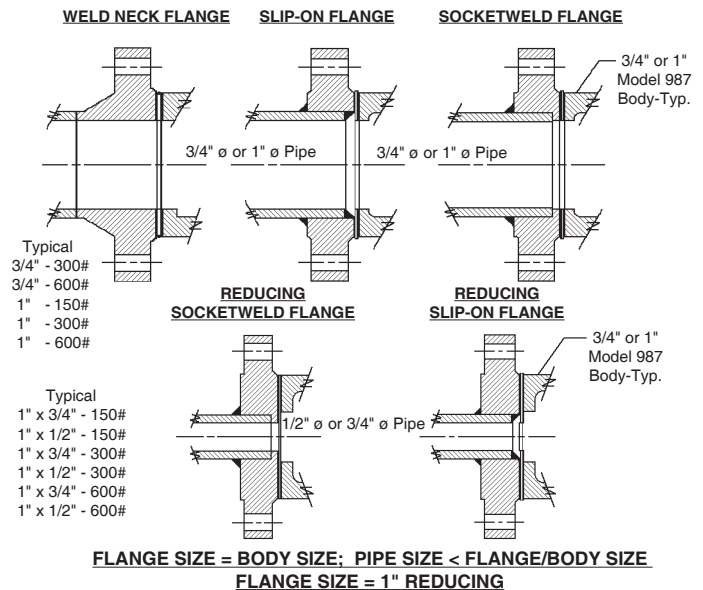

## DIMENSIONS & WEIGHTS

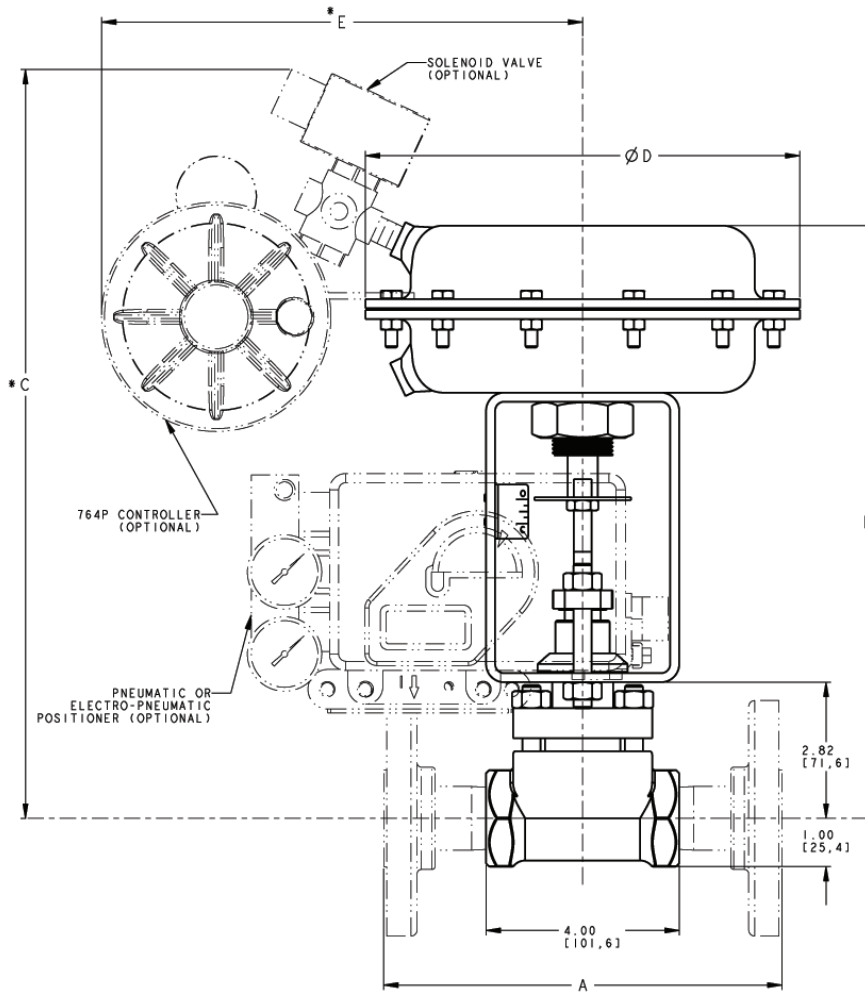

ENGLISH UNITS - inch & lbs.														
SIZE	Plain End Nipple A1	ANSI R.F.S.W.			ACTUATOR MODEL								Weight *	
		150#	300#	600#	C27				C53				C27	C53
					B	C	D	E	B	C	D	E		
1/2"	7.00	7.25	7.50	8.00	12.28	15.52	9.00	9.97	12.42	16.44	11.56	11.21	26	35
3/4"			7.62	8.12										
1"			7.75	8.25										

METRIC UNITS - mm & kgs.														
SIZE DN	Plain End Nipple A1	ANSI R.F.S.W.			ACTUATOR MODEL								Weight *	
		150#	300#	600#	C27				C53				C27	C53
					B	C	D	E	B	C	D	E		
15	177.8	184.2	190.5	203.2	312.0	394.2	228.6	253.1	315.5	417.6	293.6	284.7	11.7	15.8
20			193.5	206.2										
25			196.9	209.6										

\* Basic valve with actuator, no accessories or manual handwheel operator. Add for: positioner approx. 4# (1.8 kg); limit switch approx. 3# (1.4 kg); manual handwheel operator approx. 16# (7.2 kg); Flange ends approx. 11# (4.9kg).

# MODEL 987 PRODUCT CODER 12/02/20

An "X" in POS 12 followed by a 5-digit control number overrides remaining selections.

<b>CH</b>	POS 3	POS 5	POS 6	POS 7	<b>7</b>	POS 10	POS 11	POS 12	POS 13	POS 14	POS 15	POS 16	POS 17	<b>F</b>
-----------	-------	-------	-------	-------	----------	--------	--------	--------	--------	--------	--------	--------	--------	----------

POSITION 3 - SIZE			
Body Size	Material		Trim sizes
	SST	HC	
CODE			
1"	7	A	All
3/4"	8	B	1-Step Reduced & Lower
1/2"	9	C	2-Step Reduced & Lower

\* See Position 7

POSITION 5 - END CONNECTIONS					
End Connections					CODE
NPT Screwed					1
Extended Pipe Nipples, Opt-32 *					2
Flangeless without Line Bolting **					3
Pressure Class	Flanged End Connections, Opt-30 *		Body Size	Flangeless with Line Bolting, Opt-7	
	CS Flange	SST Flange		Flange Rating	Opt-7A Alloy Steel
CODE					
150 #	G	K	1"	150 #	A D
300 #	H	L		300 #	B E
600 #	N	M		600 #	4 6
				300 #	C F
600 #	N	M	3/4"	600 #	5 9

\* Available ONLY in SST Body Material. \*\* 3/4" & 1" Body. 'S.H. = Strain - Hardened.

POSITION 6 - BASIC MATERIALS		
Body Material	Trim Designation Nos.	
	S1L	HC1
CODE		
CF3M 316L SST	8	
CW-12MW (HC)		7
Composition Soft Seat		
CF3M (316LSST)	J	
CW-12MW (HC)		T
	S3L	HC3

POSITION 7 - PORT SIZE				
Seat	Max C <sub>v</sub>	Description	Applicable Valve Size	STD Flow Dir - FTO
CODE				
Metal	6.95	Full	1"	A
	4.13	1-Step Red.	3/4" & 1"	B
	2.75	2-Step Red.	All	C
	1.10	3-Step Red.	All	D
	.50	4-Step Red.	All	E
	.30	5-Step Red.	All	F
TFE-Soft	6.70	Full	1"	G
	4.13	1-Step Red.	3/4" & 1"	H
	2.60	2-Step Red.	All	J

POSITION 10 - TRIM OPTIONS				
Special Trim Options			Construction	
Opt-15 Stellite Plug & Seat *	Opt-27 Viscous Service Bonnet	Opt-15 & Opt-27 *	Std.	Nace Opt-40
CODE				
—	—	—	0	A
√	—	—	1	
—	√	—	4	B
—	—	√	5	

\* S1L trim designation only.

POSITION 11 - ACTUATOR MODEL / BENCH SET RANGE & ACTION				
Bench Range (psig)	Model C27		Model C53	
	ATO FC	ATC FO	ATO FC	ATC FO
CODE				
5-15	2	6	4	8
15-60	1	5	3	7

POSITION 13 - DIRECT ACTING POSITIONER with AIRSET (Bracket Mounted) (3-15 psig) 4-20 mA					
Specify Split Range in Special Instructions on the P.O.					
Positioner Model	Ratings	Analog/Digital	Hart	Fieldbus	Profibus
CODE					
P5 P/P *	Gen. Purpose	1			
D20 D I/P	Gen. Purpose	C	D		
D20 A I/P * ‡	Intrinsically Safe	2	5		
D20 E I/P *** ‡	Explosion Proof	E	F		
D3 X I/P	Gen. Purpose	L	M	N	P
D3 I I/P	Intrinsically Safe	3	6	8	A
D3 E I/P **** ‡	Explosion Proof	G	H	J	K
PS2-1 I/P	Gen. Purpose	Q	R	S	T
PS2-2 I/P	Intrinsically Safe	&	7	9	B
PS2-3 I/P ***	Explosion Proof	<	U	V	W
None **		0			

\* Stock Item  
 \*\* Actuator Assembly includes dimensions for (Namur) Mounting per IEC 60534-6-1.  
 \*\*\* D20E & PS2-3 are not available with limit/proximity switch option. Select codes "8", "9" or "0" in Pos. 15.  
 \*\*\*\* D3E Positioner is not available with options. Please select code "0" in Pos. 15.  
 ‡ PMV Positioners are not FM Approved at this time. If you need FM Approval, please specify the Siemens PS2.

POSITION 12 - 764P * (Bracket Mtd) -ADDITIONAL Airset (Bracket Mtd) - SOLENOID VALVE			
764P / Action	Solenoid Valve *** Exhaust on Deenergization		
	None	120VAC 60 Hz	24 VDC
CODE			
None	0	6	C
Reverse **	2	8	E
Reverse W/ Airset **	3	9	F
Direct **	4	A	G
Direct W/ Airset **	5	B	H
Special Construction Contat Cashco for Code	X		

\* Refer to 764-TB for Product Code of Controller.  
 \*\* Select Code 1 on Position 13 if positioner is needed.  
 \*\*\* Solenoid rated as 4/4X only.

POSITION 14 - GAUGE BLOCK	
Option for Positioner	Code
None *	0
Gauge Block **	1

\* For P5 gauge ports built in. No gauges.  
 \* For D20 E, D3 E & PS2-3 gauge block is standard. No gauges.  
 \*\* For D20 D, D20E & D20 A and PS2-1 & PS2-2 - gauge block with gauges.  
 \*\* For D3 X & D3 I gauge block only - no gauges.

POSITION 16 - OPTIONS	
Accessories	CODE
No Handwheel	0
Handwheel *	9

\* Not available with Positioner Option. Select code 0 in Pos. 13.

POSITION 15 - POSITIONER OPTIONS							
Options	POSITIONERS			I/P TRANSDUCERS *			
	1 Inductive Limit Switches	1 Micro-switches Limit Switches	Position Transmitter	3-15 PSIG No Airset **	3-15 PSIG W/ Airset **	0-60 PSIG No Airset ***	0-60 PSIG W/ Airset ***
CODE							
P5				4	5		
D3 & D20 <sup>2</sup>	7	T	9				
PS2			8				
No Positioner				C	F	R	S
None		0					

\* For 0-60 Psig Transducer please contact the factory.  
 \*\* If 5-15 psig Bench Range is selected in Pos. 11, codes R & S are invalid options.  
 \*\*\* If 15-60 psig Bench Range is selected in Pos. 11, codes 4, 5, C & F are invalid options.  
<sup>1</sup> D20E & PS2-3 are not available with limit/proximity switch option. Select codes "8", "9" or "0".  
<sup>2</sup> D3E Positioner is not available with options. Please select code "0".

POSITION 17 - CLEANING & PAINTING			
Painting	Standard Cleaning	Cleaned to Spec. #S-1542 Opt-56	Cleaned to Spec. #S-1134 * (O <sup>2</sup> Cleaned) Opt-55
	Option	CODE	
Standard	—	0	3 6

\* SST Bodies Only. Cleaned for Oxygen Service.

Алматы (7273)495-231  
Ангарск (3955)60-70-56  
Архангельск (8182)63-90-72  
Астрахань (8512)99-46-04  
Барнаул (3852)73-04-60  
Белгород (4722)40-23-64  
Благовещенск (4162)22-76-07  
Брянск (4832)59-03-52  
Владивосток (423)249-28-31  
Владикавказ (8672)28-90-48  
Владимир (4922)49-43-18  
Волгоград (844)278-03-48  
Вологда (8172)26-41-59  
Воронеж (473)204-51-73  
Екатеринбург (343)384-55-89

Иваново (4932)77-34-06  
Ижевск (3412)26-03-58  
Иркутск (395)279-99-46  
Казань (843)206-01-48  
Калининград (4012)72-03-81  
Калуга (4842)92-23-67  
Кемерово (3842)65-04-62  
Киров (8332)68-02-04  
Коломна (4966)23-41-49  
Кострома (4942)77-07-48  
Краснодар (861)203-40-90  
Красноярск (391)204-63-61  
Курск (4712)77-13-04  
Курган (3522)50-90-47  
Липецк (4742)52-20-81

Магнитогорск (3519)55-03-13  
Москва (495)268-04-70  
Мурманск (8152)59-64-93  
Набережные Челны (8552)20-53-41  
Нижний Новгород (831)429-08-12  
Новокузнецк (3843)20-46-81  
Ноябрьск (3496)41-32-12  
Новосибирск (383)227-86-73  
Омск (3812)21-46-40  
Орел (4862)44-53-42  
Оренбург (3532)37-68-04  
Пенза (8412)22-31-16  
Петрозаводск (8142)55-98-37  
Псков (8112)59-10-37  
Пермь (342)205-81-47

Ростов-на-Дону (863)308-18-15  
Рязань (4912)46-61-64  
Самара (846)206-03-16  
Санкт-Петербург (812)309-46-40  
Саратов (845)249-38-78  
Севастополь (8692)22-31-93  
Саранск (8342)22-96-24  
Симферополь (3652)67-13-56  
Смоленск (4812)29-41-54  
Сочи (862)225-72-31  
Ставрополь (8652)20-65-13  
Сургут (3462)77-98-35  
Сыктывкар (8212)25-95-17  
Тамбов (4752)50-40-97  
Тверь (4822)63-31-35

Тольятти (8482)63-91-07  
Томск (3822)98-41-53  
Тула (4872)33-79-87  
Тюмень (3452)66-21-18  
Ульяновск (8422)24-23-59  
Улан-Уда (3012)59-97-51  
Уфа (347)229-48-12  
Хабаровск (4212)92-98-04  
Чебоксары (8352)28-53-07  
Челябинск (351)202-03-61  
Череповец (8202)49-02-64  
Чита (3022)38-34-83  
Якутск (4112)23-90-97  
Ярославль (4852)69-52-93

Россия +7(495)268-04-70

Казахстан +7(7172)727-132

Киргизия +996(312)96-26-47

<https://cashco.nt-rt.ru/> || [coc@nt-rt.ru](mailto:coc@nt-rt.ru)