



ISO Registered Company

MODEL POSR-2

PRESSURE REDUCING REGULATOR PILOT OPERATED



MODEL POSR-2

OVERVIEW

The Model POSR-2 is a pilot operated regulator primarily for use with steam. The external pilot valve is supplied from a main valve body tapped connection. Sizes are 1/2", 3/4", 1", 1-1/4", 1-1/2", 2", 3" and 4" (DN15, 20, 25, 32, 40, 50, 80 and 100). Handles pressure drops up to 200 psi (13.8 Bar) with adjustable outlet pressures between 5 and 150 psig (.34 and 10.3 Barg).

FEATURES

- Hardened Trim:** Hardened pilot and main valve trim for long life.
- Bellows Seal:** The pilot uses a bellows as a frictionless seal for the pilot valve plug. It was incorporated to insure that the pilot maintains its sensitivity and smooth operation in older steam systems that are chemically treated and systems that are used intermittently. Prevents common "sticking" of pilot valve.
- High Sensitivity:** Four pilot range springs provide high sensitivity and contribute to the valve's excellent stability.
- Two Body Materials:** Ductile Iron or cast Steel.
- Easy to Install:** A 1/4" (DN8) NPT sensing line and the valve body are the only connections required.



LINE SIZES AVAILABLE

1/2" (DN15), 3/4" (DN20), 1" (DN25), 1-1/4" (DN32), 1-1/2" (DN40), 2" (DN50), 3" (DN80), 4" (DN100)



END CONNECTIONS

NPT, FLANGED, FLAT FACED, RAISED FACED



COMMON APPLICATIONS

STEAM DISTRIBUTION SYSTEMS



DESIGN PRESSURE

INLET: UP TO 300 psig (20.7 Barg)
OUTLET: 5-150 psig (0.34-10.3 Barg)

Алматы (7273)495-231
 Ангарск (3955)60-70-56
 Архангельск (8182)63-90-72
 Астрахань (8512)99-46-04
 Барнаул (3852)73-04-60
 Белгород (4722)40-23-64
 Благовещенск (4162)22-76-07
 Брянск (4832)59-03-52
 Владивосток (423)249-28-31
 Владикавказ (8672)28-90-48
 Владимир (4922)49-43-18
 Волгоград (844)278-03-48
 Вологда (8172)26-41-59
 Воронеж (473)204-51-73
 Екатеринбург (343)384-55-89

Иваново (4932)77-34-06
 Ижевск (3412)26-03-58
 Иркутск (395)279-98-46
 Казань (843)206-01-48
 Калининград (4012)72-03-81
 Калуга (4842)92-23-67
 Кемерово (3842)65-04-62
 Киров (8332)68-02-04
 Коломна (4968)23-41-49
 Кострома (4942)77-07-48
 Краснодар (861)203-40-90
 Красноярск (391)204-63-61
 Курск (4712)77-13-04
 Курган (3522)50-90-47
 Липецк (4742)52-20-81

Магнитогорск (3519)55-03-13
 Москва (495)268-04-70
 Мурманск (8152)59-64-93
 Набережные Челны (8552)20-53-41
 Нижний Новгород (831)429-08-12
 Новокузнецк (3843)20-46-81
 Ноябрьск (3496)41-32-12
 Новосибирск (383)227-86-73
 Омск (3812)21-46-40
 Орел (4862)44-53-42
 Оренбург (3532)37-68-04
 Пенза (8412)22-31-16
 Петрозаводск (8142)55-98-37
 Псков (8112)59-10-37
 Пермь (342)205-81-47

Ростов-на-Дону (863)308-18-15
 Рязань (4912)46-61-64
 Самара (846)206-03-16
 Санкт-Петербург (812)309-46-40
 Саратов (845)249-38-78
 Севастополь (8692)22-31-93
 Саранск (8342)22-96-24
 Симферополь (3652)67-13-56
 Смоленск (4812)29-41-54
 Сочи (862)225-72-31
 Ставрополь (8652)20-65-13
 Сургут (3462)77-98-35
 Сыктывкар (8212)25-95-17
 Тамбов (4752)50-40-97
 Тверь (4822)63-31-35

Тольятти (8482)63-91-07
 Томск (3822)98-41-53
 Тула (4872)33-79-87
 Тюмень (3452)66-21-18
 Ульяновск (8422)24-23-59
 Улан-Удэ (3012)59-97-51
 Уфа (347)229-48-12
 Хабаровск (4212)92-98-04
 Чебоксары (8352)28-53-07
 Челябинск (351)202-03-61
 Череповец (8202)49-02-64
 Чита (3022)38-34-83
 Якутск (4112)23-90-97
 Ярославль (4852)69-52-93

Россия +7(495)268-04-70

Казахстан +7(7172)727-132

Киргизия +996(312)96-26-47

STANDARD/GENERAL SPECIFICATIONS

Body Sizes: 1/2", 3/4", 1", 1-1/4", 1-1/2", 2", 3" and 4"
(DN15, 20, 25, 32, 40, 50, 80 and 100).

End Connections: NPT – Body sizes 1/2", 3/4", 1", 1-1/4", 1-1/2" and 2"
F-to-F-dim. per ISA S75.08.03

Flanged – **DI Body:** 125# FF/250# RF
Integral – 1-1/2", 2", 3" and 4"
- **CS Body:** 150# RF/300# RF
Separable – 1", 1-1/2", 2", 3"
Integral – 4"

Ductile Iron material with NPT conn. meets dimensional requirements for ASME B16.4 for 250# pressure class.
With 125# or 250# flange conn. meets dimensional requirements for ASME B16.1.

Carbon Steel material meets ASME B16.34 for 150# or 300# pressure classes, and meets 300# pressure class for NPT conn.

See Tables 6, 7 and 8 for F-to-F-dim. - 250# and 300# flanges per ISA S75.08.01. 125# and 150# flanges not standard.

**Main Valve Body/
Bonnet/Cyl./
Head** — DI/DI/SST/CS — DI/CI
CS/DI/SST/CS — DI/CI
CS/DI/SST/CS — DI/CS

**Pilot Body/
Spring Chamber** DI = Ductile Iron /
CS = Carbon Steel
CI = Cast Iron
Materials Combinations: SST = Stainless Steel
See Table 1 for materials specifications.

Max. Inlet Pressure: DI - Up to 250 psig (17.2 Barg)
CS - Up to 300 psig (20.7 Barg)
Function of end Conn. See Table 1.

Max. Temperature: Up to 450°F (232°C) @ inlet.

Outlet Pressure: 5–150 psig (.34–10.3 Barg) in four range springs. See Table 2.

Pressure Drop: Maximum – 200 psid (13.8 Bard).
Minimum – Standard - 15 psid (1.0 Bard) for 1/2" thru 2" (DN15 thru 50) sizes. 20 psid (1.3 Bard) for 3" and 4" (DN80 and 100) sizes.
Low - 5 psid (0.3 Bard) for all sizes.

Capacity – Cv:

Body Size		Max Cv
In	(DN)	
1/2"	(15)	6.9
3/4"	(20)	8.7
1"	(25)	11
1-1/4" & 1-1/2"	(32 & 40)	20
2"	(50)	39
3"	(80)	66
4"	(100)	88

See Table 5 for capacity in #/Hr at various pressure conditions.
See Table 4 for wide open Cv's and orifice size; use for safety relief valve sizing.

Seat Leakage: Class IV per ANSI/FCI 70-2.

Painting: Standard: All non-corrosion resistant portions to be painted with corrosion resistant epoxy paint per Cashco Spec #S-1606.

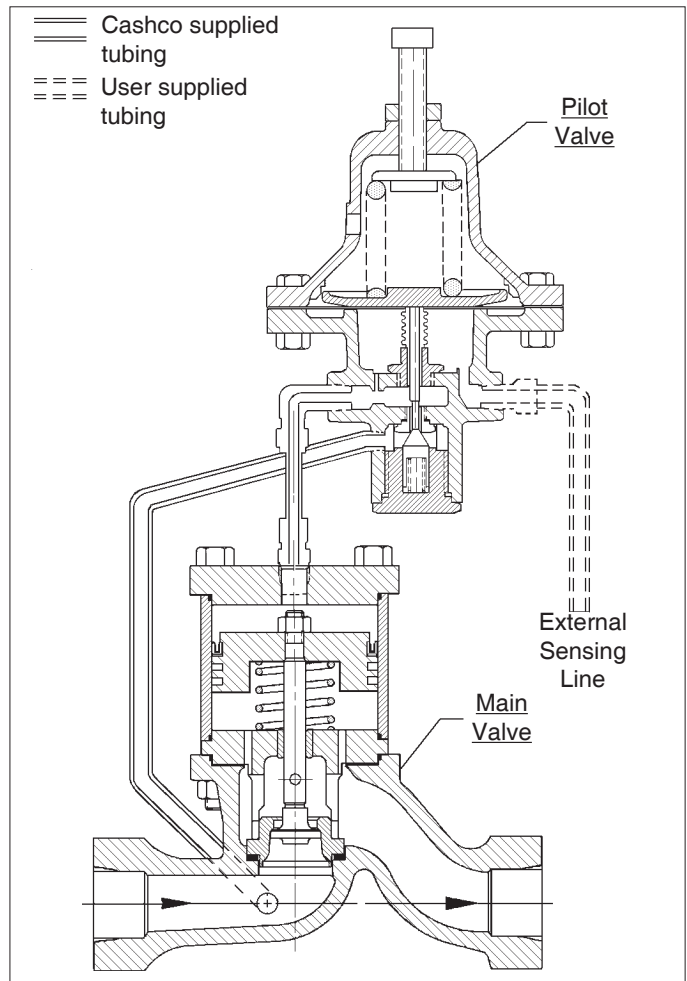

FIGURE 1: POSR-2

MAIN VALVE MATERIAL SPECIFICATIONS

Body:	DI – ASTM A395. CS – ASTM A216, Gr. WCB.	Orientation:	Three possible arrangements, dependent on flow direction. See Figure 2.
Bonnet:	DI – ASTM A395. NOTE: Cage integral with bonnet.	Cylinder/Bonnet Bolting:	CS, zinc plated.
Cylinder:	SST – ASTM A269. Interior surface coated with salt nitrided melonite, mechanically polished.	Gaskets:	<u>Seat ring</u> – 304 SST/carbon <u>Cylinder</u> – TFE
Head:	CS – ASTM A516, Gr. 70	Piping Inter-connectors:	<u>Pipe</u> – CS, Schedule 80; ASTM A53, Gr. B, or ASTM A106, Gr. B. <u>Fittings:</u> Malleable iron, Class 300.
Trim:	Trim designation number S2; see Table 3.	Tube and Fittings:	<u>Tube:</u> Annealed copper, 1/4" OD, 0.030 inch wall thickness. <u>Fittings:</u> Brass, 1/4" Tube x 1/4" NPT

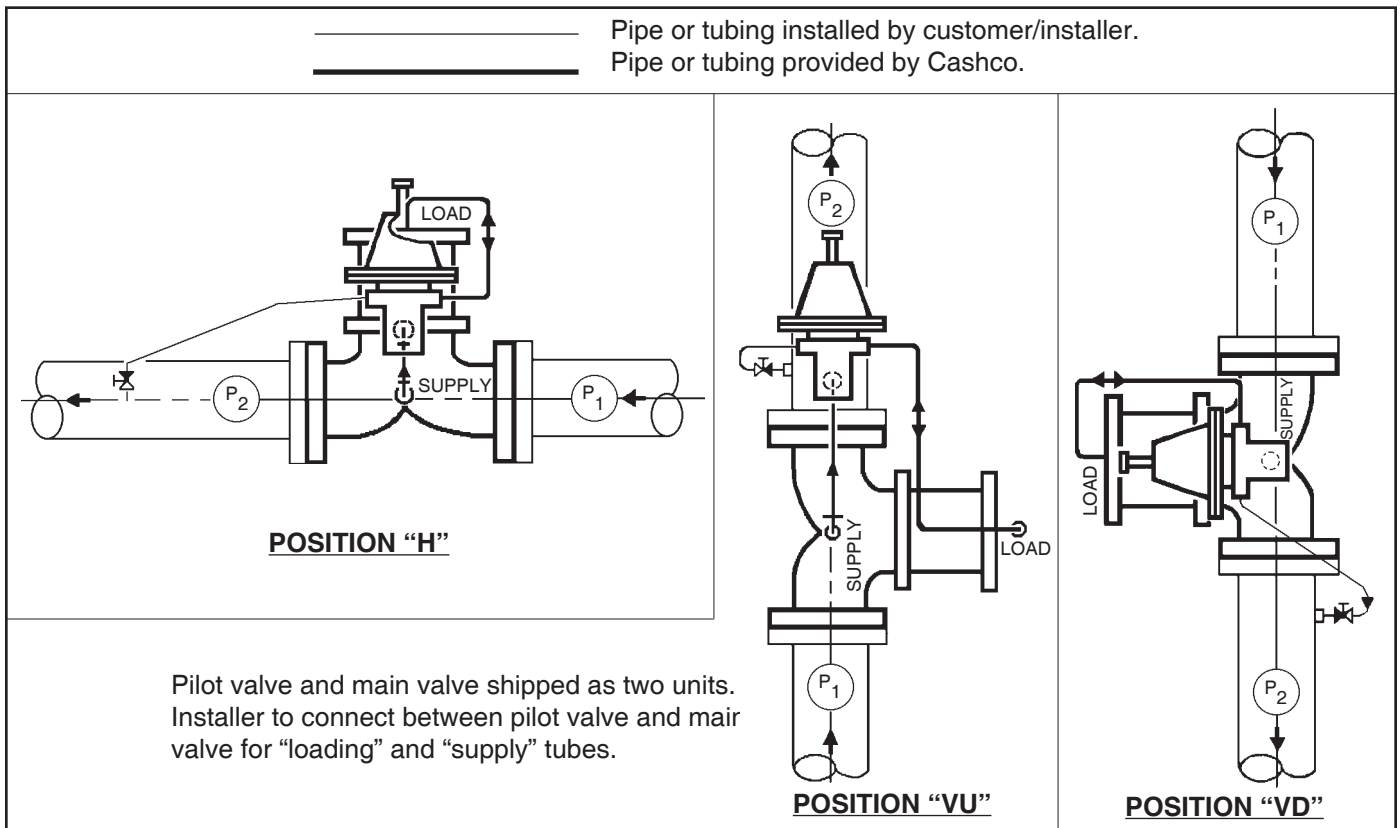

FIGURE 2
Orientation/Arrangement

PILOT VALVE MATERIAL SPECIFICATIONS

Body:	DI – ASTM A395.	Trim:	Trim designation number S2; see Table 3.
Spring Chamber:	CI – ASTM A126, Cl. B. CS – ASTM A216, Gr. WCB.	Gaskets:	<u>Seat ring</u> – Annealed copper. <u>Diaphragm</u> – Aramid/SBR; non-asbestos.

Body Cap:	SST – ASTM A582, Type 416.	Spring Button:	Cl.
Range Spring:	Heat treated CS, zinc plated.	Pressure Plate:	Cl.
Adjusting Screw & Lock Nut:	CS, zinc plated.		

OPTION SPECIFICATIONS

Option -3:	<u>HAND WHEEL & LOCKING LEVER.</u> Utilize when pressure setting changes are frequent.
Option-25:	<u>TAPPED VENT.</u> 1/8" (DN6) NPT tapped opening in spring chamber for piping vent to remote location, in the event of diaphragm failure.
Option-25S:	<u>SST RAIN PROOF BUG VENT:</u> (For Opt-25).
Option-56:	<u>SPECIAL CLEANING.</u> Cleaning per Cashco Spec #S-1542. Higher degree of cleaning than the standard commercial cleaning.

PRINCIPLES OF OPERATION

The POSR-2 pilot obtains its operating medium from the main valve body inlet. Downstream pressure P_2 registers on the underside of the main valve's piston and the pilot valve's diaphragm.

The loading pressure on the main valve's piston is higher than the downstream P_2 pressure by the sum of the pressures required to overcome the main valve's unbalance plug force and the piston spring's force.

The pilot has a downstream bleed orifice that bleeds part of the loading medium downstream. In operation, the pilot valve's plug can flow more medium than is bled downstream. This increases the loading pressure on the main valve's piston which increases the opening of the valve's plug. Partially closing the pilot valve's plug will reduce its flow to less than the amount bleeding downstream, and allows the loading pressure on the main valve's piston to decay, allowing partial closing of the main valve's plug.

The pilot valve's diaphragm senses the downstream P_2 pressure and compares the force generated to the force developed by the pilot's range spring.

If during operation the downstream P_2 pressure falls

below the set point, the main valve's piston senses the reduced pressure on its underside and instantly moves down. This increases the flow through the main valve's plug. At the same time, the pilot senses the reduced pressure and the pilot valve's plug increases its opening. This action elevates the loading pressure on the upper side of the main valve's piston, opens the main valve's plug more and increases flow enough to restore the downstream P_2 pressure to the set point.

If the downstream P_2 pressure rises above the set point, the force developed by the increased pressure on the underside of the piston instantly moves it upward and partially closes the main valve's plug. Meanwhile, the pilot valve's plug partially closes and allows the loading pressure to decay. The reduced loading pressure on the upper side of the piston closes the main valve's plug enough to restore the downstream P_2 pressure to the setpoint.

Pressure setpoint is adjusted by changing the compression of the pilot's range spring. Compressing the range spring will increase the downstream P_2 pressure. Relaxing the range spring decreases the downstream P_2 pressure. See Figure 3.

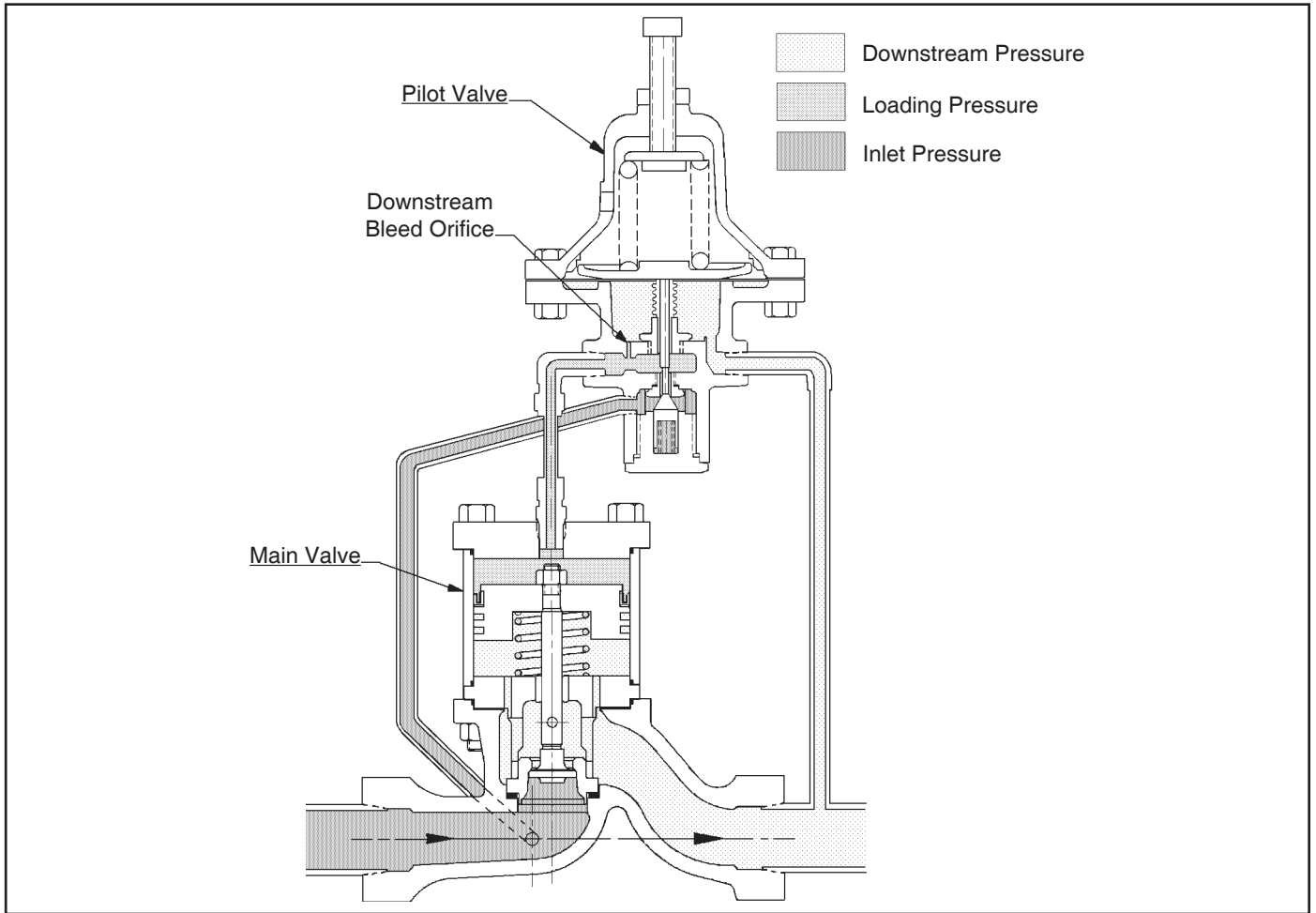

FIGURE 3:

TECHNICAL SPECIFICATIONS

TABLE 1 DESIGN PRESSURE-TEMPERATURE MATERIAL SPECIFICATIONS

Material Specifications				Main Valve End Conns.	Inlet				Outlet					
									* Operating Pressure		** Emergency Overpressure			
Main Valve		Pilot Valve			Spring Range		10–40 psig 30–80 psig 70–150 psig		5–15 psig					
Descrip. (Abbr.)	ASTM No.	Descrip. (Abbr.)	ASTM No.	psig	(Barg)	°F	(°C)	psig	(Barg)	psig	(Barg)			
DI/DI/SST/CS	A395/ A395/ A269/ A516, Gr. 70	DI/CI	A395/ A126, Cl. B	125# Flgd.	145	(10.0)	375	(191)	1.10 x UVRS up to 125 psig (up to 8.6 Barg)	145	(10.0)	100	(6.9)	
					140	(9.7)	400	(205)		140	(9.7)	100	(6.9)	
					130	(9.0)	425	(219)		130	(9.0)	100	(6.9)	
					125	(8.6)	450	(232)		125	(8.6)	100	(6.9)	
		250# Flgd. or NPT	270	(18.6)	425	(219)	1.10 x UVRS up to 150 psig (up to 10.3 Barg)	150	(10.3)	100	(6.9)			
			250	(17.2)	450	(232)								
CS/DI/SST/CS	A216, Gr. WCB/ A395/ A269/ A516, Gr. 70	DI/CI	A395/ A126, Cl. B	150# Flgd.	200	(13.8)	400	(205)	1.10 x UVRS up to 150 psig (up to 10.3 Barg)	150	(10.3)	100	(6.9)	
		DI/CS	A395/A216, Gr. WCB		185	(12.7)	450	(232)		200	(13.8)			
		DI/CI	A395/ A126, Cl. B		300# Flgd. or NPT	300	(20.7)	450		(232)	150	(10.3)	100	(6.9)
		DI/CS	A395/ A216, Gr. WCB		300# Flgd. or NPT	300	(20.7)	450		(232)	200	(13.8)	100	(6.9)

* Limit is the lower pressure value of 125/150 psig (8.6/10.3 Barg), or the factor x UVRS (UVRS = "Upper Value of Range Spring). Example: Steel body – for a 30-80 psig (2.1–5.5 Barg) standard range spring, the 1.10 x UVRS value = 1.10 x 80 = 88 psig; 88 < 150, therefore pressure limit = 88 psig (1.10 x 5.5 = 6.1 Barg; 6.1 < 10.3, therefore pressure limit = 6.1 Barg).

** Emergency Overpressure. Safety relief valve $P_{\text{setpoint}} + P_{\text{accumulation}}$ must not exceed this pressure level.

NOTE: All outlet temperature levels are thermodynamically determined by the maximum inlet pressure/temperature conditions.

**TABLE 2
RANGE SPRINGS**

Outlet Range		Emergency Overpressure
psig	(Barg)	psig (Barg)
5-15	(.34-1.03)	100 (6.9)
10-40	(.69-2.8)	200 (13.8)
30-80	(2.1-5.5)	
70-150	(4.8-10.3)	

**TABLE 3
TRIM MATERIALS**

Part	SST Trim Designation Number		Part
	Main Valve	Pilot Valve	
	S2	S2	
Plug/Stem	17-4 PH Cond. H-1075 RC ≈ 32-35	Hardened 416 SST RC ≈ 35-39	Plug/Stem
			Stem Extension
Seat Ring	Hardened 416 SST RC ≈ 35-39	Hardened 416 SST Rc ≈ 35-39	Seat Ring
Piston	Brass	302 SST	Diaphragm
Piston Spring	17-4 PH SST	302 SST	Piston Spring
Piston Seal	SST / TFE	Brass	Bellows Assembly
Stem Nut	CS, Zinc Plated		
Stem Guide	17-4 PH Cond. H-1075	316 SST	Screen
		18-8 SST	Bleed Orifice

NOTE: Cashco, Inc. does not recommend metal seated trim on any service where the flow will be dead ended down stream of the pressure reducing regulator.

**TABLE 4
WIDE OPEN CAPACITY – MAX Cv
(Use for Safety Relief Valve Sizing)**

Body Size		Orifice Size		Max Cv
in	(DN)	in	(mm)	
1/2"	(15)	.75	(19)	6.9
3/4"	(20)	.75	(19)	8.7
1"	(25)	.75	(19)	11
1-1/4" & 1-1/2"	(32 & 40)	1.25	(32)	20
2"	(50)	1.75	(44)	39
3"	(80)	2.50	(64)	66
4"	(100)	2.88	(73)	88

METRIC CONVERSION FACTOR: $Cv / 1.16 = kv$

**TABLE 5
STEAM CAPACITIES - LBS/HR; SATURATED STEAM**

Outlet Press. P2, psig	Inlet Press. P1, psig	Press. Drop psi	1/2" Body Size				3/4" Body Size				1" Body Size				1-1/4" & 1-1/2" Body Size				2" Body Size			
			DROOP				DROOP				DROOP				DROOP				DROOP			
			2.5%	5.0%	7.5%	10.0%	2.5%	5.0%	7.5%	10.0%	2.5%	5.0%	7.5%	10.0%	2.5%	5.0%	7.5%	10.0%	2.5%	5.0%	7.5%	10.0%
10	25	15	105	209	314	418	132	263	395	528	167	333	500	667	303	606	909	1212	591	1182	1773	2364
	50	40	181	361	541	721	228	455	683	910	288	575	863	1150	523	1046	1568	2091	1019	2039	3058	4078
	75	65	257	514	771	1028	324	648	972	1296	410	819	1229	1639	745	1490	2235	2980	1453	2905	4358	5810
	100	90	457	980	1111	1307	577	1236	1401	1648	729	1563	1771	2084	1326	2842	3221	3789	2586	5542	6280	7389
	125	115	713	1426	SONIC	SONIC	SONIC	898	1798	SONIC	SONIC	SONIC	SONIC	SONIC	2066	4132	4362	4591	4029	8057	8505	8953
	150	140	855	SONIC	SONIC	SONIC	1078	SONIC	SONIC	SONIC	SONIC	SONIC	SONIC	SONIC	2477	4944	5170	5386	4831	SONIC	SONIC	SONIC
	175	165	1004	SONIC	SONIC	SONIC	1265	SONIC	SONIC	SONIC	SONIC	SONIC	SONIC	SONIC	2908	SONIC	SONIC	SONIC	5671	SONIC	SONIC	SONIC
200	190	1133	SONIC	SONIC	SONIC	1429	SONIC	SONIC	SONIC	SONIC	SONIC	SONIC	SONIC	3285	SONIC	SONIC	SONIC	6406	SONIC	SONIC	SONIC	
15	50	35	179	358	537	716	225	451	677	902	285	570	856	1141	519	1037	1556	2074	1011	2022	3033	4045
	75	60	255	509	765	1019	321	642	964	1285	406	812	1219	1625	739	1477	2216	2954	1440	2880	4321	5761
	100	85	457	980	1111	1307	577	1236	1401	1648	729	1563	1771	2084	1326	2842	3221	3789	2586	5542	6280	7389
	125	110	713	1426	1505	1584	898	1798	1897	1997	1136	2273	2399	2525	2066	4132	4362	4591	4029	8057	8505	8953
	150	135	855	1706	SONIC	SONIC	SONIC	1078	2150	SONIC	SONIC	SONIC	SONIC	SONIC	2477	4944	5170	5386	4831	9641	10082	10502
	175	160	1004	SONIC	SONIC	SONIC	1265	SONIC	SONIC	SONIC	SONIC	SONIC	SONIC	SONIC	2908	5785	6002	6188	5671	SONIC	SONIC	SONIC
	200	185	1133	SONIC	SONIC	SONIC	1429	SONIC	SONIC	SONIC	SONIC	SONIC	SONIC	SONIC	3285	6535	SONIC	SONIC	6406	SONIC	SONIC	SONIC
20	50	30	175	350	525	700	221	441	662	883	279	558	837	1116	507	1015	1522	2030	989	1979	2968	3958
	75	55	248	496	743	990	321	625	936	1249	395	790	1184	1579	718	1436	2153	2871	1400	2799	4199	5598
	100	80	457	980	1111	1307	577	1236	1401	1648	729	1563	1771	2084	1326	2842	3221	3789	2586	5542	6280	7389
	125	105	713	1426	1505	1584	898	1798	1897	1997	1136	2273	2399	2525	2066	4132	4362	4591	4029	8057	8505	8953
	150	130	855	1706	1784	1858	1078	2150	2249	2343	1363	2719	2844	2962	2477	4944	5170	5386	4831	9641	10082	10502
	175	155	1004	1996	2071	2135	1265	2517	2611	2691	1600	3182	3301	3403	2908	5785	6002	6188	5671	11282	11704	12066
	200	180	1133	2254	2339	2411	1429	2843	2949	3040	1807	3594	3729	3844	3285	6535	6780	6990	6406	12744	13221	13630
25	50	25	169	337	505	674	213	425	637	849	269	537	805	1074	488	976	1464	1953	952	1904	2856	3808
	75	50	247	492	739	985	311	621	932	1243	393	785	1178	1571	714	1428	2142	2856	1392	2785	4177	5569
	100	75	449	961	1090	1285	566	1212	1374	1616	715	1532	1737	2043	1300	2786	3157	3715	2535	5433	6157	7243
	125	100	713	1426	1505	1584	898	1798	1897	1997	1136	2273	2399	2525	2066	4132	4362	4591	4029	8057	8505	8953
	150	125	855	1706	1784	1858	1078	2150	2249	2343	1363	2719	2844	2962	2477	4944	5170	5386	4831	9641	10082	10502
	175	150	1004	1996	SONIC	SONIC	SONIC	1265	2517	SONIC	SONIC	SONIC	SONIC	SONIC	2908	5785	6002	6188	5671	11282	11704	12066
	200	175	1133	SONIC	SONIC	SONIC	1429	SONIC	SONIC	SONIC	SONIC	SONIC	SONIC	SONIC	3285	6535	6780	6990	6406	SONIC	SONIC	SONIC
35	50	15	144	287	432	575	181	362	544	725	229	458	688	917	417	834	1250	167	813	1625	2438	3251
	75	40	238	477	716	955	301	602	902	1204	380	761	1141	1522	692	1383	2075	2767	1349	2698	4047	5395
	100	65	314	627	941	1255	395	791	1186	1582	500	1000	1500	2000	909	1818	2728	3637	1773	3546	5319	7092
	125	90	539	1156	1310	1541	680	1458	1652	1943	860	1843	2089	2457	1564	3351	3797	4468	3049	6534	7405	8712
	150	115	836	1672	1765	1858	1054	2109	2226	2343	1333	2666	2814	2962	2424	4847	5116	5386	4726	9452	9977	10502
	175	140	982	1960	2049	2135	1239	2471	2584	2691	1566	3124	3267	3403	2846	5680	5940	6188	5550	11076	11583	12066
	200	165	1133	2254	SONIC	SONIC	SONIC	1429	2843	SONIC	SONIC	SONIC	SONIC	SONIC	3285	6535	6780	6990	6406	12744	13221	13630
50	75	25	210	421	631	842	265	531	796	1061	335	671	1006	1342	610	1220	1830	2439	1189	2378	3567	4757
	100	50	302	604	906	1209	381	762	1143	1524	482	963	1445	1927	876	1751	2627	3503	1708	3415	5123	6831
	125	75	529	1135	1286	1513	668	1431	1621	1908	844	1809	2050	2412	1535	3289	3727	4385	2993	6413	7268	8551
	150	100	805	1611	1701	1790	1016	2031	2144	2256	1284	2568	2711	2853	2335	4669	4929	5188	4552	9105	9611	10117
	175	125	967	1928	2017	2101	1219	2431	2543	2649	1541	3074	3215	3349	2801	5590	5846	6089	5462	10900	11399	11874
	200	150	1133	2254	2339	2411	1429	2843	2949	3040	1807	3594	3729	3844	3285	6535	6780	6990	6406	12744	13221	13630
	250	200	1422	2874	2917	2962	1793	3623	3679	3735	2267	4581	4651	4722	4121	8328	8457	8586	8036	16240	16491	16742
75	100	25	245	491	736	982	309	619	929	1238	391	783	1174	1565	712	1423	2135	2846	1388	2775	4162	5550
	125	50	349	699	1048	1398	441	881	1322	1762	557	1114	1671	2228	1013	2026	3038	4051	1975	3950	5925	7900
	150	75	607	1299	1472	1733	765	1638	1856	2184	967	2071	2347	2762	1757	3766	4268	5021	3427	7343	8323	9791
	175	100	916	1832	1933	2035	1155	2309	2438	2566	1460	2920	3082	3244	2654	5308	5603	5898	5176	10351	10926	11501
	200	125	1066	2128	2226	2318	1345	2684	2806	2923	1700	3393	3548	3696	3091	6169	6452	6720	6028	12030	12581	13105
	250	175	1372	2730	2832	2920	1731	3442	3571	3682	2188	4352	4515	4655	3978	7913	8209	8463	7757	15431	16008	16503
	300	200	1422	2874	2917	2962	1793	3623	3679	3735	2267	4581	4651	4722	4121	8328	8457	8586	8036	16240	16491	16742
100	125	25	276	551	827	1103	348	695	1043	1391	440	879	1319	1759	799	1599	2398	3197	1559	3117	4676	6235
	150	50	391	782	1172	1563	493	985	1478	1971	623	1246	1869	2492	1133	2266	3398	4531	2209	4418	6627	8835
	175	75	676	1149	1642	1931	853	1827	2070	2435	1078	2310	2617	3079	1960	4199	4759	5599	3821	8188	9280	10918
	200	100	1016	2032	2145	2258	1280	2562	2704	2846	1619	3239	3419	3599	2944	5889	6216	6543	5741	11483	12121	12758
	250	150	1336	2658	2757	2843	1685	3352	3477	3												

TABLE 5 cont'd
STEAM CAPACITIES - LBS/HR; SATURATED STEAM

Outlet Press. P2, psig	Inlet Press. P1, psig	Press. Drop psi	3" Body Size				4" Body Size			
			DROOP				DROOP			
			2.5%	5.0%	7.5%	10.0%	2.5%	5.0%	7.5%	10.0%
10	25	15	LO DP	LO DP	LO DP	LO DP	LO DP	LO DP	LO DP	LO DP
	50	40	1725	3450	5176	6901	2300	4600	6901	9201
	75	65	2458	4916	7374	9833	3278	6555	9833	13110
	100	90	4376	9378	10628	12504	5835	12504	14171	16672
	125	115	6818	13636	14393	15151	9090	18181	19191	20201
	150	140	8176	16315	17062	17773	10901	21754	22749	23697
	175	165	9597	19092	SONIC	SONIC	12796	25456	26409	27225
	200	190	10841	SONIC	SONIC	SONIC	14454	28755	29831	30754
15	50	35	1711	3422	5134	6845	2282	4563	6845	9126
	75	60	2437	4875	7312	9749	3250	6499	9749	12999
	100	85	4376	9378	10628	12504	5835	12504	14171	16672
	125	110	6818	13636	14393	15151	9090	18181	19191	20201
	150	135	8176	16315	17062	17773	10901	21754	22749	23697
	175	160	9597	19092	19807	20419	12796	25456	26409	27225
	200	185	10841	21566	22373	23065	14454	28755	29831	30754
20	50	30	1674	3349	5023	6698	2233	4465	6698	8930
	75	55	2369	4737	7106	9474	3158	6316	9474	12632
	100	80	4376	9378	10628	12504	5835	12504	14171	16672
	125	105	6818	13636	14393	15151	9090	18181	19191	20201
	150	130	8176	16315	17062	17773	10901	21754	22749	23697
	175	155	9597	19092	19807	20419	12796	25456	26409	27225
	200	180	10841	21566	22373	23065	14454	28755	29831	30754
25	50	25	1611	3222	4833	6444	2148	4296	6444	8591
	75	50	2356	4712	7069	9425	3142	6283	9425	12567
	100	75	4290	9193	10419	12258	5720	12258	13892	16344
	125	100	6818	13636	14393	15151	9090	18181	19191	20201
	150	125	8176	16315	17062	17773	10901	21754	22749	23697
	175	150	9597	19092	19807	20419	12796	25456	26409	27225
	200	175	10841	21566	22373	23065	14454	28755	29831	30754
35	50	15	LO DP	LO DP	LO DP	LO DP	LO DP	LO DP	LO DP	LO DP
	75	40	2283	4565	6848	9131	3044	6087	9131	12174
	100	65	3000	6001	9001	12001	4000	8001	12001	16002
	125	90	5160	11057	12531	14743	6880	14743	16708	19657
	150	115	7998	15996	16884	17773	10664	21327	22512	23697
	175	140	9393	18745	19602	20419	12524	24993	26136	27225
	200	165	10841	21566	22373	23065	14454	28755	29831	30754
50	75	25	2012	4025	6037	8050	2683	5366	8050	10733
	100	50	2890	5780	8670	11560	3853	7706	11560	15413
	125	75	5065	10130	15195	20260	6753	13506	20260	27013
	150	100	7704	15408	23112	30816	10272	20544	30816	41088
	175	125	8243	16486	24729	33006	12325	24650	36975	49260
	200	150	10841	21566	22373	23065	14454	28755	29831	30754
	250	200	13600	27200	27908	28333	18133	36266	37210	37777
75	100	25	2348	4696	7044	9392	3131	6261	9392	12523
	125	50	3342	6684	10026	13368	4456	8912	13368	17825
	150	75	5799	11598	17397	23196	7733	15466	23196	30913
	175	100	8759	17517	26274	34951	11678	23356	35034	46711
	200	125	10202	20359	21290	22178	13602	27145	28387	29570
	250	175	13126	26113	27091	27929	17502	34818	36121	37238
100	125	25	2638	5276	7913	10551	3517	7034	10551	14068
	150	50	3738	7476	11214	14952	4984	9968	14952	19936
	175	75	6467	12934	19401	25868	8622	17244	25868	34456
	200	100	9416	18832	28248	37664	12955	25909	37664	50218
	250	150	12781	25562	26378	27194	17041	34081	35170	36258
	300	200	15599	31198	32010	32497	20798	41596	42679	43329
125	150	25	2895	5790	8684	11579	3860	7719	11579	15439
	175	50	4102	8204	12306	16408	5469	10939	16408	21878
	200	75	7076	14152	21228	28304	9435	18870	28304	37738
	250	125	12229	24405	25522	26585	16305	32610	34029	35447
150	300	175	15145	30290	31257	32224	20194	40388	41676	42965
	175	25	3134	6269	9403	12538	4179	8358	12538	16717
	200	50	4437	8875	13312	17749	5916	11833	17749	23666
	250	100	11409	22818	24085	25353	15212	30424	32114	33804
300	150	14852	29704	30651	31599	19802	39604	40869	42133	

MOUNTING POSITION "H"

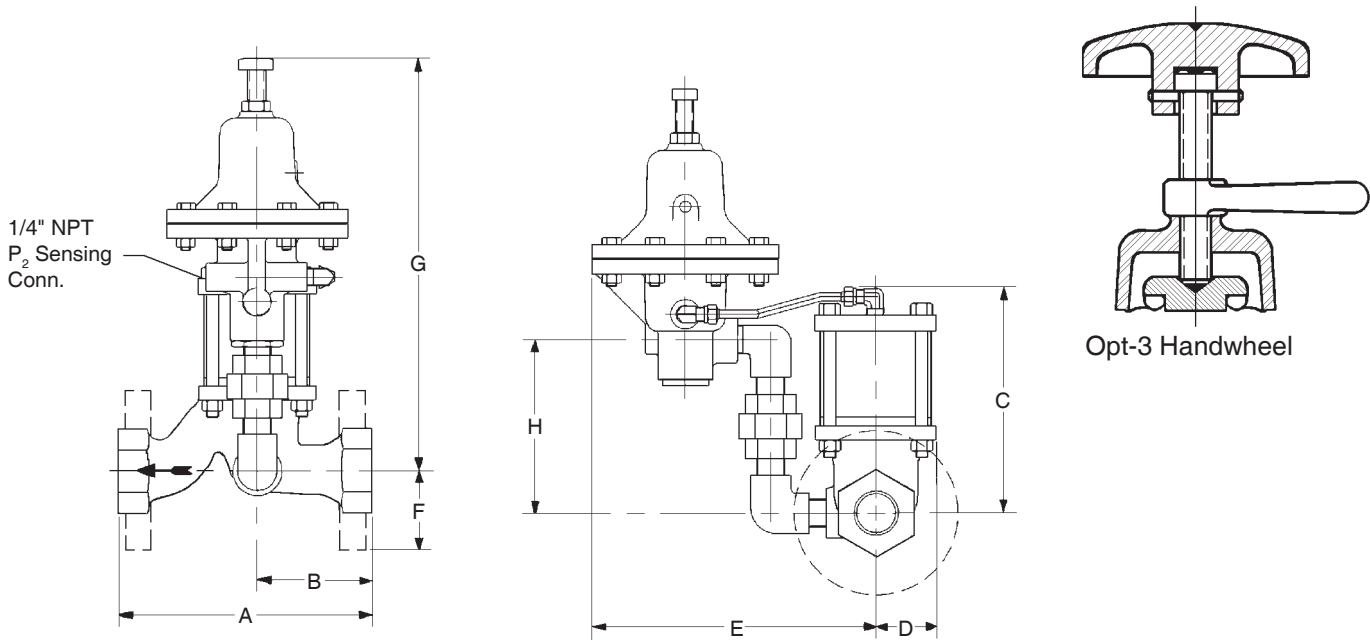

TABLE 6
DIMENSIONS & WEIGHT – POSITION "H"
(In Inches & Pounds)

Valve Size In.	"A"					"B"					"C"	"D"	"E"	"F"	"G" *	"H"	Approx. Weight Lbs.
	NPT	125# Flgd.	250# Flgd.	150# Flgd.	300# Flgd.	NPT	125# Flgd.	250# Flgd.	150# Flgd.	300# Flgd.							
1/2"	7.75	NA	NA	NA	NA	3.50	NA	NA	NA	NA	6.75	1.81	8.44	1.31	12.59	5.16	27
3/4"	7.75	NA	NA	NA	NA	3.50	NA	NA	NA	NA	6.75	1.81	8.44	1.31	12.59	5.16	27
1"	7.75	NA	NA	7.75	7.75	3.50	NA	NA	3.50	3.50	6.75	1.81	8.44	2.44	12.59	5.16	27
1-1/4"	9.25	NA	NA	NA	NA	4.12	NA	NA	NA	NA	7.19	1.81	8.94	1.88	12.59	5.16	31
1-1/2"	9.25	9.25	9.25	9.25	9.25	4.12	4.12	4.12	4.12	4.12	7.19	1.81	8.94	3.06	12.59	5.16	31
2"	10.50	10.50	10.50	10.50	10.50	4.62	4.62	4.62	4.62	4.62	9.62	3.06	9.94	3.25	13.09	5.66	62
3"	NA	12.50	12.50	12.50	12.50	NA	5.50	5.50	5.50	5.50	11.94	4.00	10.44	4.12	14.09	6.66	121
4"	NA	13.88	14.50	13.88	14.50	NA	6.94	7.25	6.94	7.25	12.69	5.00	11.44	5.00	14.09	6.66	222

* Add 1.69" for Opt-3 Handwheel.

(In Millimeters & Kilograms)

Valve Size (DN)	"A"					"B"					"C"	"D"	"E"	"F"	"G" *	"H"	Approx. Weight Kg.
	NPT	125# Flgd.	250# Flgd.	150# Flgd.	300# Flgd.	NPT	125# Flgd.	250# Flgd.	150# Flgd.	300# Flgd.							
(15)	197	NA	NA	NA	NA	89	NA	NA	NA	NA	171	46	214	33	320	131	12
(20)	197	NA	NA	NA	NA	89	NA	NA	NA	NA	171	46	214	33	320	131	12
(25)	197	NA	NA	197	197	89	NA	NA	89	89	171	46	214	62	320	131	12
(32)	235	NA	NA	NA	NA	105	NA	NA	NA	NA	183	46	227	48	320	131	14
(40)	235	235	235	235	235	105	105	105	105	105	183	46	227	78	320	131	14
(50)	267	267	267	267	267	117	117	117	117	117	244	78	252	83	332	144	28
(80)	NA	318	318	318	318	NA	140	140	140	140	303	102	265	105	358	169	55
(100)	NA	352	368	352	368	NA	176	184	176	184	322	127	290	127	358	169	101

* Add 43 mm for Opt-3 Handwheel.

MOUNTING POSITION "VU"

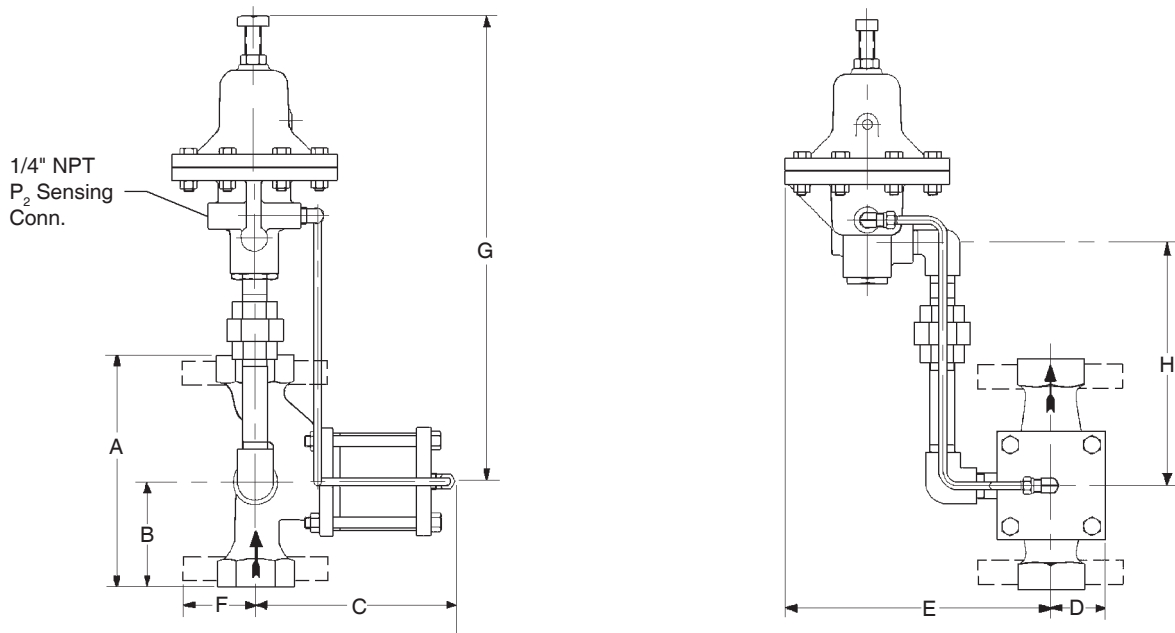

TABLE 7
DIMENSIONS & WEIGHT – POSITION "VU"
(In Inches & Pounds)

Valve Size In.	"A"					"B"					"C"	"D"	"E"	"F"	"G" *	"H"	Approx. Weight Lbs.
	NPT	125# Flgd.	250# Flgd.	150# Flgd.	300# Flgd.	NPT	125# Flgd.	250# Flgd.	150# Flgd.	300# Flgd.							
1/2"	7.75	NA	NA	NA	NA	3.50	NA	NA	NA	NA	6.75	1.81	8.94	1.31	15.59	8.16	27
3/4"	7.75	NA	NA	NA	NA	3.50	NA	NA	NA	NA	6.75	1.81	8.94	1.31	15.59	8.16	27
1"	7.75	NA	NA	7.75	7.75	3.50	NA	NA	3.50	3.50	6.75	1.81	8.94	2.44	15.59	8.16	27
1-1/4"	9.25	NA	NA	NA	NA	4.12	NA	NA	NA	NA	7.19	1.81	9.94	1.88	17.09	9.66	31
1-1/2"	9.25	9.25	9.25	9.25	9.25	4.12	4.12	4.12	4.12	4.12	7.19	1.81	9.94	3.06	17.09	9.66	31
2"	10.50	10.50	10.50	10.50	10.50	4.62	4.62	4.62	4.62	4.62	9.62	3.06	9.94	3.25	18.09	10.66	62
3"	NA	12.50	12.50	12.50	12.50	NA	5.50	5.50	5.50	5.50	11.94	4.00	10.94	4.12	19.59	12.16	121
4"	NA	13.88	14.50	13.88	14.50	NA	6.94	7.25	6.94	7.25	12.69	5.00	11.94	5.00	20.09	12.66	222

* Add 1.69" for Opt-3 Handwheel.

(In Millimeters & Kilograms)

Valve Size (DN)	"A"					"B"					"C"	"D"	"E"	"F"	"G" *	"H"	Approx. Weight Kg.
	NPT	125# Flgd.	250# Flgd.	150# Flgd.	300# Flgd.	NPT	125# Flgd.	250# Flgd.	150# Flgd.	300# Flgd.							
(15)	197	NA	NA	NA	NA	89	NA	NA	NA	NA	171	46	227	33	396	207	12
(20)	197	NA	NA	NA	NA	89	NA	NA	NA	NA	171	46	227	33	396	207	12
(25)	197	NA	NA	197	197	89	NA	NA	89	89	171	46	227	62	396	207	12
(32)	235	NA	NA	NA	NA	105	NA	NA	NA	NA	183	46	252	48	434	245	14
(40)	235	235	235	235	235	105	105	105	105	105	183	46	252	78	434	245	14
(50)	267	267	267	267	267	117	117	117	117	117	244	78	252	83	459	271	28
(80)	NA	318	318	318	318	NA	140	140	140	140	303	102	278	105	498	309	55
(100)	NA	352	368	352	368	NA	176	184	176	184	322	127	303	127	510	322	101

* Add 43 mm for Opt-3 Handwheel.

MOUNTING POSITION "VD"

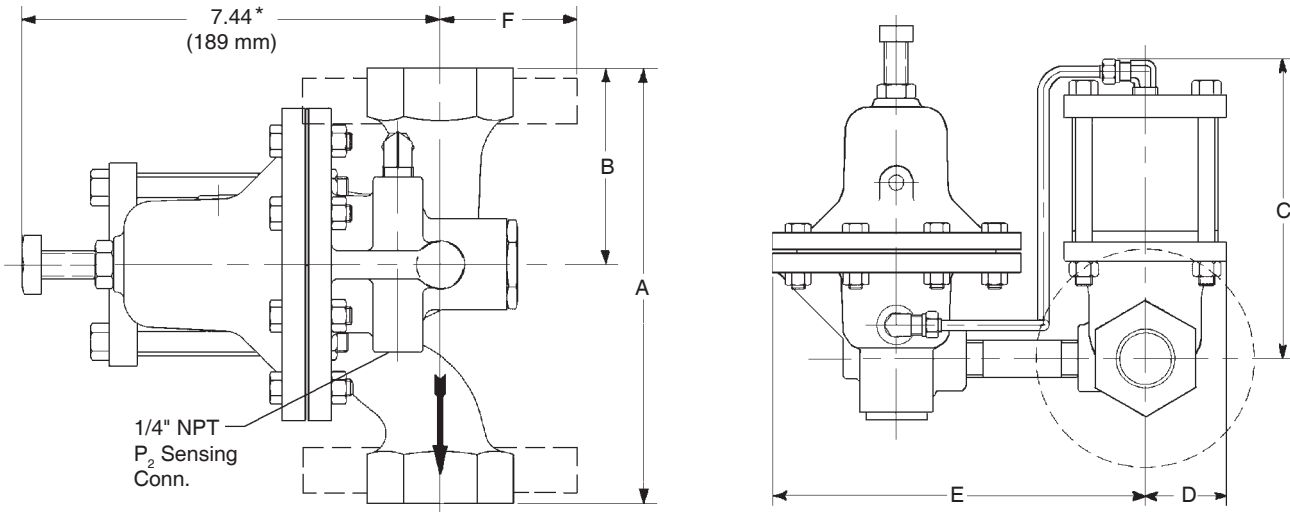

TOP VIEW

TABLE 8
DIMENSIONS & WEIGHT – POSITION "VD"
(In Inches & Pounds)

Valve Size In.	"A"					"B"					"C"	"D"	"E"	"F"	Approx. Weight Lbs.
	NPT	125# Flgd.	250# Flgd.	150# Flgd.	300# Flgd.	NPT	125# Flgd.	250# Flgd.	150# Flgd.	300# Flgd.					
1/2"	7.75	NA	NA	NA	NA	3.50	NA	NA	NA	NA	6.75	1.81	8.38	1.31	25
3/4"	7.75	NA	NA	NA	NA	3.50	NA	NA	NA	NA	6.75	1.81	8.38	1.31	25
1"	7.75	NA	NA	7.75	7.75	3.50	NA	NA	3.50	3.50	6.75	1.81	8.38	2.44	25
1-1/4"	9.25	NA	NA	NA	NA	4.12	NA	NA	NA	NA	7.19	1.81	8.88	1.88	29
1-1/2"	9.25	9.25	9.25	9.25	9.25	4.12	4.12	4.12	4.12	4.12	7.19	1.81	8.88	3.06	29
2"	10.50	10.50	10.50	10.50	10.50	4.62	4.62	4.62	4.62	4.62	9.62	3.06	9.38	3.25	60
3"	NA	12.50	12.50	12.50	12.50	NA	5.50	5.50	5.50	5.50	11.94	4.00	10.38	4.12	119
4"	NA	13.88	14.50	13.88	14.50	NA	6.94	7.25	6.94	7.25	12.69	5.00	11.38	5.00	220

* Add 1.69" for Opt-3 Handwheel.

(In Millimeters & Kilograms)

Valve Size (DN)	"A"					"B"					"C"	"D"	"E"	"F"	Approx. Weight Kg.
	NPT	125# Flgd.	250# Flgd.	150# Flgd.	300# Flgd.	NPT	125# Flgd.	250# Flgd.	150# Flgd.	300# Flgd.					
(15)	197	NA	NA	NA	NA	89	NA	NA	NA	NA	171	46	213	33	11
(20)	197	NA	NA	NA	NA	89	NA	NA	NA	NA	171	46	213	33	11
(25)	197	NA	NA	197	197	89	NA	NA	89	89	171	46	213	62	11
(32)	235	NA	NA	NA	NA	105	NA	NA	NA	NA	183	46	225	48	13
(40)	235	235	235	235	235	105	105	105	105	105	183	46	225	78	13
(50)	267	267	267	267	267	117	117	117	117	117	244	78	238	83	27
(80)	NA	318	318	318	318	NA	140	140	140	140	303	102	264	105	54
(100)	NA	352	368	352	368	NA	176	184	176	184	322	127	289	127	100

* Add 43 mm for Opt-3 Handwheel.

The contents of this publication are presented for informational purposes only, and while every effort has been made to ensure their accuracy, they are not to be construed as warranties or guarantees, express or implied, regarding the products or services described herein or their use or applicability. We reserve the right to modify or improve the designs or specifications of such product at any time without notice. Cashco, Inc. does not assume responsibility for the selection, use or maintenance of any product. Responsibility for proper selection, use and maintenance of any Cashco, Inc. product remains solely with the purchaser.

MODEL POSR-2 PRODUCT CODER 02/07/20

An "X" in POS 12 followed by a 5-digit control number overrides remaining selections.

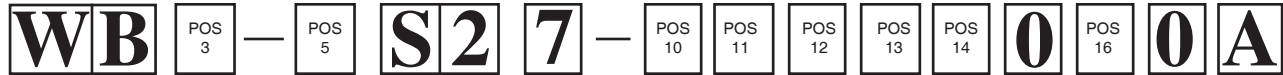

POSITION 3 - SIZE		
Size		CODE
In	(DN)	
1/2"	(15)	A
3/4"	(20)	B
1"	(25)	1
1-1/4"	(32)	F
1-1/2"	(40)	G
2"	(50)	2
3"	(80)	3*
4"	(100)	4*

*Flanged Only

POSITION 5 - MATERIALS & MOUNTING POSITION				
Main Valve Body/Cyl/Bonnet	Pilot Valve Body/Sp. Ch.	Mounting Position		
		H CODE	VD CODE	VU CODE
DI/SST/DI	DI/IR	A	6	J
CS/SST/DI	DI/IR	B	7	K
CS/SST/DI	DI/CS	C	8	L

POSITION 10 - END CONNECTIONS	
Description	CODE
NPT - Screwed	1
-30 Opt. - 125 LB Flgs. DI Only	3
-30 Opt.-150 LB Flgs. CS Only	6
-30 Opt.- 250 LB Flgs. DI Only	5
-30 Opt.- 300 LB Flgs. CS Only	7

POSITION 11 - RANGE SPRINGS				
Steel Range Spring		STD.*	5 PSID	
psig	(Barg)	CODE	CODE	
5-15	(.34-1.0)	1	A	
10-40	(.69-2.8)	2	B	
30-80	(2.1-5.5)	3	C	
70-150	(4.8-10.3)	4	D	

*Std.: 15 psid for 1" thru 2" sizes and 20 psid for 3" & 4" sizes.

POSITION 12 - TRIM OPTIONS		
Description	Option	CODE
No Option	---	0
For Special Construction Contact Cashco for Special Product Code.	SPQ	X

POSITION 13 - FEATURE OPTIONS		
Description	Option	CODE
No Option	-	0
Handwheel & Locking Lever.	-3	3

POSITION 14 - SPRING CHAMBER OPTIONS		
Description	Option	CODE
No Option	---	0
1/8" (DN6) NPT Vent Tap	-25	D
SST Rain-proof Bug Vent (includes Opt-25).	-25S	H

POSITION 16 - CERTIFICATE OPTIONS		
Description	Option	CODE
No Option	-	0
Special Cleaning: Per Cashco Spec #S-1542.	-56	N

*** For information on ATEX see pages 19 & 20 on the IOM.**

Алматы (7273)495-231
 Ангарск (3955)60-70-56
 Архангельск (8182)63-90-72
 Астрахань (8512)99-46-04
 Барнаул (3852)73-04-60
 Белгород (4722)40-23-64
 Благовещенск (4162)22-76-07
 Брянск (4832)59-03-52
 Владивосток (423)249-28-31
 Владикавказ (8672)28-90-48
 Владимир (4922)49-43-18
 Волгоград (844)278-03-48
 Вологда (8172)26-41-59
 Воронеж (473)204-51-73
 Екатеринбург (343)384-55-89

Иваново (4932)77-34-06
 Ижевск (3412)26-03-58
 Иркутск (395)279-98-46
 Казань (843)206-01-48
 Калининград (4012)72-03-81
 Калуга (4842)92-23-67
 Кемерово (3842)65-04-62
 Киров (8332)68-02-04
 Коломна (4966)23-41-49
 Кострома (4942)77-07-48
 Краснодар (861)203-40-90
 Красноярск (391)204-63-61
 Курск (4712)77-13-04
 Курган (3522)50-90-47
 Липецк (4742)52-20-81

Магнитогорск (3519)55-03-13
 Москва (495)268-04-70
 Мурманск (8152)59-64-93
 Набережные Челны (8552)20-53-41
 Нижний Новгород (831)429-08-12
 Новокузнецк (3843)20-46-81
 Ноябрьск (3496)41-32-12
 Новосибирск (383)227-86-73
 Омск (3812)21-46-40
 Орел (4862)44-53-42
 Оренбург (3532)37-68-04
 Пенза (8412)22-31-16
 Петрозаводск (8142)55-98-37
 Псков (8112)59-10-37
 Пермь (342)205-81-47

Ростов-на-Дону (863)308-18-15
 Рязань (4912)46-61-64
 Самара (846)206-03-16
 Санкт-Петербург (812)309-46-40
 Саратов (845)249-38-78
 Севастополь (8692)22-31-93
 Саранск (8342)22-96-24
 Симферополь (3652)67-13-56
 Смоленск (4812)29-41-54
 Сочи (862)225-72-31
 Ставрополь (8652)20-65-13
 Сургут (3462)77-98-35
 Сыктывкар (8212)25-95-17
 Тамбов (4752)50-40-97
 Тверь (4822)63-31-35

Тольятти (8482)63-91-07
 Томск (3822)98-41-53
 Тула (4872)33-79-87
 Тюмень (3452)66-21-18
 Ульяновск (8422)24-23-59
 Улан-Удэ (3012)59-97-51
 Уфа (347)229-48-12
 Хабаровск (4212)92-98-04
 Чебоксары (8352)28-53-07
 Челябинск (351)202-03-61
 Череповец (8202)49-02-64
 Чита (3022)38-34-83
 Якутск (4112)23-90-97
 Ярославль (4852)69-52-93

Россия +7(495)268-04-70

Казахстан +7(7172)727-132

Киргизия +996(312)96-26-47

<https://cashco.nt-rt.ru/> || coc@nt-rt.ru