

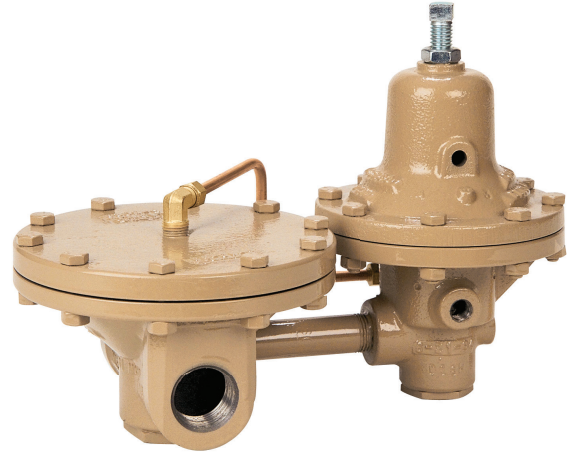

ISO Registered Company

MODEL POSR-1

PRESSURE REDUCING REGULATOR PILOT OPERATED



MODEL POSR-1

OVERVIEW

The Model POSR-1 is a pilot operated regulator primarily for use with steam. The external pilot valve is supplied from a main valve body tapped connection. Sizes are 1/2", 3/4" and 1" (DN15, 20 and 25). Handles pressure drops up to 200 psi (13.8 Bar) with adjustable outlet pressures between 5 and 150 psig (.34 and 10.3 Barg). Also available without the pilot as a pressure loaded regulator.

FEATURES

- Hardened Trim:** 416 SST hardened pilot and main valve trim for long life.
- Bellows Seal:** The pilot uses a bellows as a frictionless seal for the pilot valve plug. It was incorporated to ensure that the pilot maintains its sensitivity and smooth operation in older steam systems that are chemically treated and systems that are used intermittently.
- High Sensitivity:** Four pilot range springs provide high sensitivity and contribute to the valve's excellent stability.
- Two Body Materials:** Ductile iron or cast steel.
- Easy to Install:** A 1/4" (DN8) NPT sensing line and the valve body are the only connections required.



LINE SIZES AVAILABLE

1/2" (DN15), 3/4" (DN20), 1" (DN25)



END CONNECTIONS

FNPT



COMMON APPLICATIONS

STEAM HEATING



DESIGN PRESSURE

INLET: UP TO 300 psig (20.7 Barg)

OUTLET: 5-150 psig (0.34-10.3 Barg)

Алматы (7273)495-231
 Ангарск (3955)60-70-56
 Архангельск (8182)63-90-72
 Астрахань (8512)99-46-04
 Барнаул (3852)73-04-60
 Белгород (4722)40-23-64
 Благовещенск (4162)22-76-07
 Брянск (4832)59-03-52
 Владивосток (423)249-28-31
 Владикавказ (8672)28-90-48
 Владимир (4922)49-43-18
 Волгоград (844)278-03-48
 Вологда (8172)26-41-59
 Воронеж (473)204-51-73
 Екатеринбург (343)384-55-89

Иваново (4932)77-34-06
 Ижевск (3412)26-03-58
 Иркутск (395)279-98-46
 Казань (843)206-01-48
 Калининград (4012)72-03-81
 Калуга (4842)92-23-67
 Кемерово (3842)65-04-62
 Киров (8332)68-02-04
 Коломна (4966)23-41-49
 Кострома (4942)77-07-48
 Краснодар (861)203-40-90
 Красноярск (391)204-63-61
 Курск (4712)77-13-04
 Курган (3522)50-90-47
 Липецк (4742)52-20-81

Магнитогорск (3519)55-03-13
 Москва (495)268-04-70
 Мурманск (8152)59-64-93
 Набережные Челны (8552)20-53-41
 Нижний Новгород (831)429-08-12
 Новокузнецк (3843)20-46-81
 Ноябрьск (3496)41-32-12
 Новосибирск (383)227-86-73
 Омск (3812)21-46-40
 Орел (4862)44-53-42
 Оренбург (3532)37-68-04
 Пенза (8412)22-31-16
 Пермь (342)205-81-47
 Петрозаводск (8142)55-98-37
 Псков (8112)59-10-37
 Пермь (342)205-81-47

Ростов-на-Дону (863)308-18-15
 Рязань (4912)46-61-64
 Самара (846)206-03-16
 Санкт-Петербург (812)309-46-40
 Саратов (845)249-38-78
 Севастополь (8692)22-31-93
 Саранск (8342)22-96-24
 Сочи (862)225-72-31
 Симферополь (3652)67-13-56
 Смоленск (4812)29-41-54
 Сочи (862)225-72-31
 Ставрополь (8652)20-65-13
 Сургут (3462)77-98-35
 Сыктывкар (8212)25-95-17
 Тамбов (4752)50-40-97
 Тверь (4822)63-31-35

Тольятти (8482)63-91-07
 Томск (3822)98-41-53
 Тула (4872)33-79-87
 Тюмень (3452)66-21-18
 Ульяновск (8422)24-23-59
 Улан-Уда (3012)59-97-51
 Уфа (347)229-48-12
 Хабаровск (4212)92-98-04
 Чебоксары (8352)28-53-07
 Челябинск (351)202-03-61
 Череповец (8202)49-02-64
 Чита (3022)38-34-83
 Якутск (4112)23-90-97
 Ярославль (4852)69-52-93

Россия +7(495)268-04-70

Казахстан +7(7172)727-132

Киргизия +996(312)96-26-47

STANDARD/GENERAL SPECIFICATIONS

Body Sizes:	1/2", 3/4" and 1" (DN15, 20 and 25).
End Connections:	NPT female.
Unit Materials:	See Table 1 for material specifications. <u>Main Valve</u> – DI or CS. <u>Pilot Valve</u> – DI body, CI or CS spring chamber.
	CI = Cast Iron CS = Carbon Steel DI = Ductile Iron
Maximum Inlet Pressure:	300 psig (20.7 Barg), all materials.
Maximum Inlet Temperature:	450° F (232° C).
Outlet Pressure Range:	5-150 psig (.34-10.3 Barg) in four range springs. See Table 2.
Pressure Drop Limits:	<u>Maximum</u> – 200 psid (13.8 Bard). <u>Minimum</u> – Standard – 15 psid (1.0 Bard). Low – 5 psid (0.3 Bard).
Maximum Emergency Outlet Pressure:	Function of spring range –5-15 psig (.34-1.0 Barg), 100 psig (6.9 Barg). <u>All other spring ranges</u> – 200 psig (13.8 Bard).
Capacity:	See Table 5. Up to 5.5 Cv (4.7 kv), with Droop @ 10%.
Painting:	<u>Standard:</u> All non-corrosion resistant portions to be painted with corrosion resistant epoxy paint per Cashco Spec #S-1606.

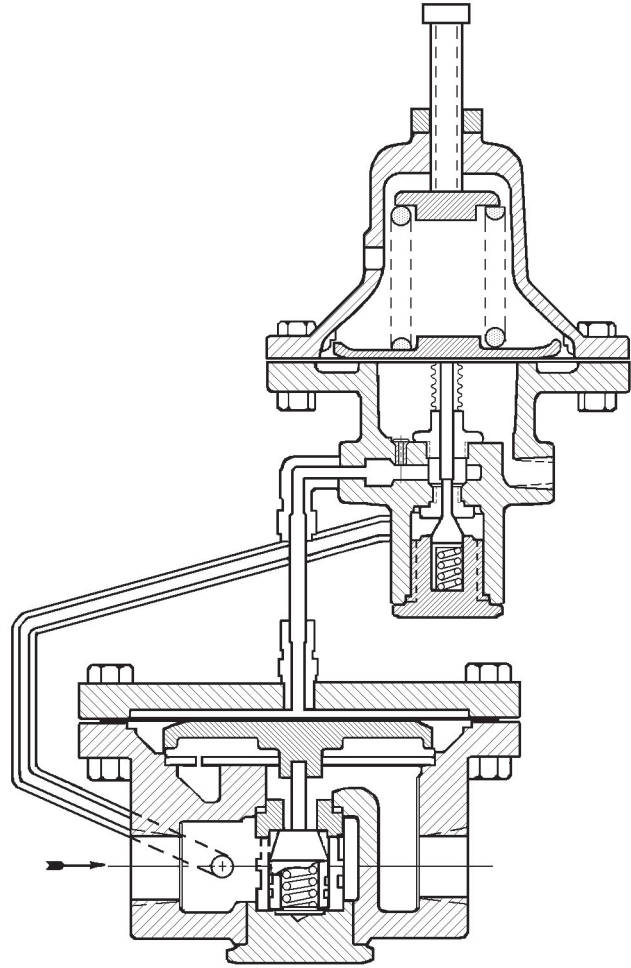

Figure 1: POSR-1

MAIN VALVE MATERIAL SPECIFICATIONS

Body/Body Cap:	DI/SST – ASTM A395 / ASTM A479 Alloy S31600/03 CS/SST – ASTM A216, Gr. WCB./ ASTM A479 Alloy S31600/03	Interconnection	
Loading Chamber:	DI – ASTM A395. CS – ASTM A516 Gr 70	Pipe & Fittings:	<u>Pipe:</u> ASTM A53, Gr. B, or ASTM A106, Gr. B carbon steel. <u>Fittings:</u> 300# malleable iron, per ANSI B16.3.
Diaphragm Bolting:	Plated steel.	Tubing & Fittings:	Annealed copper tube and brass "bite-type" compression fittings.
Diaphragm Gasket:	Graphite NBR.	Internal Trim:	See Table 4. Trim Designation No. "S2".

PILOT VALVE MATERIAL SPECIFICATIONS

Body:	DI – ASTM A395.	Pressure Plate:	Cast iron.
Spring Chamber:	CI – ASTM A126, Class B. CS – ASTM A216, Gr. WCB.	Spring Button:	Cast iron.
Body Cap:	SST – ASTM A479 Alloy S31600/03	Range Springs:	Epoxy coated steel.
Diaphragm Bolting:	Plated steel.	Adjusting Screw & Lock Nut:	Plated steel.
Diaphragm Gasket:	Graphite NBR.	Internal Trim:	See Table 4. Trim Designation No. "S2".

OPTION SPECIFICATIONS

- Option -3:** HAND WHEEL & LOCKING LEVER.
Utilize when pressure setting changes are frequent.
- Option-20:** PRESSURE LOADED REDUCER.
Main valve body only; i.e. no pilot valve. Allows for remote control or programmed control in batching operations. May even be loaded with air from an I/P transducer. See Table 6 for flow capacity. **NOTE:** There is an inlet (P_1) pressure influence on the outlet pressure if the P_1 pressure varies. See Figure 2.

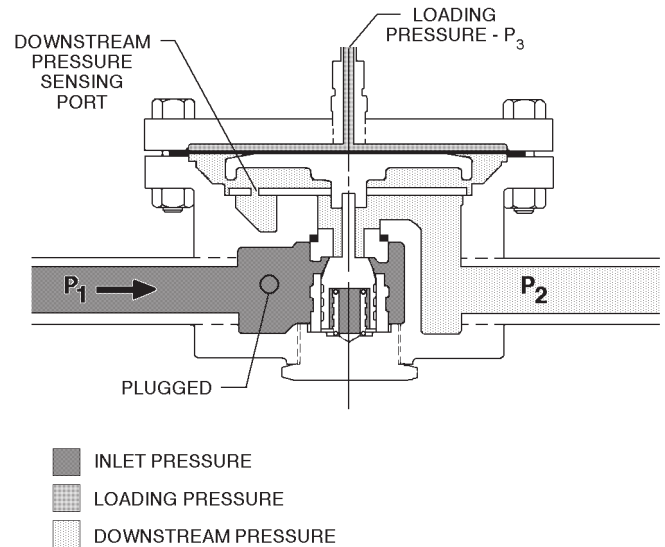

Figure 2: POSR-1-20

Outlet Pressure - P_2		Loading Pressure - P_3 , psig (Barg)			
psig	(Barg)	@ P_1 Minimum		@ P_1 Maximum	
5	(0.34)	15	(1.03)	25	(1.7)
50	(3.45)	60	(4.1)	70	(4.8)
100	(6.90)	110	(7.6)	120	(8.3)
130	(8.97)	145	(10.0)	150	(10.3)
135	(9.31)	150	(10.3)	—	—

- Option-56:** SPECIAL CLEANING. Cleaning per Cashco Spec #S-1542. Higher degree of cleaning than the standard commercial cleaning.

PRINCIPLES OF OPERATION

The POSR-1 pilot obtains its operating medium from the main valve body inlet pressure P_1 of the regulator. Downstream pressure P_2 registers on the underside of the main valve's diaphragm and the pilot valve's diaphragm.

The loading pressure on the main valve's diaphragm is higher than the downstream P_2 pressure by the sum of the pressures required to overcome the main valve's plug unbalance force and the plug's spring force.

The pilot has a downstream bleed orifice that bleeds part of the loading medium downstream. In operation, the pilot valve's plug can flow more medium than is bled downstream. This increases the loading pressure on the main valve's diaphragm which increases the opening of the valve's plug. Partially closing the pilot valve's plug will reduce its flow to less than the amount bleeding downstream, and allows the loading pressure on the main valve's diaphragm to decay, causing the diaphragm to rise and

TECHNICAL SPECIFICATIONS

TABLE 1 DESIGN PRESSURE-TEMPERATURE MATERIAL SPECIFICATIONS

Body - Loading Chamber (Body Cap)		Body - Spring Chamber		Main Valve End Conns.	Inlet				* Operating Pressure	Outlet			
										** Emergency Overpressure			
Main Valve		Pilot Valve			Spring Range								
Descrip. (Abbr.)	ASTM No.	Descrip. (Abbr.)	ASTM No.		Pressure		Temp		psig (Barg)	10-40 psig 30-80 psig 70-150 psig		5-15 psig	
				psig	(Barg)	°F	(°C)	psig		(Barg)	psig	(Barg)	
DI-DI (SST)	A395 (A479 Alloy S31600/03)	DI-CI	A395-A126, Cl. B	NPT	300	20.7	450	(232)	1.10 x UVRS up to 150 psig (up to 10.3 Barg)	150	(10.3)	100	(6.9)
CS-DI (SST)	A216 WCB-A395 (A479 Alloy S31600/03)	DI-CI	A395-A126, Cl. B	NPT	300	20.7	450	(232)	1.10 x UVRS up to 150 psig (up to 10.3 Barg)	150	(10.3)	100	(6.9)
CS-CS (SST)	A216 WCB-A516 GRADE 70 (A479 Alloy S31600/03)	DI-CS	A395-A216, Gr. WCB	NPT	300	20.7	450	(232)		200	(13.8)	100	(6.9)

* Limit is the lower pressure value of 125/150 psig (8.6/10.3 Barg), or the factor x UVRS (UVRS - "Upper Value of Range Spring"). Example: Steel body – for a 30-80 psig (2.1-5.5 Barg) standard range spring, the 1.10 x UVRS value = 1.10 x 80 = 88 psig; 88 < 150, therefore pressure limit = 88 psig (1.10 x 5.5 = 6.1 Barg; 6.1 < 10.3, therefore pressure limit = 6.1 Barg).

** Emergency Overpressure: Safety relief valve $P_{setpoint} + P_{accumulation}$ must not exceed this pressure level.

NOTE: All outlet temperature levels are thermodynamically determined by the maximum inlet pressure/temperature conditions.

METRIC CONVERSION FACTOR: psig / 14.5 = Barg.

TABLE 2 RANGE SPRINGS

Outlet Range		Emergency Overpressure	
psig	(Barg)	psig	(Barg)
5-15	(.34-1.03)	100	(6.9)
10-40	(.69-2.8)	200	(13.8)
30-80	(2.1-5.5)		
70-150	(4.8-10.3)		

TABLE 3 MAXIMUM Cv WITH PLUG WIDE OPEN (Use for Safety Relief Valve Sizing)

Body Size		Max Cv
in	(DN)	
1/2"	(15)	3.4
3/4"	(20)	3.8
1"	(25)	5.8

TABLE 4 TRIM MATERIALS - TRIM DESIGNATION NO.

Trim Designation No.	Valve Portion	Part Description	Trim Material
S2	Main	Plug	416 SST – hardened *
		Cylinder (seat)	416 SST – hardened *
		Plug Spring	302 SST
		Diaphragm(s)	302 SST
		Cylinder Gasket	Grafoil
		Pusher Plate	Cast Iron
		Shield & Screw	18-8 SST
	Pilot	Plug	416 SST – hardened *
		Seat	416 SST – hardened *
		Plug Spring	302 SST
		Stem Extension	416 SST
		Bellows Assembly	Brass/Bronze
		Screen	316 SST
		Diaphragm(s)	302 SST
Seat Gasket	Annealed Copper		

* Hardness – Rc ≈ 35 to 39.
NOTE: Cashco, Inc. does not recommend metal seated trim on any flow service that will dead end down stream of the pressure reducing regulator.

**TABLE 5
STEAM CAPACITIES IN LBS/HR; SATURATED STEAM**

OUTLET PRESSURE	INLET PRESSURE	PRESSURE DROP	#/HR @ 1/2" (DN15) BODY SIZE				#/HR @ 3/4" (DN20) BODY SIZE				#/HR @ 1" (DN25) BODY SIZE			
			DROOP				DROOP				DROOP			
P2, psig	P1, psig	psi	2.5%	5.0%	7.5%	10.0%	2.5%	5.0%	7.5%	10.0%	2.5%	5.0%	7.5%	10.0%
10	25	15	47	93	140	187	54	109	163	218	86	171	256	342
	50	40	82	165	247	329	96	192	288	384	151	302	453	604
	75	65	115	231	346	461	135	269	404	538	211	423	634	846
	100	90	210	450	510	600	245	525	595	700	385	825	935	1100
	125	115	327	654	691	727	382	763	806	848	600	1199	1266	1333
	150	140	392	783	819	853	458	913	955	995	719	1435	1501	1563
15	175	165	461	916	950	980	537	1069	1109	1143	844	1679	1742	1796
	200	190	520	1035	1074	1107	607	1207	1252	1291	954	1897	1968	2029
	50	35	81	162	243	324	95	189	283	378	148	297	445	594
	75	60	114	227	341	454	133	265	398	530	208	416	625	833
	100	85	208	445	504	593	242	519	588	692	381	816	924	1088
	125	110	327	654	691	727	382	763	806	848	600	1199	1266	1333
20	150	135	392	783	819	853	458	913	955	995	719	1435	1501	1563
	175	160	461	916	950	980	537	1069	1109	1143	844	1679	1742	1796
	200	185	520	1035	1074	1107	607	1207	1252	1291	954	1897	1968	2029
	50	30	79	157	236	315	92	184	275	367	144	288	433	577
	75	55	113	226	339	452	132	264	395	527	207	414	621	828
	100	80	202	434	492	578	236	506	573	675	371	795	901	1060
25	125	105	326	651	688	724	380	760	802	844	597	1194	1261	1327
	150	130	392	783	819	853	458	913	955	995	719	1435	1501	1563
	175	155	461	916	950	980	537	1069	1109	1143	844	1679	1742	1796
	200	180	520	1035	1074	1107	607	1207	1252	1291	954	1897	1968	2029
	50	25	75	150	225	301	88	175	263	351	138	276	413	551
	75	50	112	223	335	447	130	261	391	521	205	409	614	819
35	100	75	202	433	491	577	236	505	572	673	370	794	899	1058
	125	100	318	636	671	706	371	742	783	824	583	1166	1230	1295
	150	125	392	783	819	853	458	913	955	995	719	1435	1501	1563
	175	150	461	916	950	980	537	1069	1109	1143	844	1679	1742	1796
	200	175	520	1035	1074	1107	607	1207	1252	1291	954	1897	1968	2029
	50	15	63	127	190	254	74	148	222	296	116	233	349	465
50	75	40	107	214	321	428	125	250	375	499	196	392	589	785
	100	65	142	285	427	569	166	332	498	664	261	522	783	1044
	125	90	245	524	594	699	285	611	693	815	448	961	1089	1281
	150	115	370	740	781	822	432	863	911	959	678	1356	1432	1507
	175	140	445	887	928	967	519	1035	1083	1128	815	1627	1701	1772
	200	165	520	1035	1074	1107	607	1207	1252	1291	954	1897	1968	2029
75	75	25	93	186	279	372	109	217	326	434	171	341	512	683
	100	50	135	271	406	542	158	316	474	632	248	496	745	993
	125	75	240	513	582	684	279	599	679	798	439	941	1066	1255
	150	100	367	734	775	816	428	857	904	952	673	1346	1421	1495
	175	125	434	866	905	943	506	1010	1056	1100	795	1587	1659	1728
	200	150	501	997	1035	1067	585	1164	1207	1244	919	1828	1897	1956
100	250	200	651	1316	1337	1357	760	1536	1560	1583	1194	2413	2451	2488
	100	25	108	216	324	433	126	252	379	505	198	397	595	793
	125	50	156	311	467	622	182	363	544	726	285	570	855	1141
	150	75	272	583	661	778	318	680	771	907	499	1069	1212	1426
	175	100	414	828	874	920	483	966	1019	1073	759	1517	1602	1686
	200	125	485	967	1012	1054	566	1129	1180	1229	889	1774	1855	1932
125	250	175	615	1223	1269	1308	717	1427	1481	1526	1127	2243	2327	2399
	125	25	121	242	364	485	141	283	424	566	222	444	667	889
	150	50	173	347	520	693	202	404	606	808	318	635	953	1270
	175	75	302	647	733	862	352	755	855	1006	553	1186	1344	1581
	200	100	456	913	963	1014	532	1065	1124	1183	837	1673	1766	1859
	250	150	606	1206	1251	1290	707	1407	1460	1505	1112	2211	2294	2365
150	300	200	744	1503	1526	1549	868	1753	1780	1807	1363	2755	2798	2840
	150	25	133	266	398	531	155	310	465	620	243	487	730	974
	175	50	190	379	569	758	221	442	663	885	348	695	1043	1390
	200	75	329	705	799	940	384	823	932	1097	603	1293	1465	1724
	250	125	575	1147	1199	1249	671	1338	1399	1458	1054	2103	2199	2291
150	300	175	718	1428	1481	1527	837	1666	1728	1781	1316	2617	2715	2799
	175	25	144	287	431	574	168	335	503	670	263	526	790	1053
	200	50	205	409	614	818	239	477	716	955	375	750	1125	1500
	250	100	532	1064	1123	1182	620	1241	1310	1379	975	1950	2058	2167
	300	150	698	1389	1441	1486	815	1621	1681	1733	1280	2547	2642	2724

METRIC CONVERSION FACTORS: psig / 14.5 = Barg; LBS/Hr x 0.4536 = kg/Hr.

**TABLE 6
PRESSURE LOADED POSR-1-20 MAIN VALVE
STEAM CAPACITIES IN LBS/HR
SATURATED STEAM**

Flowing Outlet Pressure * psig	Inlet Pressure psig	Body 1/2" (DN15)	Body 3/4" (DN20)	Body 1" (DN25)
5	20	140	150	220
	30	180	220	250
	50	210	260	270
	75	210	290	330
	100	210	300	360
	150	210	300	360
10	200	210	300	360
	25	180	190	270
	30	200	200	310
	50	240	260	310
	75	240	300	360
	100	240	300	400
15	150	240	300	440
	200	240	300	460
	30	190	200	260
	50	240	280	340
	75	240	330	420
	100	250	360	440
25	150	270	360	500
	200	320	360	500
	40	230	240	340
	50	260	300	390
	75	270	360	450
	100	310	400	520
35	150	340	400	580
	200	340	400	600
	225	340	400	630
	50	260	270	420
	75	340	370	490
	100	340	450	610
50	150	380	460	680
	200	400	460	680
	225	400	460	680
	65	300	310	510
	75	370	390	610
	100	400	510	720
75	150	450	600	840
	200	500	640	920
	250	570	660	920
	100	400	460	780
	150	730	860	1100
100	200	730	910	1100
	250	730	920	1100
	125	500	530	870
	150	720	740	1300
	200	910	1000	1400
100	250	950	1200	1400
	300	980	1200	1400

NOTE: Many of the above capacities meet or exceed the velocities recommended for piping. Use reducers and larger pipe to reduce the velocities to acceptable limits.
* Pressure increases 20% when flow is reduced to 2% of published figures, except the 5 to 15 psig range has an increase of 4 psig.
METRIC CONVERSION FACTORS: psig / 14.5 = Barg; LBS/Hr x 0.4536 = kg/Hr.

DIMENSIONS & WEIGHT

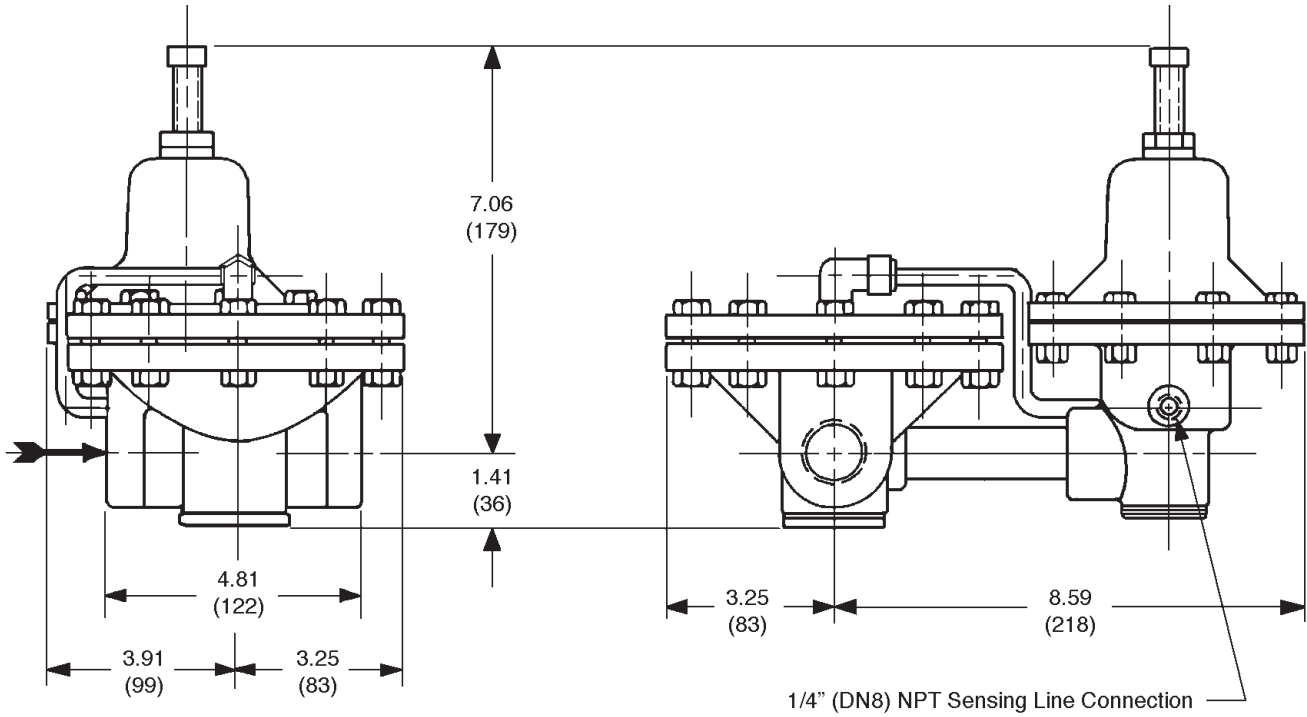

POSR-1, Sizes 1/2", 3/4" and 1" (DN15, 20 & 25)

WEIGHT FOR POSR-1 IS APPROX. 27 LBS. (12 KG)

All dimensions in inches with mm in ()

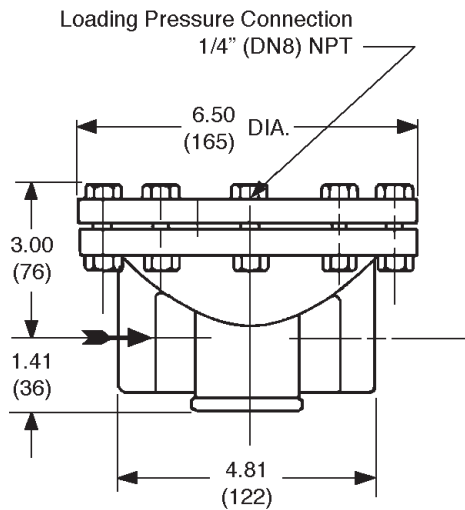

POSR-1-20
Pressure Loaded Main Valve

WEIGHT FOR POSR-1-20 IS APPROX. 18 LBS (8.2 KG)

MODEL POSR-1 PRODUCT CODER 02/07/20

An "X" in POS 12 followed by a 5-digit control number overrides remaining selections.



POSITION 3 - SIZE		
Size		CODE
In	(DN)	
1/2"	(15)	4
3/4"	(20)	5
1"	(25)	6

POSITION 5 - MATERIALS		
Main Valve Body / Loading Chamber (Body Cap)	Pilot Body/ Spring Chamber	CODE
DI/DI (SST)	DI/IR	1
CS/DI (SST)	DI/IR	2
CS/CS (SST)	DI/CS	5

POSITION 11 - RANGE SPRING			
Steel Range Spring		STD 15 PSID	5 PSID
psig	(Barg)	CODE	CODE
5-15	(.34-1.0)	1	A
10-40	(.69-2.8)	2	B
30-80	(2.1-5.5)	3	C
70-150	(4.8-10.3)	4	D
Option-20 Pressure Loaded		Y	-

POSITION 12 - TRIM OPTIONS		
Description	Option	CODE
No Option	---	0
For Special Construction Contact Cashco for Special Product Code.	SPQ	X

POSITION 13 - FEATURE OPTIONS		
Description	Option	CODE
No Option	-	0
Handwheel & Locking Lever.	-3	3

POSITION 16 - CERTIFICATE OPTIONS		
Description	Option	CODE
No Option	-	0
Special Cleaning: Per Cashco Spec #S-1542.	-56	N

*** For information on ATEX see pages 13 & 14 on the IOM.**

Алматы (7273)495-231
Ангарск (3955)60-70-56
Архангельск (8182)63-90-72
Астрахань (8512)99-46-04
Барнаул (3852)73-04-60
Белгород (4722)40-23-64
Благовещенск (4162)22-76-07
Брянск (4832)59-03-52
Благовосток (423)249-28-31
Владикавказ (8672)28-90-48
Владимир (4922)49-43-18
Волгоград (844)278-03-48
Волгодд (8172)26-41-59
Воронеж (473)204-51-73
Екатеринбург (343)384-55-89

Иваново (4932)77-34-06
Ижевск (3412)26-03-58
Иркутск (395)279-98-46
Казань (843)206-01-48
Калининград (4012)72-03-81
Калуга (4842)92-23-67
Кемерово (3842)65-04-62
Киров (8332)68-02-04
Коломна (4966)23-41-49
Кострома (4942)77-07-48
Краснодар (861)203-40-90
Красноярск (391)204-63-61
Курск (4712)77-13-04
Курган (3522)50-90-47
Липецк (4742)52-20-81

Магнитогорск (3519)55-03-13
Москва (495)268-04-70
Мурманск (8152)59-64-93
Набережные Челны (8552)20-53-41
Нижний Новгород (831)429-08-12
Новокузнецк (3843)20-46-81
Новосибирск (383)227-86-73
Омск (3812)21-46-40
Орел (4862)44-53-42
Оренбург (3532)37-68-04
Пенза (8412)22-31-16
Петрозаводск (8142)55-98-37
Псков (8112)59-10-37
Пермь (342)205-81-47

Ростов-на-Дону (863)308-18-15
Рязань (4912)46-61-64
Самара (846)206-03-16
Санкт-Петербург (812)309-46-40
Саратов (845)249-38-78
Севастополь (8692)22-31-93
Саранск (8342)22-96-24
Симферополь (3652)67-13-56
Смоленск (4812)29-41-54
Сочи (862)225-72-31
Ставрополь (8652)20-65-13
Сургут (3462)77-98-35
Сыктывкар (8212)25-95-17
Тамбов (4752)50-40-97
Тверь (4822)63-31-35

Тольятти (8482)63-91-07
Томск (3822)98-41-53
Тула (4872)33-79-87
Тюмень (3452)66-21-18
Ульяновск (8422)24-23-59
Улан-Удэ (3012)59-97-51
Уфа (347)229-48-12
Хабаровск (4212)92-98-04
Чебоксары (8352)28-53-07
Челябинск (351)202-03-61
Череповец (8202)49-02-64
Чита (3022)38-34-83
Якутск (4112)23-90-97
Ярославль (4852)69-52-93

Россия +7(495)268-04-70

Казахстан +7(7172)727-132

Киргизия +996(312)96-26-47

<https://cashco.nt-rt.ru/> || coc@nt-rt.ru