



ISO Registered Company

MODEL BQ

BACK PRESSURE RELIEF REGULATOR



MODEL BQ

OVERVIEW

The Model BQ is a relief regulator suitable as a back pressure regulator or bypass valve for controlling inlet pressures between 5 and 300 psig (.34 to 20.7 Barg). For 1/4", 3/8" or 1/2" (DN8, 10, and 15) process piping. Available options include cryogenic construction and differential/pressure loaded construction.

FEATURES

- Versatile:** Four body materials and twenty-one trim material combinations allow compatibility with many fluids.
- High Capacity:** A large orifice and diaphragm provide sensitivity with high capacity.
- Tight Shut Off:** A composition seat is available in several materials.

APPLICATIONS

Designed for controlling a wide range of fluids including air, inert gases, cryogenic gas or liquids, chemicals, water, fuel oil and steam. See Table 1 for more information.



LINE SIZES AVAILABLE

1/4" (DN8), 3/8" (DN10), 1/2" (DN15)



END CONNECTIONS

NPT



COMMON APPLICATIONS

AIR, INERT GASES, CRYOGENIC GAS OR LIQUIDS, CHEMICALS, WATER, FUEL OIL, STEAM



DESIGN PRESSURE

MAXIMUM INLET PRESSURE:
UP TO 400 psig (27.6 Barg)

Алматы (7273)495-231
Ангарск (3955)60-70-56
Архангельск (8182)63-90-72
Астрахань (8512)99-46-04
Барнаул (3852)73-04-60
Белгород (4722)40-23-64
Благовещенск (4162)22-76-07
Брянск (4832)59-03-52
Владивосток (423)249-28-31
Владикавказ (8672)28-90-48
Владимир (4922)49-43-18
Волгоград (844)278-03-48
Волгодда (8172)26-41-59
Воронеж (473)204-51-73
Екатеринбург (343)384-55-89

Иваново (4932)77-34-06
Ижевск (3412)26-03-58
Иркутск (395)279-98-46
Казань (843)206-01-48
Калининград (4012)72-03-81
Калуга (4842)92-23-67
Кемерово (3842)65-04-62
Киров (8332)68-02-04
Коломна (4966)23-41-49
Кострома (4942)77-07-48
Краснодар (861)203-40-90
Красноярск (391)204-63-61
Курск (4712)77-13-04
Курган (3522)50-90-47
Липецк (4742)52-20-81

Магнитогорск (3519)55-03-13
Москва (495)268-04-70
Мурманск (8152)59-64-93
Набережные Челны (8552)20-53-41
Нижний Новгород (831)429-08-12
Новокузнецк (3843)20-46-81
Ноябрьск (3496)41-32-12
Новосибирск (383)227-86-73
Омск (3812)21-46-40
Орел (4862)44-53-42
Оренбург (3532)37-68-04
Пенза (8412)22-31-16
Петрозаводск (8142)55-98-37
Псков (8112)59-10-37
Пермь (342)205-81-47

Ростов-на-Дону (863)308-18-15
Рязань (4912)46-61-64
Самара (846)206-03-16
Санкт-Петербург (812)309-46-40
Саратов (845)249-38-78
Севастополь (8692)22-31-93
Саранск (8342)22-96-24
Симферополь (3652)67-13-56
Смоленск (4812)29-41-54
Сочи (862)225-72-31
Ставрополь (8652)20-65-13
Сургут (3462)77-98-35
Сыктывкар (8212)25-95-17
Тамбов (4752)50-40-97
Тверь (4822)63-31-35

Тольятти (8482)63-91-07
Томск (3822)98-41-53
Тула (4872)33-79-87
Тюмень (3452)66-21-18
Ульяновск (8422)24-23-59
Улан-Удэ (3012)59-97-51
Уфа (347)229-48-12
Хабаровск (4212)92-98-04
Чебоксары (8352)28-53-07
Челябинск (351)202-03-61
Череповец (8202)49-02-64
Чита (3022)38-34-83
Якутск (4112)23-90-97
Ярославль (4852)69-52-93

Россия +7(495)268-04-70

Казахстан +7(7172)727-132

Киргизия +996(312)96-26-47

STANDARD/GENERAL SPECIFICATIONS

- Body Sizes:** 1/4", 3/8" or 1/2" (DN8, 10, or 15) inlet and flow-thru connections. 1/2" (DN15) outlet bottom connection. NPT female only.
- Body/Spring Chamber Material Combinations:** DI = Ductile iron
CS = Cast carbon steel
BRZ = Cast bronze
SST = Cast stainless steel
See Table 2 for material specifications.
- Inlet Pressure:** Up to 400 psig (27.6 Barg). (Includes 100 psi (6.9 Barg) pressure build when set at 300 psig (20.7 Barg) under low flow rate.) See Table 2.
- Operating Temperature:** See Tables 2, 3, and 4.
- Trim Design:** Metal seated or composition seated brass or SST materials. See Figures 1 and 2, and Tables 3 and 4.
- Capacities:** Up to 2 C_v; see Table 5 for C_v vs. set pressure.
Water Flow - see Table 6.
Compressed Air Flow - see Table 7.

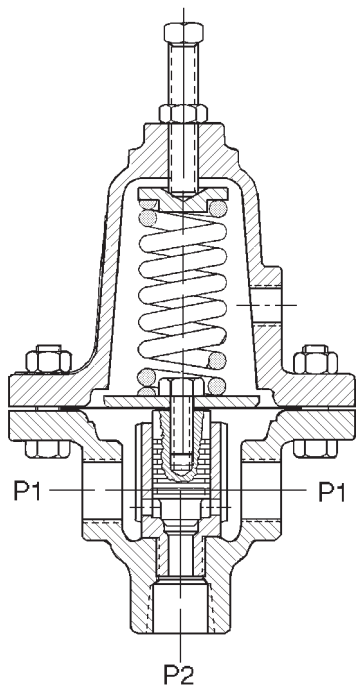

Figure 1: Standard Metal Seat Design

- Cont'd** Tables show capacities of 10, 20, 30, 40 and 50% build-up over the set pressure. Set pressures were determined using a flow rate of 2% or less of the 20% build-up capacities. Example: 100 psig (6.89 Barg) set pressure and a 20% build-up = 120 psig (8.27 Barg) flowing pressure for the capacity listed.
- Diaphragm:** Phosphor Bronze, Neoprene (BC), Fluorocarbon Elastomer (FKM) EPDM, SST TFE coated SST, Elgiloy.
- Gasket:** Standard: Graphite/NBR. **NOT SUITABLE FOR OXYGEN SERVICE.**
Alternate Material: See Opt-45.
- Range Springs:** Standard: Epoxy Coated Steel.
Cryogenic: SST.

STANDARD		CRYOGENIC	
STEEL RANGE SPRINGS		SST RANGE SPRINGS	
psig	(Barg)	psig	(Barg)
5 - 15	(0.34 - 1.03)	5 - 15	(0.34 - 1.03)
10 - 25	(0.69 - 1.72)	10 - 25	(0.69 - 1.72)
20 - 75	(1.38 - 5.17)	20 - 75	(1.38 - 5.17)
65 - 150	(4.48 - 10.3)	65 - 150	(4.48 - 10.3)
140 - 300	(9.65 - 20.68)	140 - 210	(9.65 - 14.48)

- Flange Bolting:** Standard: Zinc plated; heat treated steel.
Cryogenic: SST.
- Painting:** Standard: All non-corrosion resistant portions to be painted with corrosion resistant epoxy paint per Cashco Spec #S-1606.

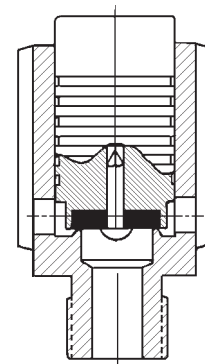

Figure 2: Composition Seat Design

OPTION SPECIFICATIONS

OPTION -1: CLOSING CAP. A removable cast iron cap discourages tampering with spring setting. Available only with DI or SST spring chamber materials. Includes a 1/4" (DN8) NPT female vent connection.

OPTION -1+6: DIFFERENTIAL CONSTRUCTION. For differential or pressure loaded service; includes features of Opt-1 plus a gasket for sealing the closing cap to the spring chamber, a thread seal for the lock nut, a pusher plate and a top-side diaphragm gasket (metal diaphragms only).

The pressure loading, plus the spring setting, plus build-up to stroke the plug must not exceed pressures listed Table 2.



CAUTION

Option-1+6 contains single diaphragm construction. In the event of diaphragm failure, the process fluid will mix with the loading fluid. Please alert your representative so an alternative product can be selected.

OPTION -5: BRASS/BRONZE CRYOGENIC CONSTRUCTION. BRZ/BRZ Body/spring chamber materials only. Brass adjusting screw, locknut, pressure plate and spring button. SST range spring and flange bolting. Only B0 and B5 trim selections allowed. Cleaned and packaged for oxygen service per Cashco Spec. #S-1134. Spring chamber has 1/4" NPT female connection for purge gas plus a 1/8" drilled drain hole. Mount in horizontal piping with the adjusting screw oriented downwards. Applicable temperature range -325°F to +150°F (-198°C to +66°C)

OPTION -25: VENT TAP. Spring chamber vent tapped 1/4" (DN8) NPT female for remote venting.

OPTION -25S: VENT SCREEN. Cap. (For Opt-25)

OPTION -36: SST CRYOGENIC CONSTRUCTION. Same specifications as Opt-5 except:

- a. For SST/SST body/spring chamber materials.
- b. S1 and S36 only available trim selections.

OPTION -45: TFE GASKETS. Primarily for oxygen service. Temperature range: -20° to +400°F (-29° to +205°C).

OPTION -55: SPECIAL CLEANING. BRZ or SST body materials only. Cleaned per Cashco Spec. #S-1134 for oxygen service. **NOTE:** Design Pressure Rating shall not exceed 375 psig (25.8 Barg) when body material is SST and process medium is oxygen.

OPTION -56: SPECIAL CLEANING. DI, CS, or SST body materials only. Cleaned per Cashco Spec. #S-1542. Not suitable for oxygen service.

TECHNICAL SPECIFICATIONS

**TABLE 1
APPLICATIONS**

FLUID	RECOMMENDED CONSTRUCTION	TRIM DESIGNATION NUMBER
Air or Inert Gases	Composition Seat and Diaphragm	B2 , B3 or BB
Chemical	Metal Seat and Diaphragm	S0,S1, or S40M
	Metal Seat and Composition Diaphragm	S5 or S40
	Composition Seat and Metal Diaphragm	S9 or S36
	Composition Seat and Diaphragm	S3, S40T, SB, or S40V
Cryogenic Gas or Liquids	TFE Seat and Metal Diaphragm	B5 or S36
	Metal Seat and Diaphragm	B0 or S1
Fuel Oil	Composition Seat and Diaphragm	BB, B4, BK, S3 or SB
Hydrocarbon Gas or Liquids	Composition Seat and Diaphragm	BB, B4, BK, S3, S3N or SB
Steam, All Pressures, Saturated or Super-heated	Metal Seat and Diaphragm	B0 or S1
Water and Condensate Low Temperature 32-180°F (0-83°C)	Composition Seat and Diaphragm	BB, B2 , B3, S3, S3N or SB
Water and Condensate High Temperature 180-300°F (83-149°C)	Composition Seat and Diaphragm	B6
	Metal Seat and Diaphragm	B0 or S1
NOTE: Trim Designation Nos. in "boldface" are the most commonly used. Cashco, or its representatives may make recommendations or suggestions as to the suitability of certain trims for specific services. These are trims that have been used successfully in the past in similar applications. However, the user has final responsibility for materials selected.		

**TABLE 2
BODY AND SPRING CHAMBER
MAXIMUM PRESSURE WITH TEMPERATURE RATINGS**

MATERIAL SPECIFICATIONS (Body / Spring Chamber)		INLET			
Description (Abbr.)	ASTM No.	Pressure		Temperature	
		Psig	(Barg)	°F	°C
DI/DI	A395	400	(27.6)	-20 to +275	(-29 to +135)
		300	(20.7)	+400	(+205)
		250	(17.2)	+450	(+232)
BRZ/DI	B62 Alloy C83600/ A395	400	(27.6)	-20 to +150	(-29 to +66)
		300	(20.7)	+350	(+177)
BRZ/BRZ ¹	B62, Alloy C83600	250	(17.2)	+400	(+205)
CS/SST	A216, Gr. WCB/ A351, Gr. CF8M	400	(27.6)	-20 to +600	(-29 to +315)
SST/SST	A351, Gr. CF8M				
NOTE 1: For operating temperatures between -325 to +150F (-198 to +66°C), specify Opt-5 with trim B0 or B5, or Opt-36 with trim S1 or S36.					

**TABLE 3
BRASS TRIM MATERIAL COMBINATIONS**

PART	BRASS TRIM DESIGNATION NUMBER								
	BO*	B1	B2	B3	B4	B5*	B6	BB	BK
Cylinder	Brass	Brass	Brass	Brass	Brass	Brass	Brass	Brass	Brass
Piston	Brass	Brass	Brass	Brass	Brass	Brass	Brass	Brass	Brass
Seat Disc	None (Metal)	None (Metal)	NBR	TFE	TFE	TFE	EPR	NBR	FKM
Pin	None	None	Brass	Brass	Brass	Brass	Brass	Brass	Brass
Diaphragm	Phos. Brz.	302 SST	BC	BC	FKM	Phos. Brz.	EPDM	NBR	FKM
Temperature Range °F (°C)	-20 to +200	-20 to +400	-20 to +180	-20 to +180	-20 to +400	-20 to +200	-20 to +300	-20 to +180	-20 to +400
	(-29 to +94)	(-29 to +205)	(-29 to +83)	(-29 to +83)	(-29 to +205)	(-29 to +93)	(-29 to +149)	(-29 to +83)	(-29 to +205)

* For operating temperatures between -325 to +150F (-198 to +66°C), specify Opt-5 and trim B0 or B5.

**TABLE 4
STAINLESS STEEL TRIM MATERIAL COMBINATIONS**

PART	STAINLESS STEEL TRIM DESIGNATION NUMBER											
	SO	S1*	S3	S3N	S5	S9	S36*	S40	S40M	S40T	S40V	SB
Cylinder	316 SST	316 SST	316 SST	316 SST	316 SST	316 SST	316 SST	316 SST	316 SST	316 SST	316 SST	316 SST
Piston	316 SST	316 SST	316 SST	316 SST	316 SST	316 SST	316 SST	316 SST	316 SST	316 SST	316 SST	316 SST
Seat Disc	None (Metal)	None (Metal)	TFE	NBR	None (Metal)	TFE	TFE	None (Metal)	None (Metal)	TFE	FKM	NBR
Pin	None	None	316 SST	316 SST	None	316	316	None	None	316 SST	316 SST	316 SST
Diaphragm	TFE coated 302 SST	302 SST	BC	BC	FKM	TFE coated 302 SST	302 SST	BC	Elgiloy	FKM	FKM	NBR
Temperature Range °F (°C)	-20 to +400		-20 to +180		-20 to +400			-20 to +180	-20 to +400		-20 to +400	-20 to +180
	(-29 to +205)		(-29 to +83)		(-29 to +205)			(-29 to +83)	(-29 to +205)		(-29 to +205)	(-29 to +83)

* For operating temperatures between -325 to +100F (-198 to +38°C), specify Opt-36 and trim S1 or S36.

ABBREVIATIONS
 NBR = Buna-N BC = Neoprene EPR = Ethylene Propylene EPDM = Ethylene Propylene Diene TFE = Polytetrafluoroethylene
 FK = Fluorosilicone FKM = Fluorocarbon elastomer TFE = Polytetrafluoroethylene Phos BRZ = Phosphor Bronze

**TABLE 5
C_v FOR SET PRESSURES PLUS PRESSURE BUILD
(F_L = 0.945)**

SETPPOINT PRESSURE psig	METAL DIAPHRAGM					COMPOSITION DIAPHRAGM				
	PRESSURE BUILD-UP OVER SET PRESSURE					PRESSURE BUILD-UP OVER SET PRESSURE				
	10%	20%	30%	40%	50%	10%	20%	30%	40%	50%
5	0.45	0.49	0.58	0.64	0.70	0.98	1.81	2.00	2.00	2.00
10	0.46	0.50	0.60	0.71	0.75	1.20	1.94	2.00	2.00	2.00
15	0.47	0.57	0.64	0.77	0.90	1.43	2.00	2.00	2.00	2.00
25	0.45	0.63	0.85	1.03	1.23	1.43	2.00	2.00	2.00	2.00
35	0.47	0.57	0.64	0.77	0.90	0.71	1.41	1.86	2.00	2.00
50	0.48	0.58	0.75	0.90	1.08	0.98	1.79	2.00	2.00	2.00
75	0.50	0.70	0.92	1.20	1.40	1.43	2.00	2.00	2.00	2.00
100	0.50	0.68	0.90	1.15	1.36	1.13	1.79	2.00	2.00	2.00
150	0.52	0.95	1.43	1.73	1.81	1.43	2.00	2.00	2.00	2.00
200	0.50	0.70	0.92	1.20	1.40	0.45	0.98	1.46	1.80	1.95
300	0.52	0.95	1.43	1.73	1.81	0.75	1.50	1.91	NR	NR

TABLE 6
WATER CAPACITY IN GPM
S.G. = 1.0 T = 60° F_L = 0.945
All Sizes - Composition Diaphragm Only

OUTLET PRESSURE (psig)	SETPOINT PRESSURE (psig)	ALL BODY SIZES				
		% BUILD				
		10%	20%	30%	40%	50%
ATM	5	2.3	4.4	5.1	5.3	5.5
	10	4	6.7	7.2	7.5	7.8
	15	5.8	8.5	8.8	9.2	9.5
	25	7.5	HI VEL	HI VEL	CAV	CAV
	30	4.4	9.1	CAV	CAV	CAV
	50	7.3	CAV	CAV	CAV	CAV
	75	HI VEL	HI VEL	HI VEL	HI VEL	HI VEL
	100	HI VEL	HI VEL	HI VEL	HI VEL	HI VEL
	150	HI VEL	HI VEL	HI VEL	HI VEL	HI VEL
	200	6.7	HI VEL	HI VEL	HI VEL	HI VEL
	300	HI VEL	HI VEL	HI VEL	HI P1	HI P1
5	10	2.9	5.1	5.7	6.0	6.3
	15	4.9	7.2	7.6	8.0	8.4
	25	6.8	10	10.5	HI VEL	HI VEL
	35	4.1	8.6	HI VEL	CAV	CAV
	50	6.9	HI VEL	CAV	CAV	CAV
	75	HI VEL	HI VEL	7410	HI VEL	HI VEL
	100	HI VEL	HI VEL	HI VEL	HI VEL	HI VEL
	150	HI VEL	HI VEL	HI VEL	HI VEL	HI VEL
	200	6.6	HI VEL	HI VEL	HI VEL	HI VEL
	300	HI VEL	HI VEL	HI VEL	HI P1	HI P1
10	15	3.7	5.7	6.2	6.6	7.1
	25	6.0	8.9	9.5	10.0	10.5
	35	3.8	8.0	HI VEL	HI VEL	HI VEL
	50	6.6	HI VEL	HI VEL	CAV	CAV
	75	HI VEL	HI VEL	HI VEL	HI VEL	HI VEL
	100	HI VEL	HI VEL	HI VEL	HI VEL	HI VEL
	150	HI VEL	HI VEL	HI VEL	HI VEL	HI VEL
	300	HI VEL	HI VEL	HI VEL	HI P1	HI P1
15	25	5.1	7.8	8.4	8.9	9.5
	35	3.4	7.3	10.3	HI VEL	HI VEL
	50	6.2	HI VEL	HI VEL	HI VEL	CAV
	75	HI VEL	HI VEL	HI VEL	HI VEL	HI VEL
	100	HI VEL	HI VEL	HI VEL	HI VEL	HI VEL
	150	HI VEL	HI VEL	HI VEL	HI VEL	HI VEL
	200	6.4	HI VEL	HI VEL	HI VEL	HI VEL
	300	HI VEL	HI VEL	HI VEL	HI P1	HI P1
25	35	2.6	5.8	8.4	9.8	10.5
	50	5.4	10.6	HI VEL	HI VEL	HI VEL
	75	10.8	HI VEL	HI VEL	CAV	CAV
	100	10.4	HI VEL	CAV	CAV	CAV
	150	HI VEL	HI VEL	HI VEL	HI VEL	HI VEL
	200	6.3	HI VEL	HI VEL	HI VEL	HI VEL
	300	HI VEL	HI VEL	HI VEL	HI P1	HI P1

NOTE: Where "HI P1" is indicated, the pressure build exceeds established limits in Technical Bulletin.
Where "CAV" is indicated, the flow has reached choked flow, full cavitation.

TABLE 7
AIR CAPACITY - SCFH
S.G. = 1.0 T = 60° F_L = 0.945
All Sizes - Composition Diaphragm Only

OUTLET PRESSURE (psig)	SETPOINT PRESSURE (psig)	ALL BODY SIZES				
		% BUILD				
		10%	20%	30%	40%	50%
ATM	5	650	1240	1400	1430	1470
	10	1020	1710	1830	1890	1960
	15	1360	2160	2260	2360	2460
	25	1990	2950	3120	3280	3450
	30	1120	2360	3300	3740	3940
	50	2250	4410	5260	5590	5920
	75	4590	4410	5260	5590	5920
	100	4650	4410	5260	5590	5920
	150	4650	4410	5260	5590	5920
	200	3490	4410	5260	5590	5920
300	3490	4410	5260	HI P1	HI P1	
5	10	990	1660	1770	1840	1900
	15	1360	2160	2260	2360	2450
	25	1990	2950	3120	3280	3450
	30	1120	2360	3300	3740	3940
	50	2250	4410	5260	5590	5920
	75	4590	6910	7410	7900	8400
	100	4650	7960	7410	7900	8400
	150	8480	7960	7410	7900	8400
	200	3490	8240	7410	7900	8400
300	8530	8240	7410	HI P1	HI P1	
10	15	1190	1890	1980	2060	2150
	25	1980	2930	3100	3260	3420
	30	1120	2360	3300	3740	3940
	50	2250	4410	5260	5590	5920
	75	4590	6910	7410	7900	8400
	100	4650	7960	9550	10210	10870
	150	8480	7960	9550	10210	10870
	200	3490	8240	9550	10210	10870
300	8530	8240	9550	HI P1	HI P1	
15	25	1840	2720	2870	3020	3180
	30	1080	2290	3190	3630	3820
	50	2250	4410	5260	5590	5920
	75	4590	6910	7410	7900	8400
	100	4650	7960	9550	10210	10870
	150	8480	12850	9550	10210	10870
	200	3490	8240	9550	10210	10870
	300	8530	8240	9550	HI P1	HI P1
25	30	760	1600	2240	2540	2670
	50	2180	4280	5100	5420	5740
	75	4590	6910	7400	7900	8390
	100	4650	7960	9550	10210	10870
	150	8480	12850	13840	14830	15820
	200	3490	8240	13240	17510	15820
	300	8530	8240	13240	HI P1	HI P1

NOTE: Where "HI P1" is indicated, the pressure build exceeds established limits in Technical Bulletin.

DIMENSIONS AND WEIGHTS

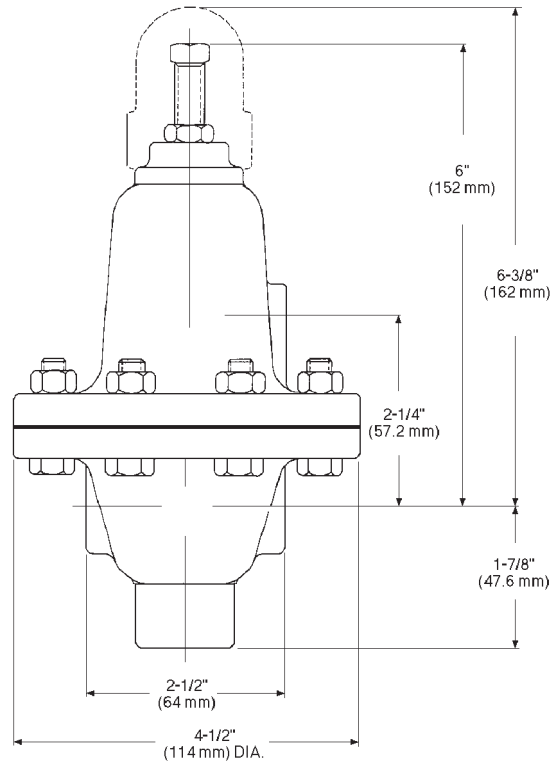

Shipping Weight All Sizes	Lbs.	Kg.
	8	4

The contents of this publication are presented for informational purposes only, and while every effort has been made to ensure their accuracy, they are not to be construed as warranties or guarantees, express or implied, regarding the products or services described herein or their use or applicability. We reserve the right to modify or improve the designs or specifications of such product at any time without notice. Cashco, Inc. does not assume responsibility for the selection, use or maintenance of any product. Responsibility for proper selection, use and maintenance of any Cashco, Inc. product remains solely with the purchaser.

MODEL BQ PRODUCT CODER 02/07/20

An "X" in POS 12 followed by a 5-digit control number overrides remaining selections.



POSITION 2 - GASKET * & SERVICE				
Service	Gaskets	Options	CODE	
Basic (Above -20°F(-29°C))	Non-Oxygen	Std: Graphite / NBR	—	B
	Primarily for Oxygen	TFE	-45	D
Cryogenic -325 to +100°F (-198 to 38°C)	All	TFE	-5 & -36**	C

* Refer to Tech Bulletin for temperature limits.
** Cryo Const. includes Special Cleaning #S-1134 (Opt.-55).

POSITION 3 - SIZE				
Size				CODE
Inlet		Outlet		
1/4"	DN8	1/2"	DN15	2
3/8"	DN10	1/2"	DN15	3
1/2"	DN15	1/2"	DN15	4

POSITION 5 - BODY & SP. CHAMBER MATERIALS	
Body/Sp. Ch.	CODE
DI/DI	1
BRZ/DI	2
BRZ/BRZ*	3
CS/SST	6
SST/SST **	A

* Utilize w/cryo Opt-5
** Utilize w/cryo Opt-36

POSITION 6 & 7 - TRIM DESIGNATION NUMBERS							
Brass Trim				Stainless Steel Trim			
Desig.	Body Material			Desig.	Body Material		
	BRZ CODE	DI CODE	CS CODE		DI CODE	CS CODE	SST CODE
B0*	B0	B0	B0	S0	S0	S0	S0
B1	B1	B1	B1	S1**	S1	S1	S1
B2	B2	B2	B2	S3	S3	S3	S3
B3	B3	B3	—	S3N	SC	SC	SC
B4	B4	B4	—	S5	S5	S5	S5
B5*	B5	B5	—	S9	S9	S9	S9
B6	B6	B6	—	S36 **	36	36	36
BB	BB	BB	BB	S40	40	40	40
BK	BK	BK	BK	S40V	—	4V	4V
				S40M	—	4M	4M
				S40T	—	4T	4T
				SB	SB	SB	SB

* Trim utilized w/cryo Opt-5
** Trim utilized w/cryo Opt-36

POSITION 11 - RANGE SPRING					
Standard			Cryogenic (OPT-5 & -36)		
Steel Range Spring		CODE	SST Range Spring		CODE
psig	Barg		psig	(Barg)	
5-15	(.34-1.03)	1	5-15	(.34-1.03)	A
10-25	(.69-1.72)	2	10-25	(.69-1.72)	B
20-75	(1.38-5.17)	3	20-75	(1.38-5.17)	C
65-150	(4.48-10.3)	4	65-150	(4.48-10.3)	D
140-300	(9.65-20.68)	5	140-210	(9.65-14.48)	F

POSITION 12 - TRIM OPTIONS		
Description	Option	CODE
No Option	—	0
For Special Construction Contact Cashco for Special Product Code	SPQ	X

POSITION 14 - SPRING CHAMBER OPTIONS			
Description	Option	CODE	
No Option	—	0	
1/4" NPT Vent Tap.	-25	E	
SST Rain-proof Bug Vent (Includes Opt-25).	-25S	H	

POSITION 13 - FEATURE OPTIONS		
Description	Option	CODE
No Option	—	0
DI Closing Cap DI or SST Spring Chamber. (Included with Opt-1+6 Variation). (Includes Opt-25)	-1	1
Differential Const. w/Closing Cap on DI or SST Spring Chamber	-1+6	8

POSITION 16 - CERTIFICATE OPTIONS			
Description	Option	CODE	
No Option	—	0	
Special Cleaning: Per Cashco Spec #S-1134. BRZ or SST body/sp.ch. mat'ls only. Suitable for oxygen service. (Not Available w/ "1+6" Variation).	-55	M	
Special Cleaning: Per Cashco Spec #S-1542.	-56	N	

*** For information on ATEX see pages 8 & 9 on the IOM.**

Алматы (7273)495-231
Ангарск (3955)60-70-56
Архангельск (8182)63-90-72
Астрахань (8512)99-46-04
Барнаул (3852)73-04-60
Белгород (4722)40-23-64
Благовещенск (4162)22-76-07
Брянск (4832)59-03-52
Владивосток (423)249-28-31
Владикавказ (8672)28-90-48
Владимир (4922)49-43-18
Волгоград (844)278-03-48
Волгодар (8172)26-41-59
Воронеж (473)204-51-73
Екатеринбург (343)384-55-89

Иваново (4932)77-34-06
Ижевск (3412)26-03-58
Иркутск (395)279-98-46
Казань (843)206-01-48
Калининград (4012)72-03-81
Калуга (4842)92-23-67
Кемерово (3842)65-04-62
Киров (8332)68-02-04
Коломна (4966)23-41-49
Кострома (4942)77-07-48
Краснодар (861)203-40-90
Красноярск (391)204-63-61
Курск (4712)77-13-04
Курган (3522)50-90-47
Липецк (4742)52-20-81

Магнитогорск (3519)55-03-13
Москва (495)268-04-70
Мурманск (8152)59-64-93
Набережные Челны (8552)20-53-41
Нижний Новгород (831)429-08-12
Новокузнецк (3843)20-46-81
Новоябрьск (3496)41-32-12
Новосибирск (383)227-86-73
Омск (3812)21-46-40
Орел (4862)44-53-42
Оренбург (3532)37-68-04
Пенза (8412)22-31-16
Петрозаводск (8142)55-98-37
Псков (8112)59-10-37
Пермь (342)205-81-47

Ростов-на-Дону (863)308-18-15
Рязань (4912)46-61-64
Самара (846)206-03-16
Санкт-Петербург (812)309-46-40
Саратов (845)249-38-78
Севастополь (8692)22-31-93
Саранск (8342)22-96-24
Симферополь (3652)67-13-56
Смоленск (4812)29-41-54
Сочи (862)225-72-31
Ставрополь (8652)20-65-13
Сургут (3462)77-98-35
Сыктывкар (8212)25-95-17
Тамбов (4752)50-40-97
Тверь (4822)63-31-35

Тольятти (8482)63-91-07
Томск (3822)98-41-53
Тула (4872)33-79-87
Тюмень (3452)66-21-18
Ульяновск (8422)24-23-59
Улан-Удэ (3012)59-97-51
Уфа (347)229-48-12
Хабаровск (4212)92-98-04
Чебоксары (8352)28-53-07
Челябинск (351)202-03-61
Череповец (8202)49-02-64
Чита (3022)38-34-83
Якутск (4112)23-90-97
Ярославль (4852)69-52-93

Россия +7(495)268-04-70

Казахстан +7(7172)727-132

Киргизия +996(312)96-26-47